

IMPORTANT NOTICE

THE VEHICLE IS DESIGNED AND MANUFACTURED FOR OFF-ROAD USE ONLY. IT IS ILLEGAL TO OPERATE THIS VEHICLE ON ANY PUBLIC STREET, ROAD OR HIGHWAY, SUCH AS IS PROHIBITED BY LAW. THIS VEHICLE COMPLIES WITH ALL STATE OFF-HIGHWAY ENGINE EMISSION AND SPARK PLUG LAWS AND REGULATIONS. PLEASE CHECK YOUR LOCAL LAWS AND REGULATIONS BEFORE OPERATING THIS VEHICLE. WHEN YOU RIDE THE MACHINE, YOU MUST KNOW THE FOLLOWING REQUIREMENTS FOR YOUR SAFETY.

SAFETY WARNINGS

- 1. Riding on paved surfaces should be avoided. It can cause a loss of control. If you must ride on a paved surface, the slowest and most careful riding technique should be used.
- 2. GASOLINE IS HIGHLY FLAMMABLE.
 - * Always run off the engine when refueling.
 - * Take care not to spill gasoline on the engine or exhaust pipe muffler when refueling.
 - * Never refuel when the engine is hot or the spark plug is hot.
- 3. If you should experience engine problems or a lot of gasoline vapor or slow engine operation, pull in your clutch and stop the engine immediately. If any gasoline leaks or you are in danger, immediately wash it with water and soap, and change your clothes. A way to stop the engine before the spark plug ignites the mixture is to pull in the clutch.
- 4. When riding the machine, wear the following:
 - * The engine and exhaust pipe muffler may be hot. Do not touch the engine or muffler when the machine is running.
 - * Do not touch the muffler, exhaust pipe or engine when the machine is running.

YTZ250N
OWNER'S MANUAL AND SERVICE
©1984 by Yamaha Motor Corporation, U.S.A.
1st Edition, April 1984
All rights reserved. Any reprinting or unauthorized use without the written permission of Yamaha Motor Corporation, U.S.A. is expressly prohibited.
Printed in Japan
P/N LIT-11626-04-40

IMPORTANT NOTICE

THIS VEHICLE IS DESIGNED AND MANUFACTURED FOR OFF-ROAD USE ONLY. IT IS ILLEGAL TO OPERATE THIS VEHICLE ON ANY PUBLIC STREET, ROAD OR HIGHWAY. SUCH USE IS PROHIBITED BY LAW. THIS VEHICLE COMPLIES WITH ALMOST ALL STATE OFF-HIGHWAY NOISE LEVEL AND SPARK ARRESTER LAWS AND REGULATIONS. PLEASE CHECK YOUR LOCAL RIDING LAWS AND REGULATIONS BEFORE OPERATING THIS VEHICLE. WHEN YOU RIDE THE MACHINE, YOU MUST KNOW THE FOLLOWING REQUIREMENTS FOR YOUR SAFETY.

SAFETY WARNINGS:

1. Riding on paved surfaces should be avoided; it can seriously affect handling. If necessary, ride slowly and don't take sudden turns.
2. **GASOLINE IS HIGHLY FLAMMABLE:**
 - * Always turn off the engine when refueling.
 - * Take care not to spill gasoline on the engine or exhaust pipe/muffler, when refueling.
 - * Never refuel while smoking or in the vicinity of an open flame.
3. If you should swallow some gasoline or inhale a lot of gasoline vapor, or allow some gasoline to get in your eye(s), see your doctor immediately. If any gasoline spills on your skin or clothing, immediately wash it with soap and water, and change your clothes.
4. Always turn off the engine before leaving the machine unattended. When parking the machine, note the following:
 - * The engine and exhaust pipe(s)/muffler(s) may be hot. Park the machine in a place where pedestrians or children are not likely to touch the machine.
 - * Do not park the machine on a slope or soft ground; the machine may overturn.
 - * Park on level ground with engine at a stop and in first gear.
5. When transporting the machine in another vehicle, be sure it is kept upright and that the fuel cock is turned to the "OFF". If it should lean over, gasoline may leak out of the carburetor or fuel tank.
6. Never start your engine or let it run for any length of time in a closed area. The exhaust fumes are poisonous and may cause loss of consciousness and death within a short time. Always operate your machine in an area with adequate ventilation.
7. Always wear a helmet, gloves, boots, trousers, and jacket for riding.

8. When crossing especially a desert area, be sure to put a caution flag on the specified location of the machine for collision protection. Don't use the flag pole bracket as a trailer hitch.
9. Do not allow your feet to stretch out your legs or allow your feet to slide over ground surfaces when you start off or during operation. Put your feet on the footrests.
10. This is a highly powerful vehicle and should only be ridden by an experienced (/skillful) rider.
This machine could be dangerous for a novice.
11. To avoid a burn, don't touch the exhaust system during and immediately after operation because it is very hot. Put appropriate wear, especially on your legs.
12. Most areas require the use of the spark arrester(s) and muffler(s). Don't modify the exhaust system.
13. Don't ride on private property, or in posted and "no trespassing" areas without getting permission.
14. To avoid disaster, ride cautiously on unfamiliar terrain as you may encounter hidden obstacles such as rocks, holes or ravines.
Safe riding comes from the proper judgement of your riding skill.
15. Be extra careful when starting, riding, turning and stopping the machine with additional load; e.g., accessories, cargo, a trailer, etc. Ride slowly (15 mph or less); otherwise, an accident may result.
16. This machine is designed for use as a three-wheeled vehicle capable of carrying a rider only (no passenger). The total weight of the rider, accessories, and cargo must not exceed the maximum load limit.

TO THE NEW OWNER

This manual will provide you with a good basic understanding of features, operation, and basic maintenance and inspection items of this vehicle.

PLEASE READ THIS MANUAL CAREFULLY AND COMPLETELY BEFORE OPERATING YOUR NEW MACHINE. If you have any questions regarding the operation or maintenance of your machine, please consult your Yamaha dealer.

Particularly important information is distinguished in this manual by the following notations:

NOTE: A NOTE provides key information to make procedures easier or cleaner.

CAUTION: A CAUTION indicates special procedures that must be followed to avoid damage to the machine.

WARNING: A WARNING indicates special procedures that must be followed to avoid injury to a machine operator or person inspecting or repairing the machine.

NOTICE

Some data in this manual may become outdated due to improvements made to this model in the future. If there is any question you have regarding this manual or your machine, please consult your Yamaha dealer.

Tune up kit is available for this machine, please consult your Yamaha dealer.

OVERSEAS SERVICE
OVERSEAS OPERATIONS
YAMAHA MOTOR CO., LTD.

INDEX

GENERAL INFORMATION

1

**REGULAR MAINTENANCE
AND ADJUSTMENTS**

2

**ENGINE MAINTENANCE AND
REPAIR**

3

**CHASSIS MAINTENANCE
AND REPAIR**

4

**ELECTRICAL
TROUBLESHOOTING**

5

APPENDICES

6

TABLE OF CONTENTS

1 GENERAL INFORMATION

MACHINE IDENTIFICATION	1-1
CONTROL FUNCTIONS	1-2
FUEL, OIL AND COOLANT	1-4
RIDING AND PARKING	1-6
PREOPERATION CHECKS	1-9
STARTING AND BREAK-IN	1-10
CLEANING AND STORAGE	1-12

2 REGULAR MAINTENANCE AND ADJUSTMENT

MAINTENANCE INTERVALS	2-1
LUBRICATION	2-3
SPECIAL TOOLS	2-5
MINOR MAINTENANCE AND ADJUSTMENTS	2-6

3 ENGINE MAINTENANCE AND REPAIR

PREPARATION FOR SERVICE	3-1
CARBURETOR	3-2
REED VALVE	3-9
EXHAUST PIPE AND MUFFLER	3-10
CYLINDER HEAD	3-11
CYLINDER	3-13
PISTON	3-14
CRANKCASE COVER	3-17
WATER PUMP	3-18
KICK STARTER	3-19
CLUTCH	3-21
SHIFTER	3-25
ENGINE REMOVAL	3-26
ENGINE MOUNTING	3-27
CRANKCASE	3-27
TRANSMISSION AND SHIFTER	3-29
CRANKSHAFT	3-31
COOLING SYSTEM	3-33

4 CHASSIS MAINTENANCE AND REPAIR

FRONT WHEEL	4-1
REAR WHEEL	4-2
FRONT BRAKE	4-3
REAR BRAKE	4-7
FRONT FORK	4-9
STEERING HEAD	4-17
REAR SHOCK (MONOCROSS SUSPENSION "DE CARBON" SYSTEM)	4-21
SWINGARM	4-25
DRIVE CHAIN	4-29

5 ELECTRICAL TROUBLESHOOTING

WIRING DIAGRAM	5-2
IGNITION SYSTEM	5-3
LIGHTING SYSTEM	5-7
SIGNAL SYSTEM	5-11

6 APPENDICES

TROUBLESHOOTING GUIDE	6-1
SPECIFICATIONS	6-6
GENERAL TORQUE SPECIFICATION	6-16
DEFINITION OF UNITS	6-17
CONVERSION TABLES	6-17
CABLE ROUTING	6-18
WARRANTY INFORMATION	6-22
NOISE REGULATION	6-23
MAINTENANCE RECORD	6-23

1 GENERAL INFORMATION

MACHINE IDENTIFICATION	1-1
Vehicle Identification Number.....	1-1
Engine Serial Number.....	1-1
CONTROL FUNCTIONS	1-2
FUEL, OIL AND COOLANT	1-4
Fuel	1-4
Engine Mixing Oil.....	1-4
Transmission Oil.....	1-4
Coolant Level	1-5
Coolant Draining.....	1-5
Replenishing Coolant.....	1-6
RIDING AND PARKING	1-6
Riding	1-6
Parking	1-9
PREOPERATION CHECKS	1-9
STARTING AND BREAK-IN	1-10
Starting a Cold Engine.....	1-10
Starting a Warm Engine.....	1-10
Break-in Procedures	1-11
CLEANING AND STORAGE	1-12
Cleaning	1-12
Storage	1-12

1 GENERAL INFORMATION

MACHINE IDENTIFICATION

There are two significant reasons for knowing the serial number of your machine:

1. When ordering parts, you can give the number to your Yamaha dealer for positive identification of the model you own;
2. If your machine is stolen, the authorities will need the number to search for and identify your machine.

Vehicle Identification Number

The vehicle identification number is stamped on the right of the steering head pipe.

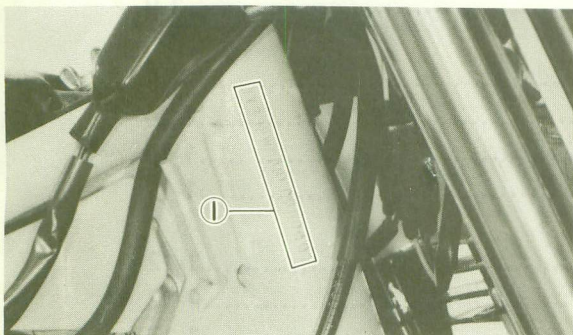

1. Vehicle identification number

Engine Serial Number

The engine serial number is stamped into the elevated part of the right rear section of the engine.

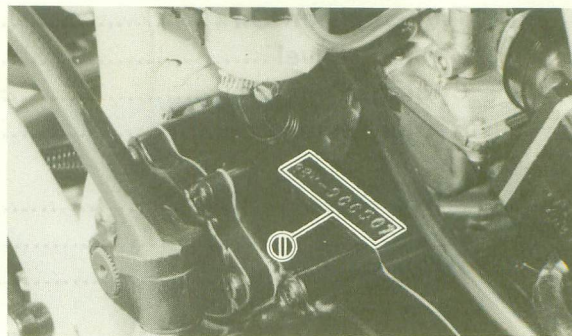

1. Engine serial number

CONTROL FUNCTIONS

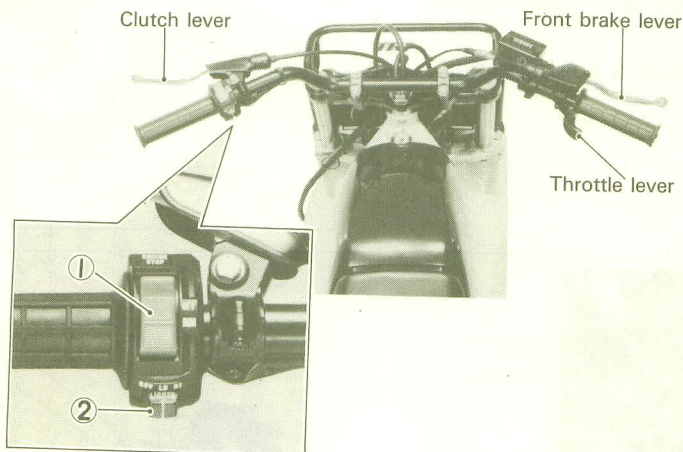

- ① Engine stop switch
- ② Light/Dimmer switch

NOTE:

The design and specification of the machine you have purchased may partly differ from those shown in the photos this manual carries.

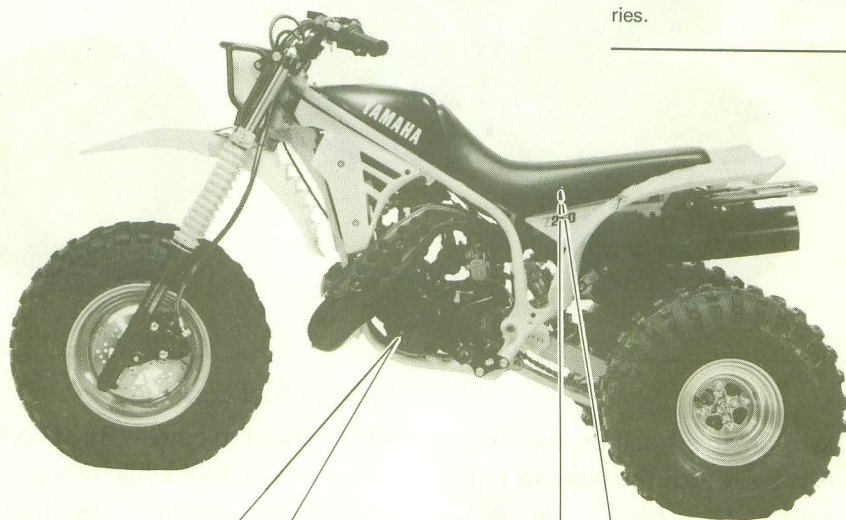

Shift pedal

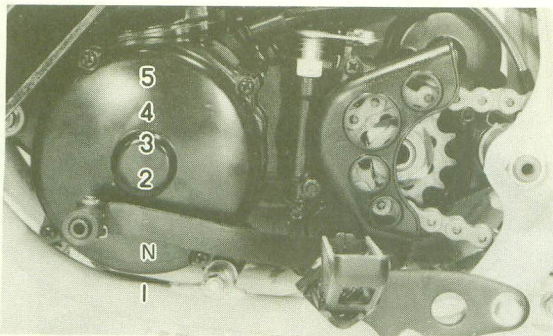

N. Neutral

Fuel tank cap

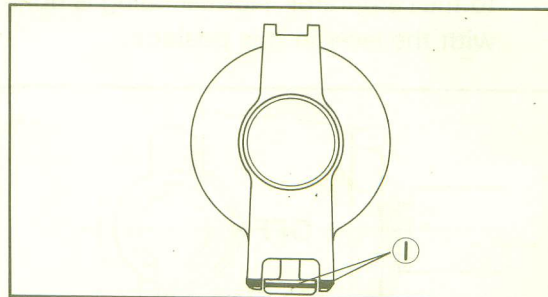

1. Marks

Align cap and lever marks correctly.
If misaligned, press again.

1. Close.
- When starting a warm engine.
2. Half-open.
- When warming up the engine.
3. Fully open.
- When starting a cold engine.

Starter knob

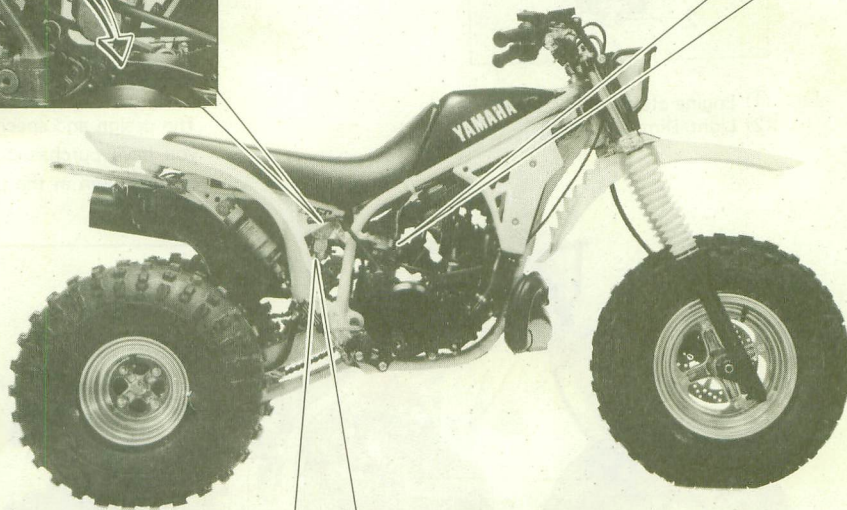
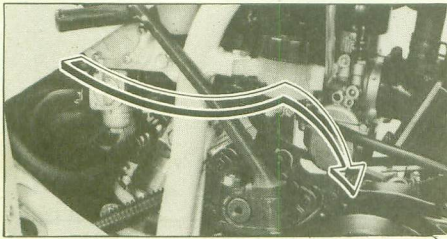
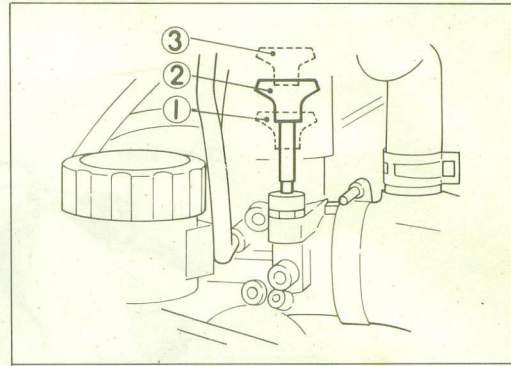

Main fuel cock

OFF: With the lever in this position fuel will not flow. Always return the lever to this position when the engine is not running.

ON: With the lever in this position fuel flows to the carburetor. Normal riding is done with the lever in this position.

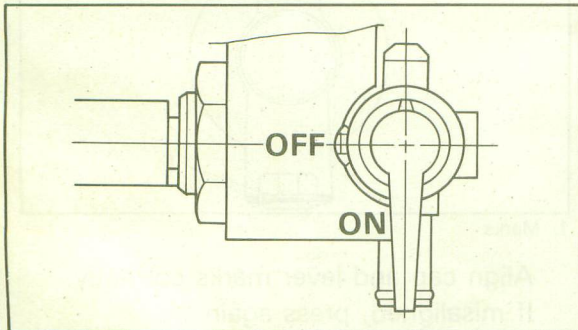

Reserve fuel cock

RES: This indicates "RESERVE". If you run out of fuel while riding, move the lever to this position. THEN, FILL THE TANK AT THE FIRST OPPORTUNITY. After refuelling, the fuel cock lever should be at "ON".

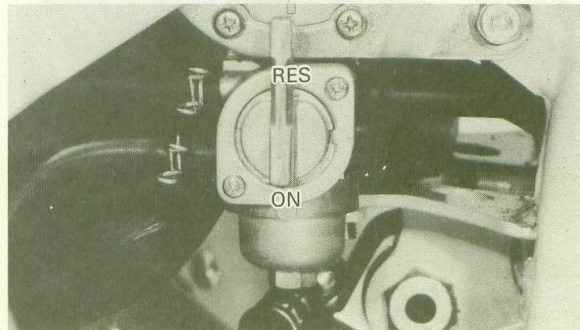

FUEL, OIL AND COOLANT

Fuel

Recommended fuel:
Premium fuel with an octane rating of
at least 90.

Fuel tank capacity:
10.0 L (2.2 Imp gal, 2.6 US gal)

Engine Mixing Oil

Recommended oil: Yamalube "R"
(Yamalube Racing 2-cycle oil)
Mixing ratio: 24:1

If for any reason you should use another type,
select from the following list.

Recommended oil	Mixing ratio (Break-in)
Castrol R30 A545* A747	20 : 1

*In Germany brand name is Castrol T.T.S., but same quality as A545.

CAUTION:

Never mix two types of oil in the same
batch; clotting of the oil could result.

Transmission Oil

Recommended oil:
Yamalube 4-cycle oil or SAE
10W30 SE motor oil

Transmission oil capacity:
Periodic oil change:
1000 cm³ (0.88 Imp qt, 1.06 US qt)
Overhaul:
1050 cm³ (0.92 Imp qt, 11.0 US qt)

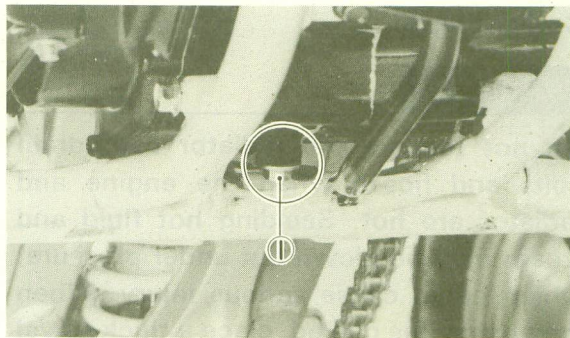

1. Drain plug

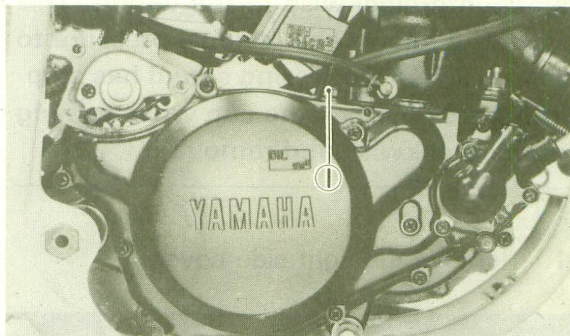

1. Filler plug

CHECKING OIL LEVEL

On the right side of the engine there is a
checking screw. To check, warm up the
engine for 1 minute. Stop engine. Leave the
engine as it is for a few minutes and place the
machine upright, then remove the oil level
checking screw. If oil flows out, the oil level
is correct.

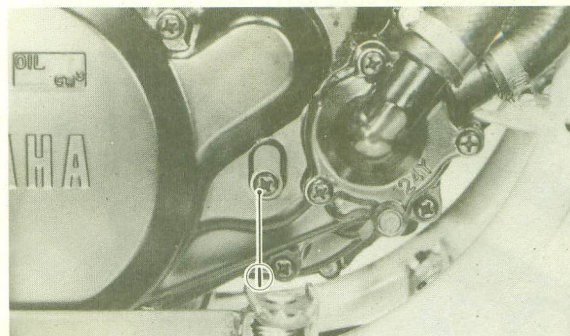

1. Checking screw

Coolant Level

WARNING:

Do not remove the radiator cap, drain bolts and hoses when the engine and radiator are hot. Scalding hot fluid and steam may be blown out under pressure, which could cause serious injury. When the engine has cooled, place a thick towel over the radiator cap, slowly rotate the cap counterclockwise to the detent. This procedure allows any residual pressure to escape. When the hissing sound has stopped, press down on the cap while turning counterclockwise and remove it.

1. Remove the right side cover.

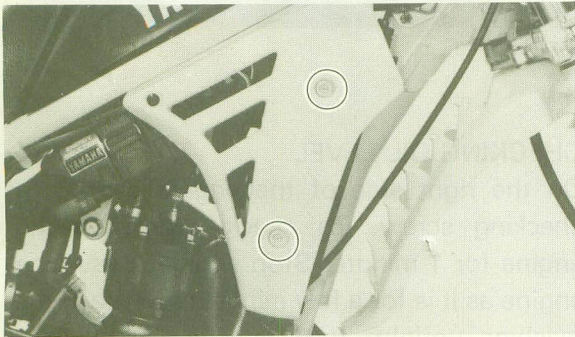

2. Check the coolant level in the radiator tank when the engine is cold. If the coolant level is low, add the coolant.

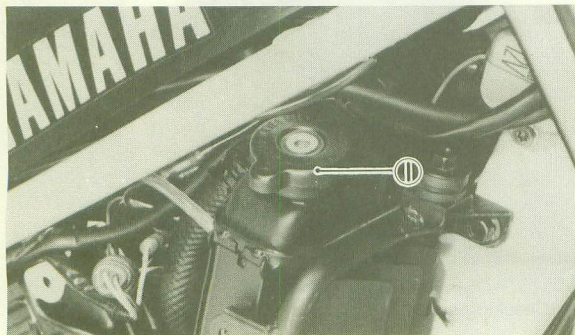

1. Radiator cap

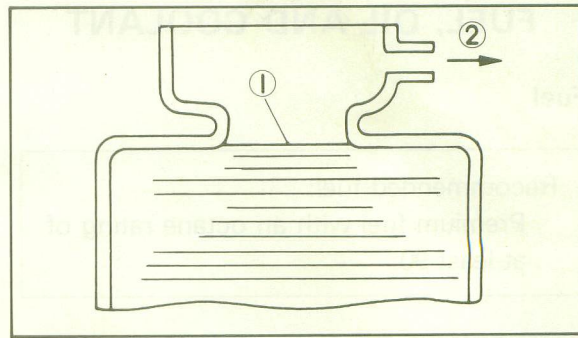

1. Coolant level
2. To recovery tank

Recommended coolant:

High quality ethylene glycol antifreeze containing corrosion inhibitors for aluminum engine

Coolant capacity:

1.0 L (0.88 Imp qt, 1.057 US qt)

Coolant and water mixed ratio:

1 : 1 (50% water, 50% coolant)

CAUTION:

Do not mix more than one type of ethylene glycol antifreeze containing corrosion for aluminum engine inhibitors. Hard water or salt water is harmful to the engine parts. You may use distilled water, if you can't get soft water.

Coolant Draining

1. Place a container under the engine.
2. Remove the radiator tank cap.
3. Gently loosen the pump cover drain screw to drain the coolant, and remove the cylinder drain bolt.

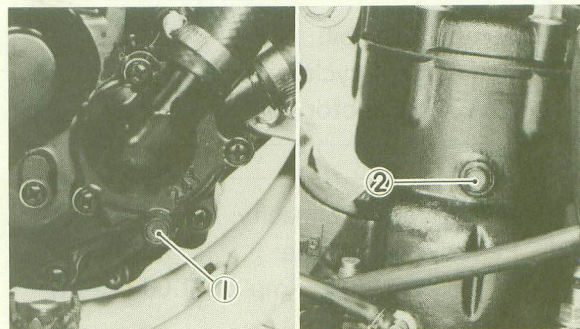

1. Pump cover drain bolt
2. Cylinder drain bolt

4. Drain the coolant completely. Thoroughly flush the cooling system with clean tap water.

CAUTION:

Take care so that coolant does not splash on painted surfaces. If it splashes, wash it away with water.

5. Retighten the drain bolts.
If the gasket is damaged, replace it.

Replenishing Coolant

NOTE:

Before pouring the coolant into the radiator, check the cooling system for damage, loose joints or leaks.

1. Pour the recommended coolant into the radiator up to the specified level.
2. After starting the engine, race the engine a few times and add the coolant again up to the specified level.
3. When the coolant level becomes stable, stop the engine and tighten the radiator cap.

RIDING AND PARKING

Riding

1. Basic riding techniques

The rear wheels of the Yamaha TRI-ZINGER are not fitted with a differential gear system to maintain better off-road traction. This requires some technique when you want to negotiate a turn.

Practice the turning technique well for the safety and enjoyment of your Yamaha TRI-ZINGER ride.

When negotiating a turn:

- Steer the handlebars in the direction of the turn.
- Lean yourself to the inside of the turn while supporting your weight on the outer footrest.
- Adjust the throttle so the rear wheels can be provided with appropriate power all through the turn.

As you master the above techniques, you will be able to negotiate a turn of a much smaller radius.

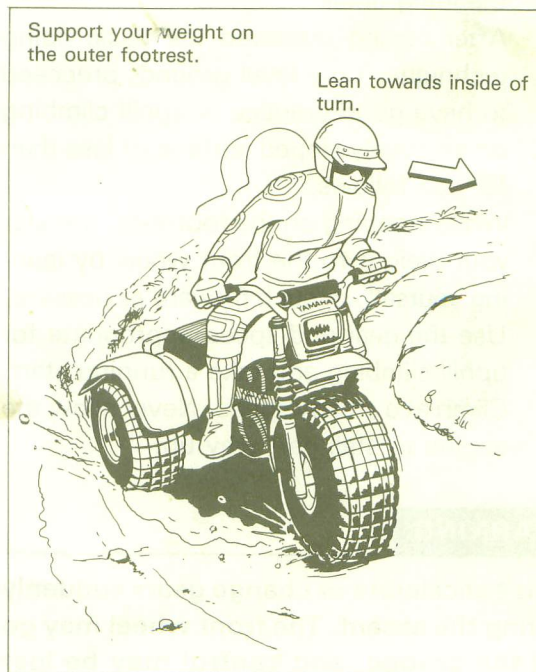

WARNING:

Begin to practice turning techniques at a speed which is slow enough. An incorrect turning technique will make it difficult for you to negotiate a turn.

To maneuver a slippery surface, you must be able to control both the front and the rear wheel skid. However, as skidding involves an inherent hazard, never fail to learn the basic riding techniques before proceeding to skidding maneuvers.

- Front wheel skidding may be corrected by leaning forward to transfer additional weight to the front wheel.
- Rear wheel skidding may be corrected by steering in the direction of the skid. Skidding maneuvers require a high degree of technique and must be performed with enough attention paid to safety.

WARNING:

Skidding maneuvers may not work on an extremely slippery or frictional surface (e.g., on ice or a paved surface) resulting in the inability to negotiate a turn or in a turnover. It is advisable to avoid skidding maneuvers under such a condition.

2. Climbing uphill

After having mastered the basic riding techniques on a level ground, proceed to have good practice in uphill climbing on an evenly sloped surface of less than 15°, as follows.

- While standing on the footrests, transfer your weight to the front wheel by leaning yourself as much forward as possible.
- Use the gear and speed appropriate for uphill climbing and take a running start. Climb at a steady speed. Never allow the engine to stall part way up.

WARNING:

Don't accelerate or change gears suddenly during the ascent. The front wheel may go off the ground, and control may be lost with a possibility of a backward overturn. If it is becoming difficult to continue the ascent, turn around cautiously for the descent while your TRI-MOTO still has

enough power. If the machine should come to a stop part way up, get off and turn it around physically. If the machine cannot be turned around, shift into neutral and slowly back down. While backing down, don't apply the rear brake. It may lead to an overturn. It is strongly advised, however, that in such a condition the machine be turned around for the descent rather than backing down the hill.

After enough practice, you will be able to ride more challenging terrain. Remember that enjoyment and safety are totally dependent upon the proper judgement of your skill, terrain, etc.

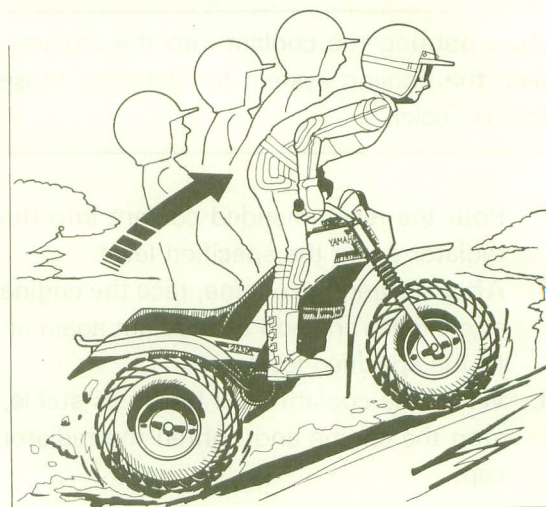

3. Going downhill

When going downhill, always survey and watch for any obstacle beyond the limit of your visibility.

- Choose as flat a surface as possible and descend the hill straight down slowly in low gear with the throttle closed.
- Shift your weight as much rearward as possible with your arms extended and braced on the handlebars.
- When going down a sand dune, apply the brake intermittently to reduce the acceleration of the machine speed.

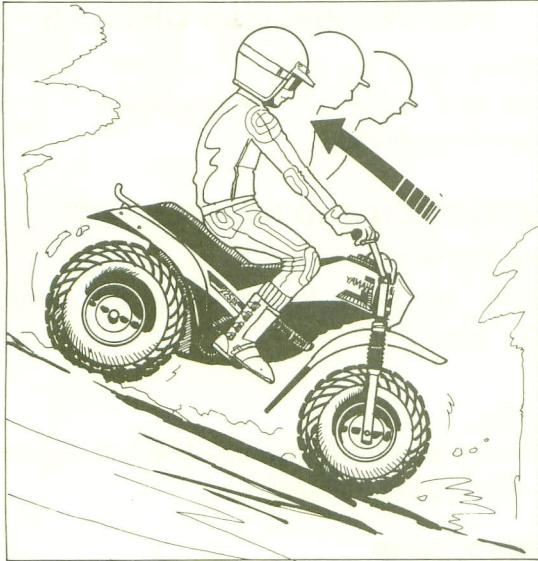

4. Traversing slopes

While traversing a slope, shift your weight uphill for stability and balance. On a loose surface such as sand, steering slightly uphill will help with your course of direction.

WARNING:

When tilted to one side, the TRI-MOTO has more precarious balance. Avoid crossing a slippery or difficult slope.

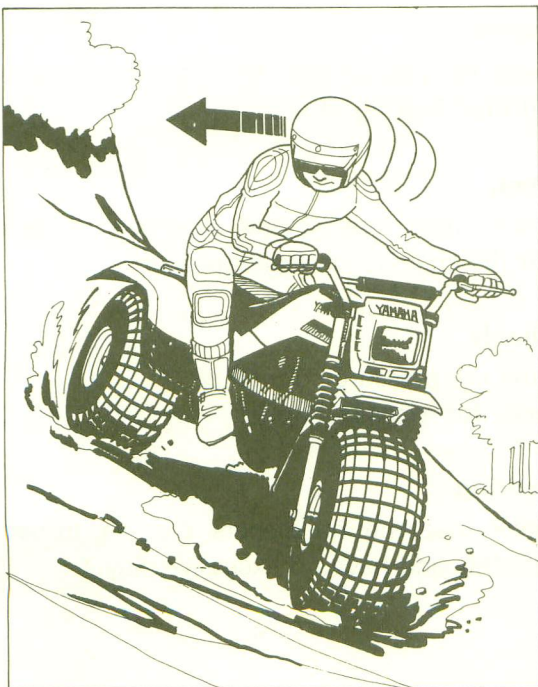

5. Riding on shallows

The TRI-ZINGER can be run in the water to a depth of an approximate maximum of 30cm (12 in). Don't go beyond this limit.

WARNING:

- Don't cross such a rapid stream as will make the tires float. This may result in loss of control.
- Choose a stream with both banks having a gradual incline. Carefully avoid obstacles and slippery rocks that may be submerged in the river bed and proceed slowly and steadily.
- After crossing the stream, test the brakes repeatedly at a slow speed as they may be less effective due to water. If the brakes continue to be less effective, stop riding and wait until the brakes are dry and regain effectiveness.

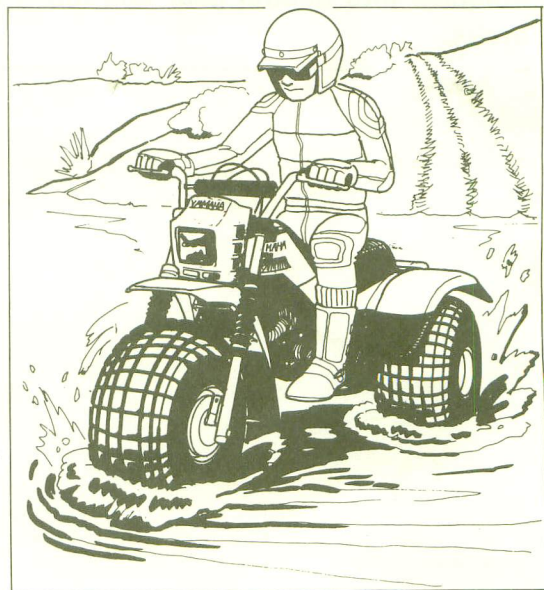

CAUTION:

Wash the machine with fresh water after riding in muddy or salty water.

Parking

When parking, stop the engine and shift into neutral, turn the fuel cock to "OFF".

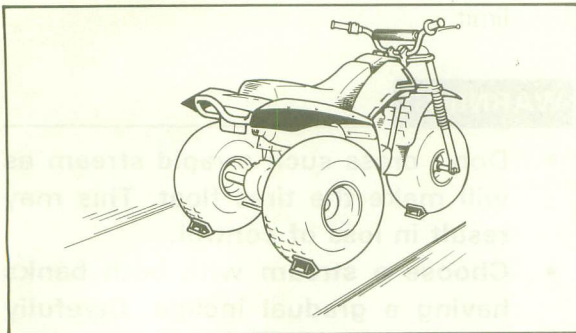

NOTE: _____

Avoid parking on an incline. If you must park on a hill, place the machine transversely across the incline. Put the machine in low gear.

WARNING: _____

When starting the engine, always put the machine into neutral gear and apply the brake.

PREOPERATION CHECKS

Before riding for break-in operation, practice or a race, make sure the machine is in good operating condition.

INSPECTION AND MAINTENANCE

Cooling water

Check that water is filled up to the radiator filler cap.

Fuel

Check that a fresh mixture of oil and gasoline is filled in the fuel tank.

WARNING: _____

Do not overfill the fuel tank. Avoid spilling fuel on the hot engine.

Do not fill the fuel tank all the way to the top or it may overflow when the fuel heats up later and expands.

After refueling, make sure the tank cap is closed securely.

Gear oil

Check that the gear oil level is correct.

Gear shifter and clutch

Check that gears can be shifted correctly in order and that the clutch operates smoothly.

Brakes

Check the play of both front and rear brakes and their braking effect.

Chain

Check chain tension and alignment. Check that the chain is lubricated properly.

Wheels

Is the tire pressure correct?

Check for excessive wear.

Steering

Check that the handlebars can be turned smoothly and have no excessive play.

Front forks and rear shock

Check that they operate smoothly and there is no oil leakage.

Cables (Wires)

Check that the clutch, brake and throttle cables move smoothly. Check that they are not caught when the handlebars are turned or when the front forks travel up and down.

Muffler

Check that the muffler is tightly mounted and has no cracks.

Sprocket

Check that the rear wheel sprocket tightening bolt is not loose.

Bolts and nuts

Check the chassis and engine for loose bolts and nuts.

Fuel, oil and coolant

Check the fuel tank, fuel cock, carburetor, engine bottom, and cooling system for leakage.

Lead wire connectors

Check that the CDI magneto, CDI unit, and ignition coil are connected tightly.

Settings

Is the machine set suitably for the condition of the racing course and weather or by taking into account the results of test-runs before racing? Is inspection and maintenance completely done?

- * The machine should be checked and serviced regularly so that only a simple, minor adjustment of settings is required prior to a race.

STARTING AND BREAK-IN

CAUTION:

Before starting the machine, perform the checks in the preoperation check list.

WARNING:

- Avoid "wheelies" and jumping to prevent loss of control.
- Always put your feet on the footrests during operation. If you should take your feet off the footrests, they may contact the rear wheels.
- Never start or run the engine in a closed area. The exhaust fumes are poisonous; they can cause loss of consciousness and death in a very short time. Always operate the machine in a well-ventilated area.

Starting a Cold Engine

Shift the transmission into *neutral*. Turn on the fuel cock and full open the starter knob on the carburetor. With the throttle completely closed, kickstart the engine with a smooth, firm stroke. Half-open the starter knob, run the engine at idle or slightly higher until it warms up; this usually takes about one or two minutes. The engine is warmed up when it responds normally to the throttle with the starter knob pushed completely down.

CAUTION:

Do not warm up the engine for extended periods.

Starting a Warm Engine

Do not raise the starter knob. Open the throttle slightly and kickstart the engine with a smooth, firm stroke.

CAUTION:

Observe the following break-in procedures during initial operation to ensure optimum performance and avoid engine damage.

Break-in Procedures

1. Before starting the engine, fill the fuel tank with a break-in oil-fuel mixture of 12:1 to 14:1.
2. Perform the preoperation checks on the machine.
3. Start and warm up the engine. Check the idle speed, and check the operation of the controls and the engine stop switch.
4. Operate the machine in the lower gears at moderate throttle openings for five to eight minutes. Stop and check the spark plug condition; it will show a rich condition during break-in.
5. Allow the engine to cool. Restart the engine and operate the machine as in the step above for five minutes. Then, very briefly shift to the higher gears and check full-throttle response. Stop and check the spark plug.
6. After again allowing the engine to cool, restart and run the machine for five more minutes.
Full throttle and the higher gears may be used, but sustained full-throttle operation should be avoided. Check the spark plug condition.
7. Allow the engine to cool, remove the top end, and inspect the piston and cylinder; instructions for this are described Chapter 3 "CYLINDER HEAD". Remove any high spots on the piston with 600-grit, wet sandpaper. Clean all components and carefully reassemble the top end.
8. Drain the break-in oil-fuel mixture from the fuel tank and refill with the specified mix. Check the entire machine for loose screws, bolts, and nuts.
9. Restart the engine and check the operation of the machine throughout its entire operating range. Stop and check the spark plug condition. Restart the machine and operate it for about 10 to 15 more minutes. The machine will now be ready to race.

CAUTION:

1. After the break-in period is completed, check the entire machine for loose fittings and fasteners. Tighten all such fasteners as required.
2. When any of the following parts have been replaced, they must be broken in.

CYLINDER AND CRANKSHAFT:

About one hour of break-in operation is necessary.

PISTON, RINGS, GEARS:

These parts require about 30 minutes of break-in operation at half-throttle or less. Observe the condition of the engine carefully during operation.

CLEANING AND STORAGE

Cleaning

Frequent cleaning of your machine will enhance its appearance, maintain good overall performance, and extend the life of many components.

1. Before washing the machine, block off the end of the exhaust pipe to prevent water from entering. A plastic bag secured with a rubber band may be used for this purpose.
2. If the engine is excessively greasy, apply some degreaser to it with a paint brush. Do not apply degreaser to the chain, sprockets, or wheel axles.
3. Rinse the dirt and degreaser off with a garden hose; use only enough pressure to do the job.

CAUTION:

Excessive hose pressure can force water into wheel bearings, front fork seals, and transmission seals. Avoid using high-pressure hoses such as those found in coin-operate car washes.

4. After the majority of the dirt has been hosed off, wash all surfaces with warm water and a mild detergent. Use an old toothbrush to clean hard-to-reach places.
5. Rinse the machine off immediately with clean water, and dry all surfaces with a soft towel or cloth.
6. Immediately after washing, remove excess water from the chain with a paper towel and lubricate the chain to prevent rust.
7. Clean the seat with a vinyl upholstery cleaner to keep the cover pliable and glossy.
8. Automotive wax may be applied to all painted or chromed surfaces. Avoid combination cleaner-waxes, as they may contain abrasives.
9. After completing the above, start the engine and allow it to idle for several minutes.

Storage

If your machine is to be stored for 60 days or more, some preventive measures must be taken to avoid deterioration. After cleaning the machine thoroughly, prepare it for storage as follows:

1. Drain the fuel tank, fuel lines, and the carburetor float bowl.
2. Remove the spark plug, pour a tablespoon of SAE 10W30 motor oil in the spark plug hole, and reinstall the plug. With the engine stop switch pushed in, kick the engine over several times to coat the cylinder walls with oil.
3. Remove the drive chain, clean it thoroughly with solvent, and lubricate it. Reinstall the chain or store it in a plastic bag tied to the frame.
4. Lubricate all control cables.
5. Block the frame up to raise the wheels of the ground.
6. Tie a plastic bag over the exhaust pipe outlet to prevent moisture from entering.
7. If the machine is to be stored in a humid or salt-air environment, coat all exposed metal surfaces with a film of light oil. Do not apply oil to rubber parts or the seat cover.

NOTE:

Make any necessary repairs before the machine is stored.

2 REGULAR MAINTENANCE AND ADJUSTMENT

MAINTENANCE INTERVALS	2-1
LUBRICATION	2-3
SPECIAL TOOLS	2-5
For Tune-up	2-5
For Engine Service	2-5
For Chassis Service	2-6
For Electrical Components	2-6
MINOR MAINTENANCE AND ADJUSTMENTS	2-6
Spark Plug.....	2-6
Ignition Timing	2-7
Throttle Lever Adjustment	2-8
Idle Speed	2-8
Air Filter	2-8
Clutch	2-9
Front Brake Adjustment.....	2-10
Rear Brake Pedal Height Adjustment.....	2-10
Checking the Front and Rear Brake Pads	2-10
Inspecting the Brake Fluid Level.....	2-10
Drive Chain Tension Check	2-11
Drive Chain Tension Adjustment.....	2-11
Drive Chain Cleaning and Lubrication	2-12
Steering Head Adjustment	2-12
Wheel Bearings	2-13
Fuel Cock.....	2-14
Tires	2-14
Cable Inspection and Lubrication.....	2-15
Brake and Change Pedal/Clutch and Brake Levers.....	2-15
Headlight Bulb Replacement	2-15
Headlight Beam Adjustment.....	2-15

2 MAINTENANCE INTERVALS CHART

The following schedule is intended as a general guide to maintenance and lubrication. Bear in mind that such factors as weather, terrain, geographical location, and individual usage will alter the required maintenance and lubrication intervals. If you are in doubt as to what intervals to follow in maintaining and lubricating your machine, consult your Yamaha dealer.

WARNING:

Be sure to turn off the engine when you perform maintenance unless otherwise specified.

Item	After break-in	Every race	Every 30 operation days	Every year	As required	Remarks
PISTON Inspect and clean Replace		●			● ●	Inspect crack Remove carbon
PISTON RINGS Inspect Replace		●			● ●	Check ring end gap
PISTON PIN, SMALL END BEARING Inspect Replace				●	● ●	
CYLINDER HEAD Inspect and clean Retighten		● ●			● ●	Remove carbon
CYLINDER Inspect and clean Replace					● ●	seizure wear
Y.E.I.S. Inspect		●		●		
AIR FILTER Clean and oil Replace	●	●	●		●	Use Foam air-filter oil
CLUTCH Inspect and adjust Replace	●	●	●		●	Inspect friction plate, clutch plate and spring
TRANSMISSION Replace oil Inspect transmission	●			●	●	Yamalube 4-cycle oil or SAE 10W30 SE motor oil
SHIFT CAM, FORK Inspect					●	Inspect wear
ROTOR NUT Retighten				●		
MUFFLER (Spark Arrester) Inspect Clean			●		●	
CRANK Inspect and clean					●	
CARBURETOR Inspect, adjust and clean	●		●			
SPARK PLUG Inspect and clean Replace	●	●	●		●	STD plug: B8ES

Item	After break-in	Every race	Every 30 operation days	Every year	As required	Remarks
DRIVE CHAIN Lubricate, free play, alignment Replace	●	●	●		●	Use chain lube or SAE30 ~ 50 motor oil Free play: 30 ~ 35 mm (1.2 ~ 1.4 in)
OUTSIDE NUTS AND BOLTS Retighten	●	●	●			
FRAME Clean and inspect		●				
FUEL TANK, COCK Clean and inspect	●		●	●		
BRAKES Adjust free play Lubricate pivot point Replace pads Check fluid leakage	● ●	● ●	● ●		● ● ●	See NOTE Pad wear limit: 0.8 mm (0.032 in) DOT #3
FRONT FORKS Inspect and adjust Replace oil Replace oil seal				● ● ●		Yamaha fork oil 10 wt
REAR SHOCK Inspect and adjust Lube and retighten	●	●	●			Lithium base grease
CHAIN GUARD AND ROLLERS Inspect and replace					●	Wear and alignment
SWINGARM Inspect lube and retighten	●		●			Lithium base grease
RELAY ARM, CONNECTING ROD Inspect and lube	●		●			Lithium base grease
STEERING HEAD Inspect free play and retighten Clean and lube Replace bearing	● ●			● ●	●	Medium weight wheel bearing grease
TIRE, WHEELS Inspect air pressure, wheel run-out, and tire wear Retighten sprocket bolt Inspect bearings Replace bearings Lubricate	● ●		● ● ● ●		●	Medium weight wheel bearing grease
THROTTLE, CONTROL CABLE Check routing and connection Lubricate	● ●		● ●			Yamaha cable lube SAE 10W30 motor oil

NOTE: _____

Brake fluid replacement:

1. When disassembling the master cylinder or caliper cylinder, replace the brake fluid. Normally check the brake fluid level and add the fluid as required.
2. On the inner parts of the master cylinder and caliper cylinder, replace the oil seals every two years.
3. Replace the brake hoses every four years, or if cracked or damaged.

LUBRICATION

To ensure smooth operation of all components, lubricate your machine during setup, after braking, and after every race.

Before lubricating, thoroughly clean the machine of sand, dirt and water.

- A. Use Yamaha cable lube, or WD-40 on these areas.
- B. Use chain lube or SAE 30~50 motor oil.

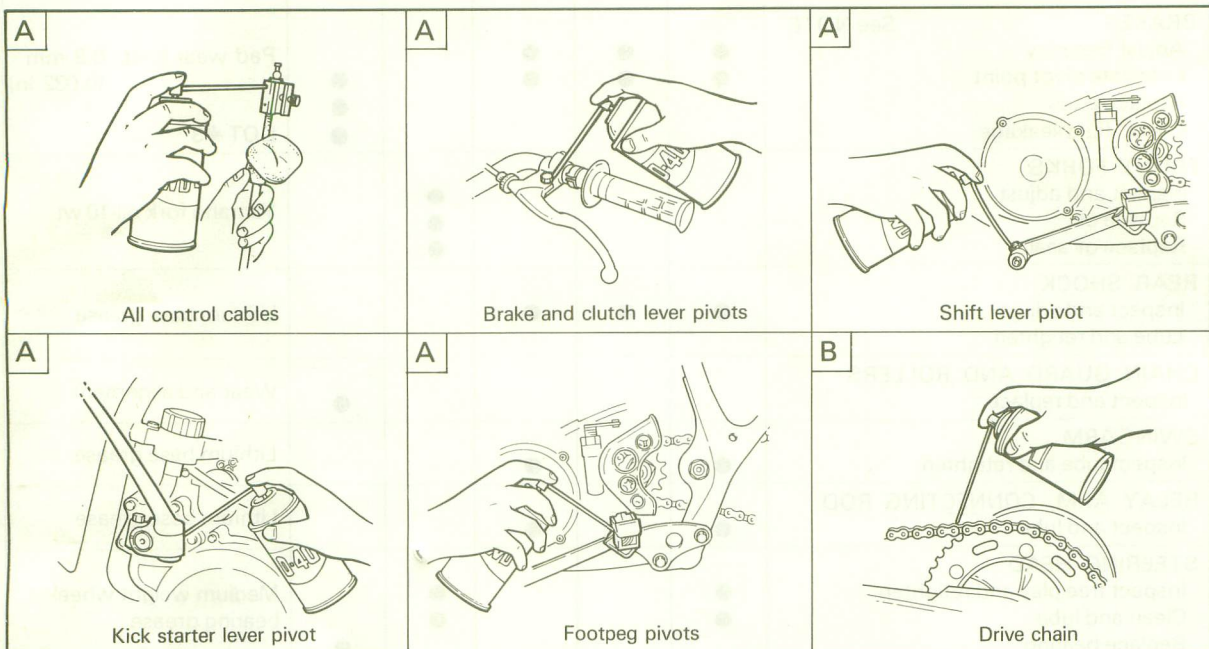

C. Lubricate the following areas with high-quality, lithium base grease:

CAUTION:

Wipe off any excess grease, and avoid getting grease on the brake shoes.

<p>Throttle lever and wire end</p>	<p>Clutch wire ends</p>	<p>Wheel axle collar</p>
<p>Wheel axles and pivot shaft</p>	<p>Rear wheel bearing and oil seal</p>	<p>Swingarm bearing, bushing, and oil seal</p>
<p>Relay arm bearing and oil seal</p>	<p>Connecting rod bearing and oil seal</p>	
<p>Rear shock pivot (upper and lower)</p>	<p>Steering head bearings</p>	

SPECIAL TOOLS

The following special tools are required to perform maintenance, adjustments, and repairs on your machine. These tools can be obtained through your Yamaha dealer.

For Tune-up

1 Dial gauge
YU-03097

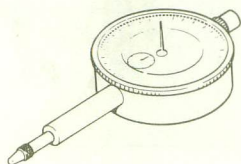

2 Dial gauge stand
YU-01256-1

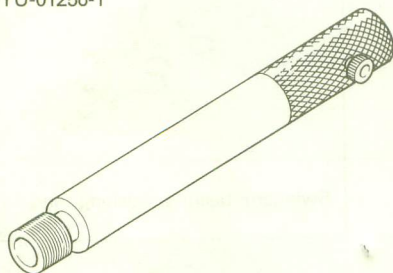

3 Dial gauge extension
YU-01256-2

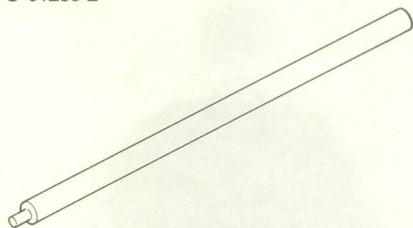

Tools 1, 2 and 3 are used to set the ignition timing.

For Engine Service

1 Clutch holding tool
YM-91042

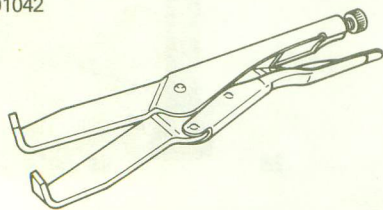

Use this tool to hold the clutch boss while removing or tightening the clutch boss nut.

2 Crankcase separating tool
YU-01135

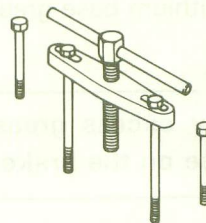

This tool is used to split the crankcases as well as remove the crankshaft from either case.

3 Crankshaft installing tool
YU-90058

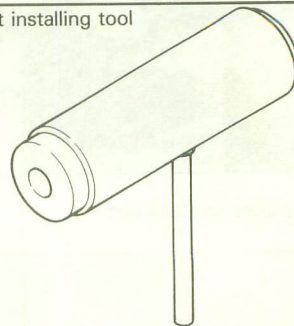

4 Spacer
YU-90059

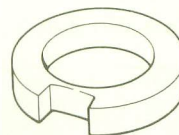

5 Crankshaft installing bolt and adapter
(YU-90060, YU-90062)

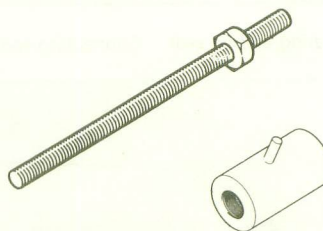

Tools 6, 7 and 8 are used to install the crankshaft.

6 Rotor puller
YM-55500

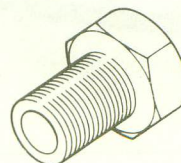

This tool is used to remove the magneto.

For Chassis Service

- 1 Steering nut wrench
YU-01268

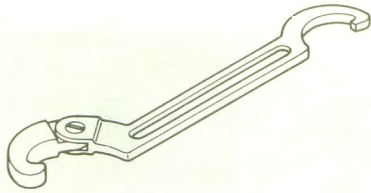

Use this wrench to put the proper tension on the steering head bearings.

- 2 For cylinder holder and adapter
YM-01300, YM-01326

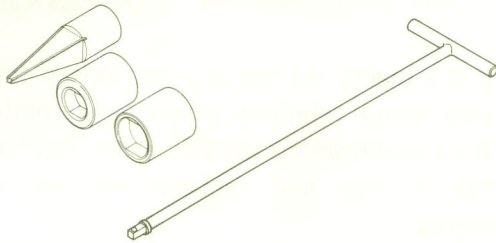

Use these tools to remove and install the fork cylinder.

- 3 Fork seal and bushing service tool
YM-33963, YM-1369

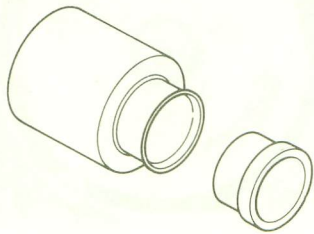

This tool is used to install the fork oil seal.

For Electrical Components

- 1 Yamaha pocket tester
YU-03112

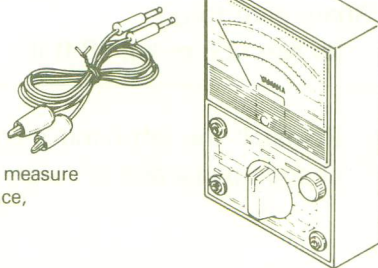

Use this tool to measure the coil resistance, output voltage and amperage.

MINOR MAINTENANCE AND ADJUSTMENTS

Spark Plug

Standard spark plug:
B8ES (NGK)

Spark plug gap:
0.7 ~ 0.8 mm (0.03 ~ 0.031 in)

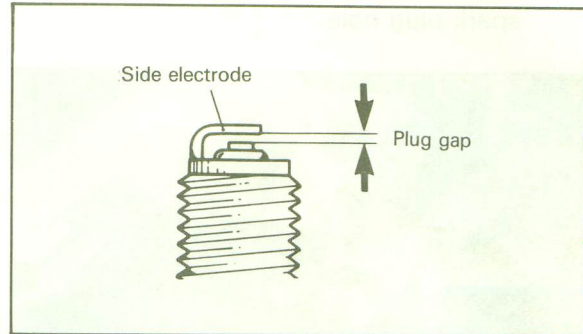

1. Whenever a new spark plug is installed, the gap must be checked and adjusted properly. Use a wire feeler gauge to check the gap, and adjust the gap by bending the side electrode gently.
2. Be sure to clean the gasket surface and threads before installing the spark plug. Torque the plug to specification.

Spark plug torque:
25 Nm (2.5 m·kg, 18 ft·lb)

NOTE:

If a torque wrench is not available when you are installing a spark plug, a good estimate of the correct torque is 1/2 to 1/4 turns past finger tight. Have the spark plug torque to the correct value as soon as possible with a torque wrench.

Ignition Timing

The ignition timing must be set precisely to ensure that the ignition spark occurs at the proper time to provide optimum engine power.

1. Remove the spark plug, left side cover, change pedal, and the left-hand crankcase cover.
2. Install the extension on the dial gauge, and slide the dial gauge assembly into the dial gauge stand.
3. Screw the dial gauge stand into the spark plug hole.

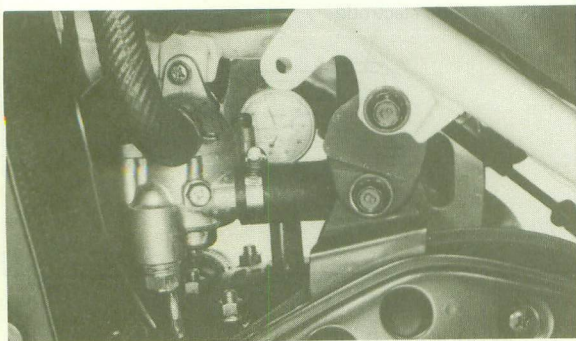

4. Rotate the magneto rotor until the piston reaches top dead center (TDC). When this happens, the needle on the dial gauge will stop and reverse directions even though the rotor is being turned in the same direction. Zero the dial gauge at TDC.

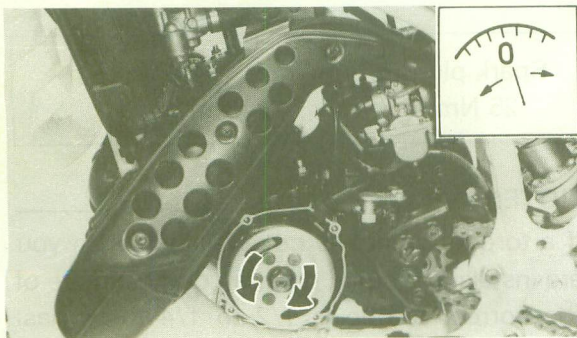

5. From TDC, rotate the rotor clockwise until the dial gauge indicates that the piston is at a specified distance from TDC. At this point, the scribed marks on the rotor and the stator plate should be aligned.

Ignition timing: B.T.D.C.

1.66 ± 0.1 mm (0.07 ± 0.004 in)

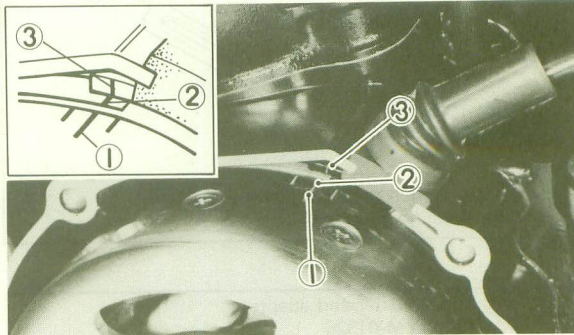

1. Rotor mark 2. Stator mark 3. Crankcase mark

6. If the marks are not aligned, loosen the two stator retaining screws and rotate the stator until the marks line up. Tighten the screws and recheck the timing marks.

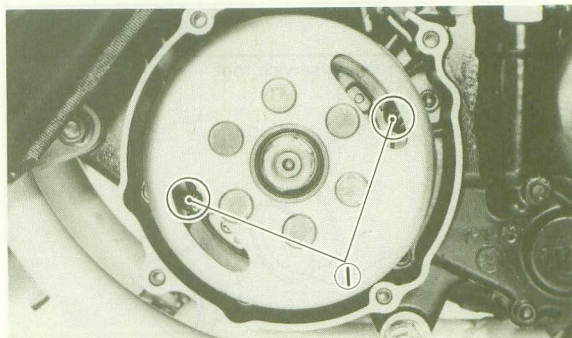

1. Retaining screws

7. Remove the dial gauge assembly and stand, and reinstall the spark plug. Torque the plug to specification.

Spark plug torque:

25 Nm (2.5 m·kg, 18 ft·lb)

8. Reinstall the left-hand crankcase cover, change pedal and left side cover.

Throttle Lever Adjustment

1. Loosen the locknut and turn the adjuster until there is the specified freeplay at throttle lever.

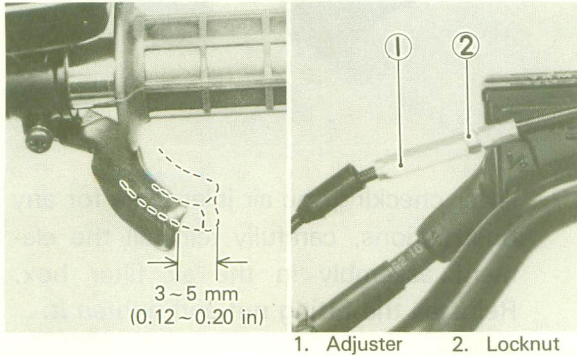

Throttle lever play:
3 ~ 5 mm (0.12 ~ 0.20 in)

2. After adjustment, start the engine and check throttle operation. Turn the handlebars from lock to lock and note if the engine speeds up; if it does, the cable adjustment is too tight and must be readjusted.

Idle Speed

1. Screw in the pilot air screw until it is lightly seated.
2. Back out by the specified number of turns. Start the engine and let it warm up.

Pilot air screw setting:
1.0 turn out

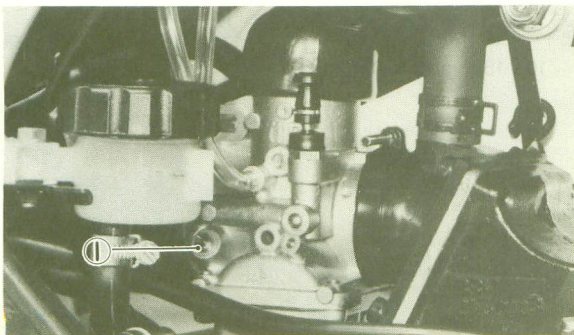

3. Loosen the locknut on the throttle stop screw and turn the screw until the idle is at the desired rpm.

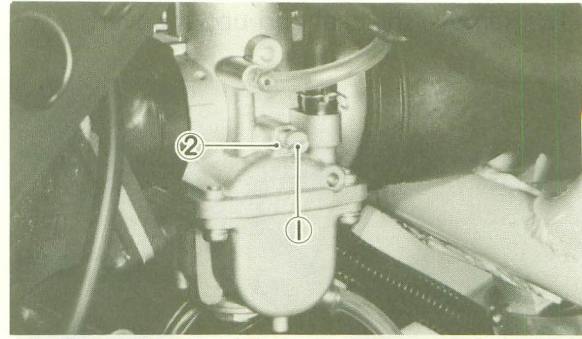

4. Turn the pilot air screw in or out in 1/8-turn increments to achieve the highest rpm with just the pilot screw.
5. Once again, turn the throttle stop screw to attain the desired idle rpm, and tighten the locknut.

The throttle response off idle should be crisp and clean, without any hesitation. If the engine is completely warmed up and hesitates off idle, turn the pilot air screw in or out in 1/8-turn increments until the problem is eliminated.

Air Filter

Proper air filter maintenance is the biggest key to preventing premature engine wear and damage. All elements of the air filter system should be maintained after every moto; engine life will be prolonged and power output will remain consistent.

CAUTION:

Never run the engine without the air filter element in place; this would allow dirt and dust to enter the engine and cause rapid wear and possible engine damage. In addition, carburetor jetting would be significantly affected, with subsequent poor performance and possible overheating.

1. Remove the seat and upper cover.

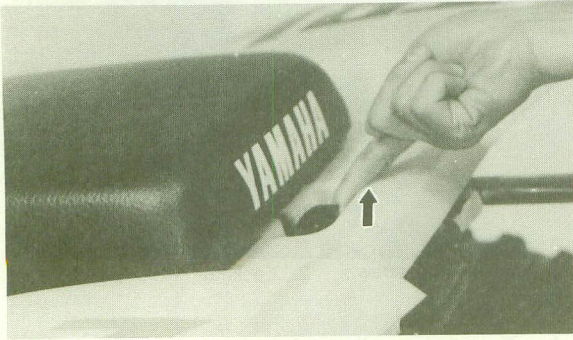

2. Remove the air filter box cover and air filter element.

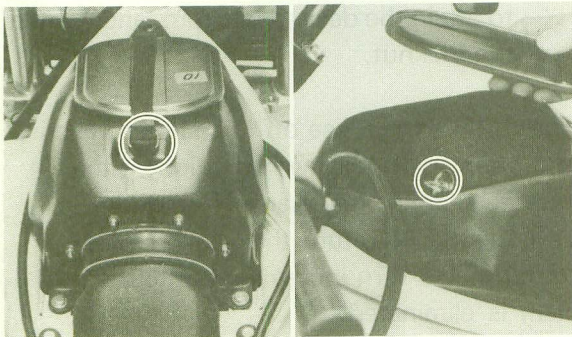

3. Separate the element from the filter cage.
4. Wash element gently but thoroughly in solvent, squeeze the solvent out of the elements, and allow the element to dry.

WARNING:

Never use low flash point solvents such as gasoline to clean the air filter element. Such solvent may lead to a fire or explosion.

5. Pour a small quantity of foam-air-filter oil or motor oil on the element and work it thoroughly into the foam. Squeeze out the excess oil.

CAUTION:

Do not twist the filter element when squeezing the filter element.

6. Reinstall the element on the filter cage, and coat the sealing edge of the element assembly with light grease to provide an airtight seal.

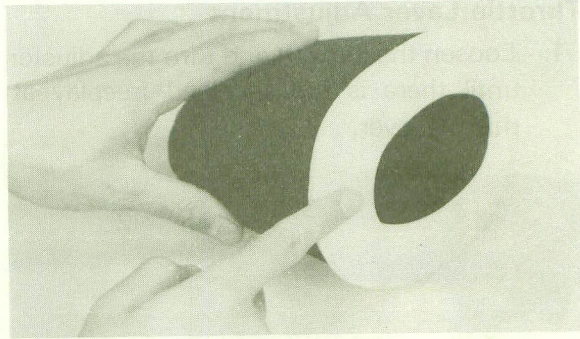

7. After checking the air inlet hose for any obstructions, carefully reinstall the element assembly in the air filter box. Reinstall the fitting nut and tighten it.

CAUTION:

Do not overtighten the fitting nut to avoid distorting the filter element cage.

8. Reinstall the air filter box cover, upper cover, and seat.
9. Inspect the air filter joint and intake manifold rubber for tears and cracks. Replace them if any damage is found.

NOTE:

Each time filter element is serviced check inside air box for any signs of dirt or dust.

Clutch

To avoid clutch slipping or dragging, the clutch mechanism and cable must be adjusted correctly.

1. Adjust the cable adjuster at the handle lever to provide 10~15 mm (0.4~0.6 in) of free play at the clutch lever end tighten the locknut.

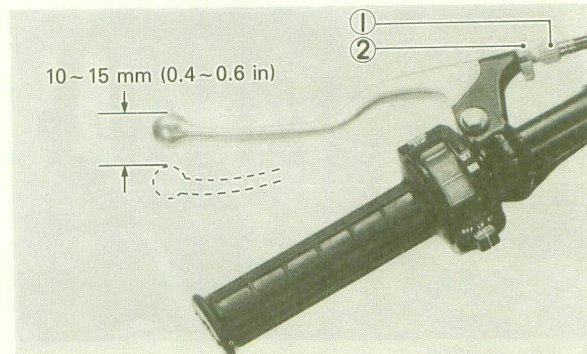

1. Adjuster 2. Locknut

For the mechanical adjustment, refer to "Clutch mechanism adjustment".

Front Brake Adjustment

The free play at the end of the front brake lever should be 4~8 mm (0.16~0.3 in).

1. Loosen the locknut.
2. Turn the adjuster so that the brake lever movement at the lever end is 4~8 mm (0.16~0.3 in) before the adjuster contacts the master cylinder piston.
3. After adjusting, tighten the locknut.

WARNING:

Check the brake lever free play. Be sure the brake is working properly.

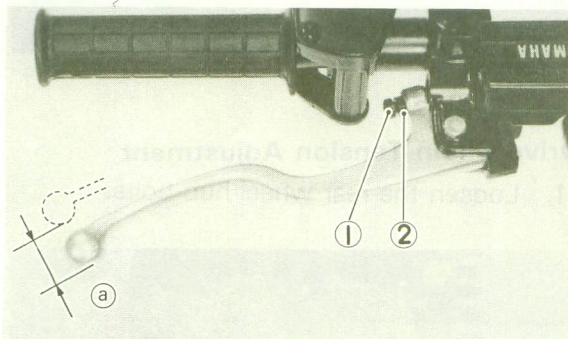

1. Adjuster 2. Locknut
a) 4~8 mm (0.16~0.3 in)

WARNING:

A soft or spongy feeling in the brake lever can indicate the presence of air in the brake system. This air must be removed by bleeding the brake system before the motorcycle is operated. Air in the system will cause greatly diminished braking capability and can result in loss of control and an accident. Have a Yamaha dealer inspect and bleed the system if necessary.

Rear Brake Pedal Height Adjustment

Loosen the locknut, and turn the adjuster to achieve the desired pedal height according to rider preference. Tighten the locknut.

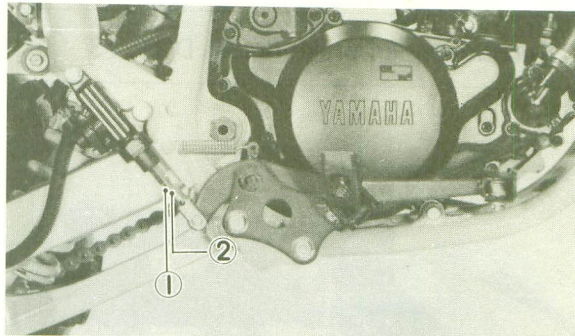

1. Adjuster 2. Locknut

Checking the Front and Rear Brake Pads

A wear indicator is attached to each brake pad to facilitate disc brake pad checks. This indicator permits a visual check without disassembling the pads. To check, depress the brake and inspect the wear indicator. If the wear indicator is ALMOST in contact with the disc plate, ask a Yamaha dealer to replace the pads.

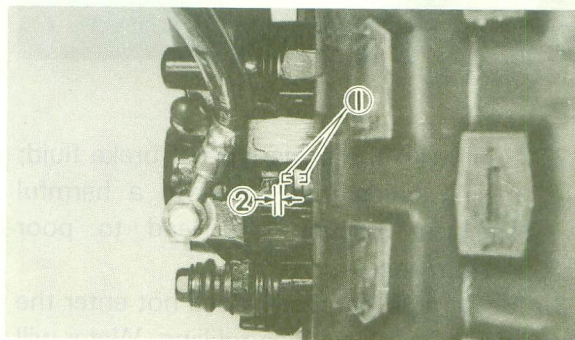

1. Wear indicator 2. Wear limit

Inspecting the Brake Fluid Level

Insufficient brake fluid may let air enter the brake system, possibly causing the brakes to become ineffective.

Before riding, check the brake fluid level and replenish when necessary; observe these precautions:

1. Use only the designated quality brake fluid: otherwise, the rubber seals may deteriorate, causing leakage and poor brake performance.

Recommended brake fluids: DOT #3

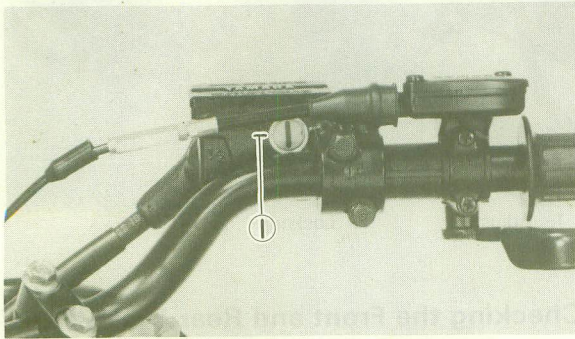

1. Lower level

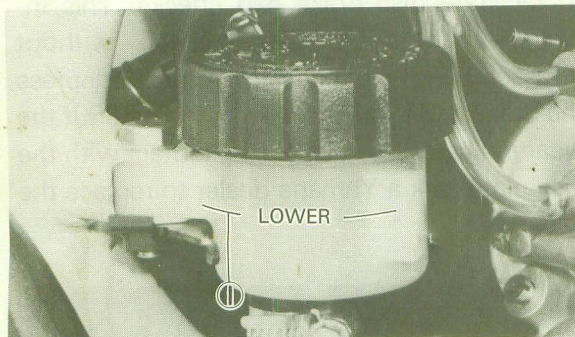

1. Lower level

2. Refill with the same type of brake fluid; mixing fluids may result in a harmful chemical reaction and lead to poor performance.
3. Be careful that water does not enter the master cylinder when refilling. Water will significantly lower the boiling point of the fluid and may result in vapor lock.
4. Brake fluid may erode painted surfaces or plastic parts. Always clean up spilled fluid immediately.
5. Have a Yamaha dealer check the cause if the brake fluid level goes down.

Drive Chain Tension Check

Inspect the drive chain with both tires touching the ground. Check the tension at the position shown in the photograph. The normal vertical deflection is approximately 30 ~ 35 mm (1.2 ~ 1.4 in). If the deflection exceeds 35 mm (1.4 in), adjust the chain tension.

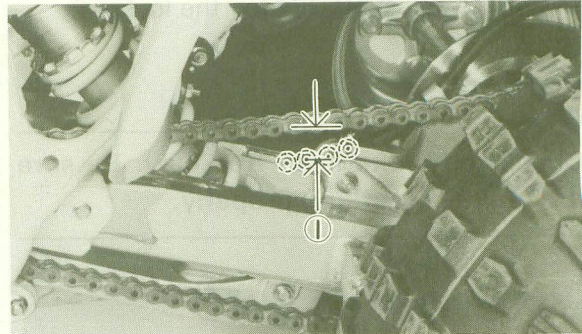

1. Deflection

Drive Chain Tension Adjustment

1. Loosen the rear wheel hub bolts.

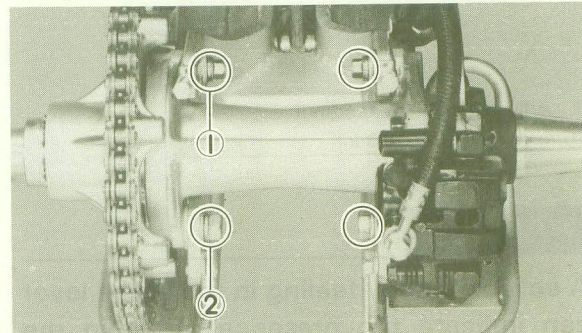

1. Upper bolt

2. Lower bolt

2. Loosen the locknuts on each side. To tighten the chain, turn chain adjuster clockwise. To loosen the chain, turn the adjuster counterclockwise and push the wheel forward. Turn each adjuster exactly the same amount to maintain correct axle alignment.
(There are marks on each side of swingarm and on each chain adjuster; use them to check for proper alignment.)

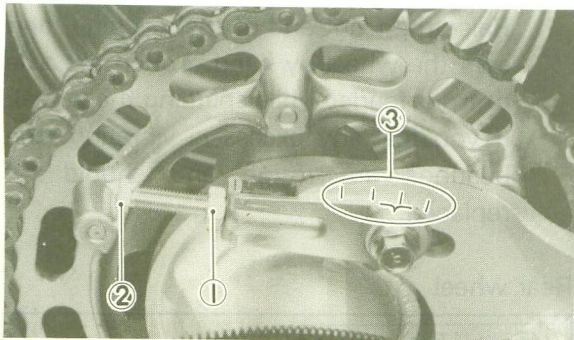

1. Locknut
2. Adjusting bolt
3. Mark for alignment

3. After adjusting, be sure to tighten the locknuts and the wheel hub bolts.

Upper wheel hub bolt:

50 Nm (5.0 m·kg, 36 ft·lb)

Lower wheel hub bolt:

80 Nm (8.0 m·kg, 58 ft·lb)

Drive Chain Cleaning and Lubrication

This machine has a drive chain with small rubber O-rings between the chain plates. Steam cleaning, high-pressure washes, and certain solvent can damage these O-rings. Use only kerosene to clean the drive chain. Wipe it dry, and thoroughly lubricate it with SAE 30 ~ 50 motor oil. Do not use any other lubricants on the drive chain. They may contain solvents that could damage the O-rings.

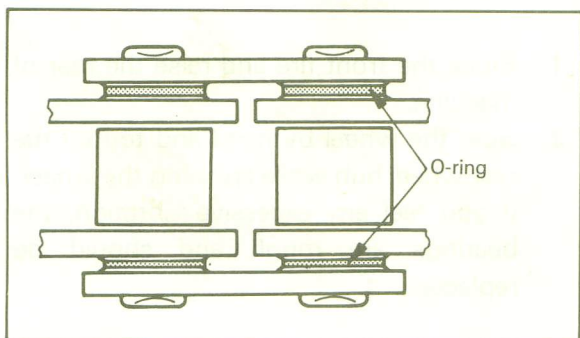

Steering Head Adjustment

The steering assembly should be checked periodically for looseness.

1. Raise the front end of the machine so that there is no weight on the front wheel.

2. Grasp the bottom of the forks and gently rock the fork assembly backward and forward, checking for looseness in the steering assembly bearings.

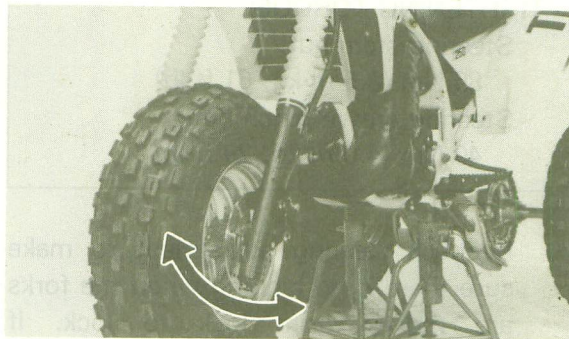

3. If the steering head is loose, adjust it. Remove the pinch bolts of the steering crown and loosen the steering stem nut.

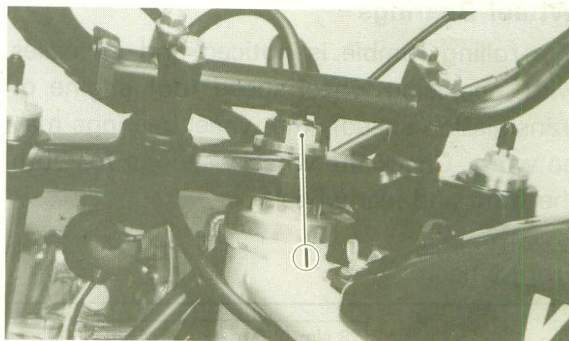

1. Steering stem nut

4. Use a ring nut wrench to tighten the steering ring nut until the steering head is tight but does not bind when the forks are turned.

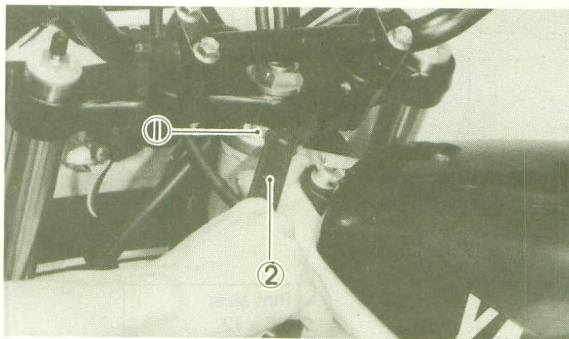

1. Steering ring nut
2. Ring nut wrench

5. Tighten the pinch bolts and steering stem nut to specification.

TIGHTENING TORQUE:

Steering stem nut:

85 Nm (8.5 m·kg, 61 ft·lb)

Steering crown pinch bolt:

40 Nm (4.0 m·kg, 29 ft·lb)

6. Recheck steering adjustment to make sure there is no binding when the forks are moved from lock to lock. If necessary, repeat the adjustment procedure.

Wheel Bearings

If a rolling rumble is noticed and increases with increasing wheel speed (not engine or transmission speed), the wheel bearings may be worn. Check the wheel bearings for both the front and rear wheels.

Front wheel

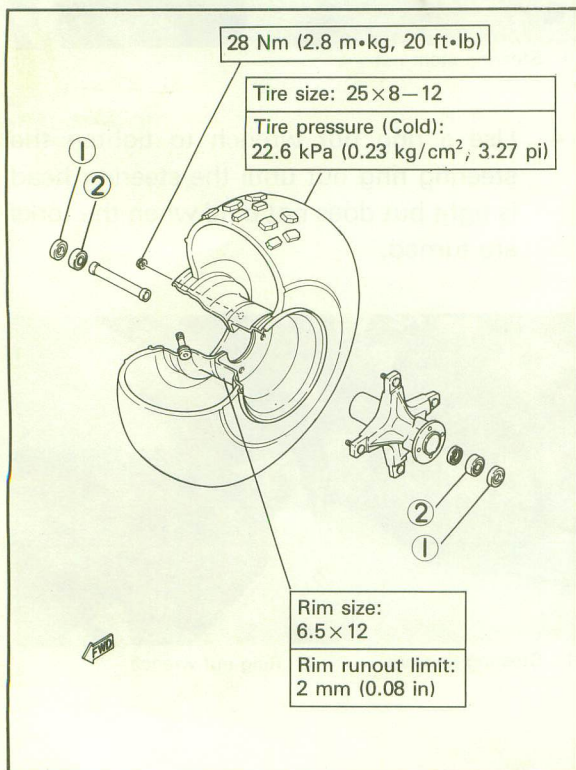

1. Oil seal
2. Bearing

1. Raise the front end of the machine, and spin the wheel by hand. Touch the axle of front fender while spinning the wheel. If you feel any excessive vibration, the bearings are rough and should be replaced.

Rear wheel

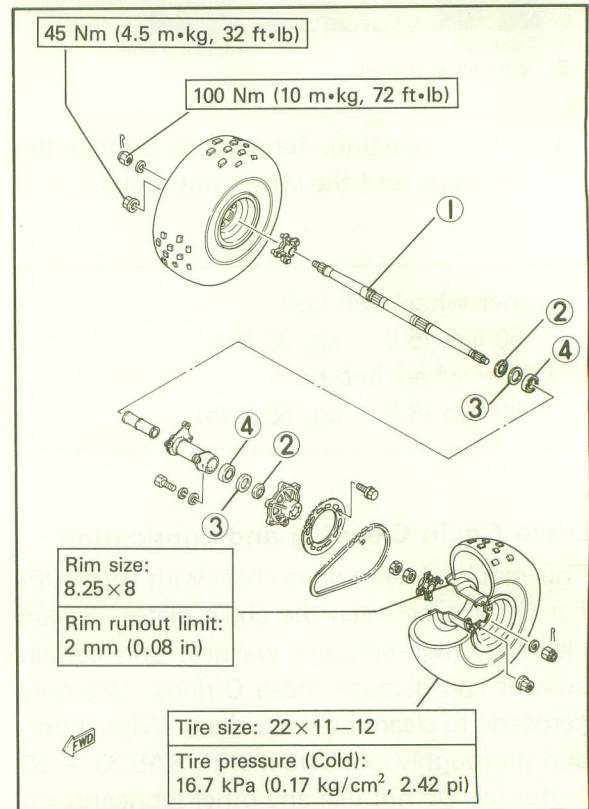

1. Rear axle
2. Dust seal
3. Oil seal
4. Bearing

1. Block the front tire and raise the rear of machine.
2. Spin the wheel by hand and touch the rear wheel hub while spinning the wheel. If you feel any excessive vibration, the bearings are rough and should be replaced.

Fuel Cock

If either fuel cock is leaking or is excessively contaminated, it should be removed and inspected.

1. Remove the fuel cock and inspect the filter screen. Replace the filter if it is seriously contaminated.
2. Remove the screws on the front and rear of the fuel cock; remove the plate, gaskets, lever, and diaphragm.
3. Inspect all components, and replace any that are damaged. If the fuel cock gasket surfaces are scratched or corroded, the fuel cock assembly must be replaced. If there is abrasive damage to any components, the fuel tank must be drained and flushed.
4. Reassemble the fuel cock and install it.
5. Connect the fuel pipe.

Tires

WARNING:

This model is equipped with low pressure tires. Pay attention to the following points:

Recommended tire pressure:

Front: 22.6 kPa (0.23 kg/cm², 3.3 psi)

Rear: 16.7 kPa (0.17 kg/cm², 2.4 psi)

Vehicle load limit: 100 kg (220 lb)

Tire size:

Front: 25×8-12

Rear: 22×11-8

1. Excessive tire pressure (over 137.3 kPa (1.4 kg/cm², 19.9 psi)) may cause tire to burst. Inflate tires very slowly. Fast inflation could cause tire to burst.
2. Too low a pressure (below minimum tire pressure) will cause the rim to dislodge from the tire.
3. Put the same pressure in both rear tires. Uneven tire pressure will severely affect the handling.
4. Set tire pressures cold.

How to measure tire pressure

Use an appropriate low-pressure tire gauge. Set tire pressures to the following specifications:

Reference tire pressure:

Front:

22.6 kPa (0.23 kg/cm², 3.3 psi)

Rear:

16.7 kPa (0.17 kg/cm², 2.4 psi)

Minimum tire pressure:

Front:

20.6 kPa (0.21 kg/cm², 3.0 psi)

Rear:

14.7 kPa (0.15 kg/cm², 2.1 psi)

CAUTION:

Never use a tire pressure below minimum specification. The tire could separate from the wheel under severe operating conditions.

If the appropriate low-pressure tire gauge is not available, use the following temporary procedure:

Measure the circumference of the tire using an inelastic but flexible strip. Do not measure the tire's circumference on top of the tread blocks.

Standard tire circumference:

Front: 1,923 mm (75.7 in)

Rear: 1,745 mm (68.7 in)

Minimum tiure circumference:

Front: 1,917 mm (75.5 in)

Rear: 1,740 mm (68.5 in)

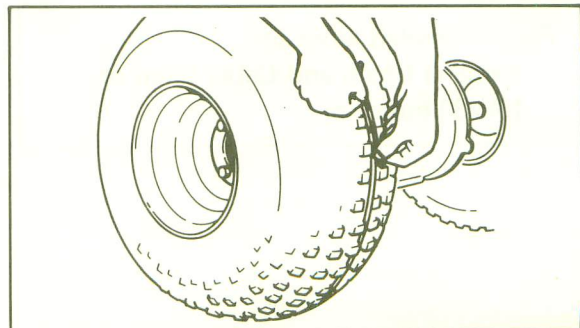

Tire wear limit

When the tire groove decreases to 3 mm (0.12 in) due to wear, replace the tire.

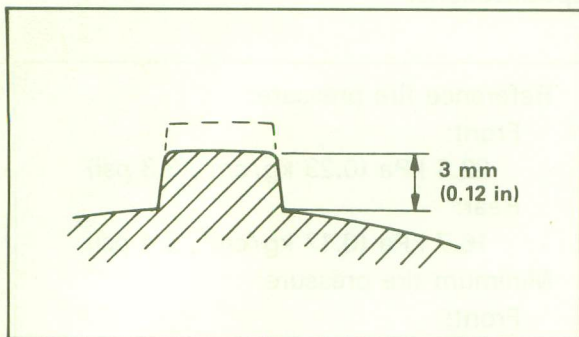

CAUTION:

Excessive tire wear will result from riding on paved surfaces.

Cable Inspection and Lubrication

1. Damage to the outer housing of the various cables may cause corrosion. Often free movement will be obstructed. An unsafe condition may result. Replace such cables as soon as possible.
2. If the inner cables do not operate smoothly, lubricate or replace them.

Recommended lubricant:
Yamaha Chain and Cable Lube or
10W30 motor oil

Brake and Change Pedals/Clutch and Brake Levers

Lubricate the pivoting parts of each lever and pedal.

Recommended lubricant:
Yamaha Chain and Cable Lube or
10W30 motor oil

Headlight Bulb Replacement

1. Disconnect rubber cap.
Turn the bulb holder counterclockwise and remove the defective bulb.

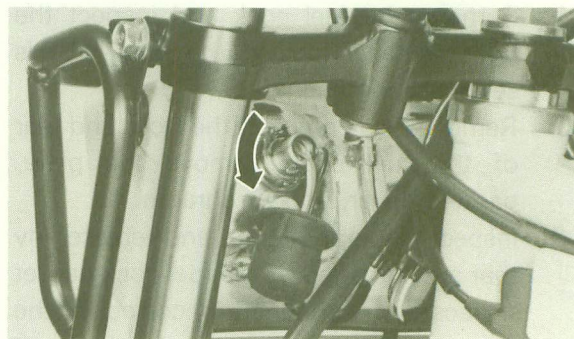

2. Slip a new bulb into position and secure it with the bulb holder.
3. Adjust the headlight unit if necessary.

Headlight Beam Adjustment

When necessary, adjust the headlight beam as follows:

1. Vertical adjustment
To adjust the beam to the upper, turn the adjusting screw clockwise.
To adjust the beam to the lower, turn the adjusting screw counterclockwise.

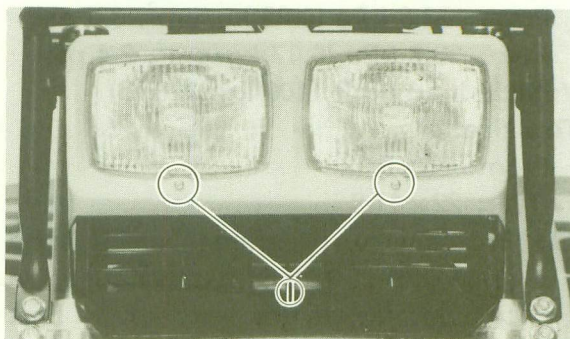

1. Vertical adjusting screw

3 ENGINE MAINTENANCE AND REPAIR

PREPARATION FOR SERVICE	3-1
CARBURETOR	3-2
Tuning	3-3
Tuning and Repair Parts	3-7
Main Jet Replacement	3-7
Removal	3-8
Inspection	3-8
Float Height	3-8
REED VALVE	3-9
Inspection	3-9
EXHAUST PIPE AND MUFFLER	3-10
Removal	3-10
Maintenance	3-10
CYLINDER HEAD	3-11
Removal	3-11
Maintenance	3-12
CYLINDER	3-13
Removal	3-13
Maintenance	3-13
PISTON	3-14
Removal	3-14
Maintenance	3-14
Piston Outside Diameter Measurement	3-15
Piston Rings	3-15
Piston Pin, Bearing	3-16
Assembly	3-16
CRANKCASE COVER	3-17
Removal	3-17
Assembly	3-17
WATER PUMP	3-18
Disassembly	3-18
Inspection	3-18
Assembly	3-18



KICK STARTER	3-19
Removal	3-20
Inspection	3-20
Assembly	3-20
CLUTCH	3-21
Removal	3-21
Maintenance	3-22
Installation	3-23
Mechanism Adjustment	3-24
SHIFTER	3-25
Removal	3-25
Inspection	3-25
Installation	3-25
ENGINE REMOVAL	3-26
ENGINE MOUNTING	3-27
CRANKCASE	3-27
Crankcase Disassembly	3-28
TRANSMISSION AND SHIFTER	3-29
Inspection	3-29
Bearing and Oil Seals	3-30
Transmission Installation	3-30
CRANKSHAFT	3-31
Inspection	3-32
Crankshaft Installation	3-32
COOLING SYSTEM	3-33
Radiator Removal	3-34
Thermostatic Valve Removal	3-34
Cooling System Checks	3-34

3 ENGINE MAINTENANCE AND REPAIR

PREPARATION FOR SERVICE

Prior to beginning any work on the engine, take note of the following bits of advice; they will greatly facilitate your engine maintenance and repair:

- Clean your machine as described in the General Information section entitled, "Cleaning and Storage";
- Group the parts of each component on individual trays, and arrange the parts in the order of their removal;
- When replacing parts, always use the genuine Yamaha article to maintain optimum performance, durability, and safety;
- All gaskets and seals should be replaced during engine work, and all gasket surfaces should be clean;
- During assembly, always apply oil or grease to bearing surfaces to protect them upon initial start-up;
- Replace all circlips which are distorted from use or disassembly;
- Always replace cotter pins and piston pin clips after one use;
- Always clean and oil the threads of nuts, bolts, and screws during assembly, and torque them to the proper specifications whenever possible.

CARBURETOR

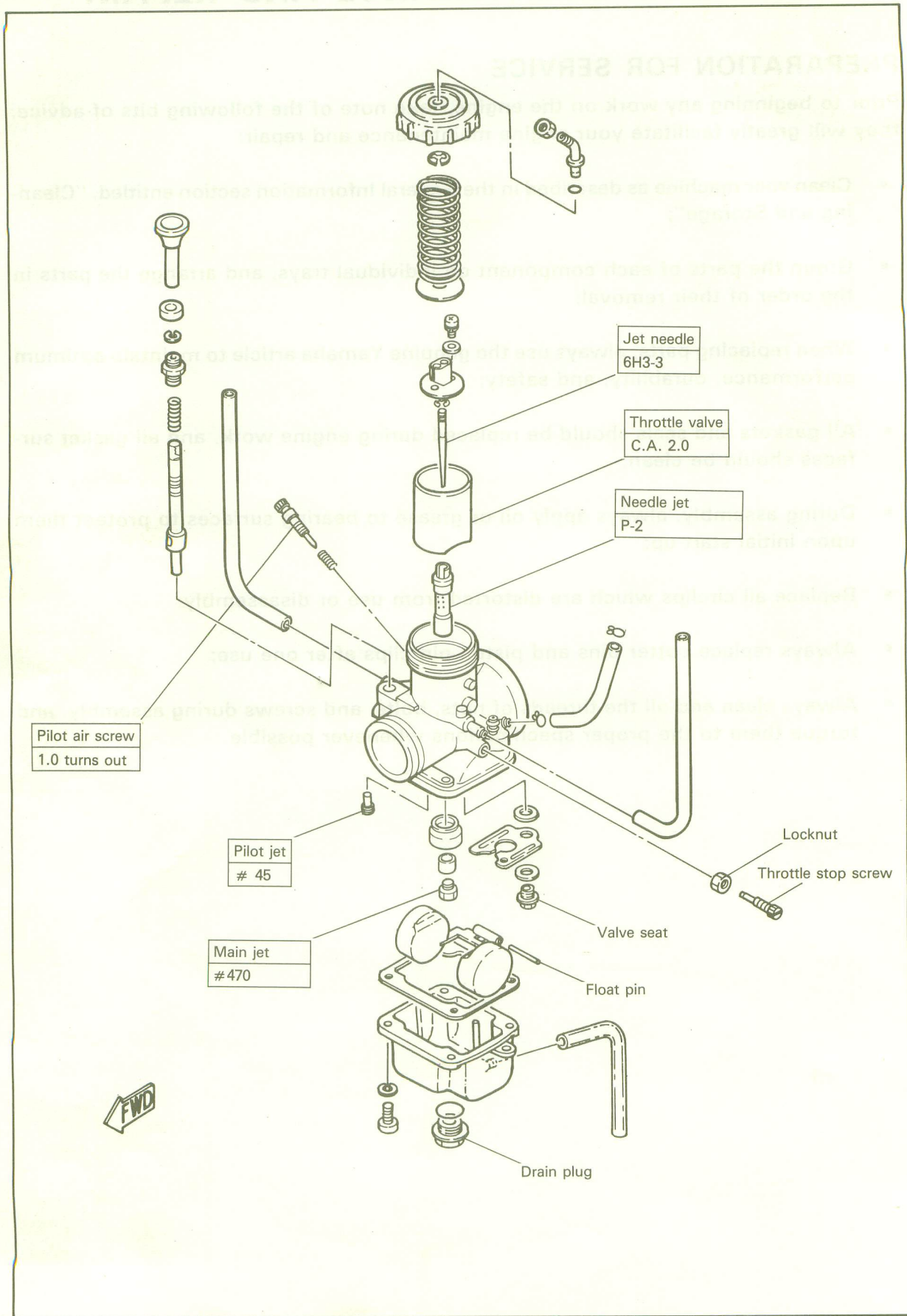

Tuning

Tuning a carburetor is not the mysterious science many racers believe it to be. One needs only to establish a basic knowledge of the identification and function of carb components as well as how they work together to do the job well.

Some basics

The carburetor mixes air and fuel to burn in the engine. To allow the engine to produce optimum power under a variety of conditions, the carburetor must provide the correct ratio of air and fuel at all times. To accomplish this, the carb has several overlapping systems, and each system has its greatest effect in a specific rpm range. Thus, the tuner can consider each general engine-speed range one at a time; he can then adjust the appropriate systems to achieve smooth, strong power delivery throughout the entire rpm range of the engine.

If a carburetor is in need of tuning, the engine usually is said to be "running too rich" or "running too lean." These terms refer to the amount of fuel relative to the volume of air being taken into the engine. Hence, an engine that is too rich needs less fuel for a given volume of air; conversely, an engine running too lean needs more fuel for the air being taken in.

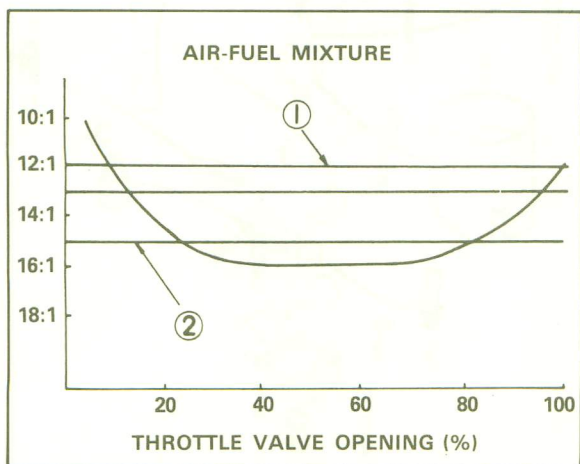

1. Maximum power mixture ratio
2. Theoretical mixture ratio

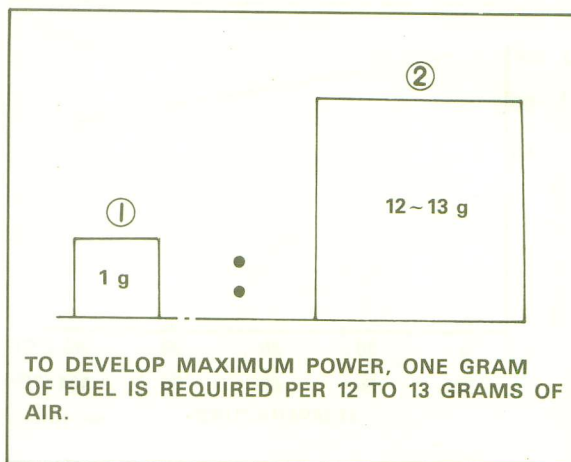

1. Fuel
2. Air

Tuning changes usually are required to accommodate changes in altitude. At higher altitudes, the air is "thinner" or less dense. This means there are fewer molecules of oxygen in a given volume of air to mix and burn with the fuel. The carb therefore needs to be made "leaner" to provide less gas and maintain the proper ratio of fuel to air at high altitudes.

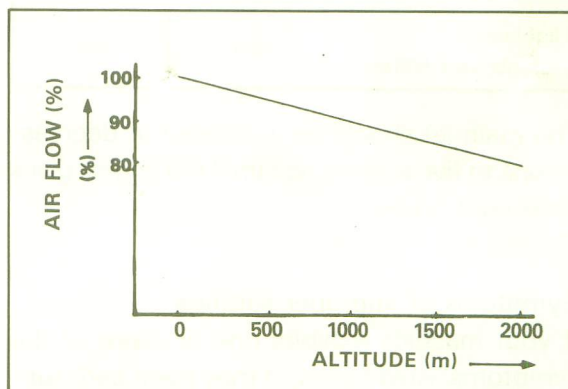

- Change due to elevation (at constant temperature).

If you race in an area with a wide range of temperatures, you might have to make carb adjustments for them. Higher air temperatures require leaner carb tuning. Higher humidity, on the other hand, demands carb settings which are richer. Such adjustments, however, should rarely be necessary for the majority of racers; motocross engines in general are sensitive only to the most extreme changes in such weather conditions.

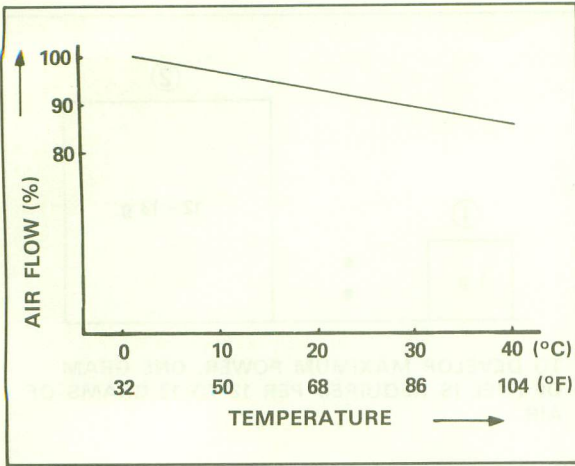

- Change due to temperature (at constant atmospheric pressure and humidity)

Condition	Mixture will be	Setting make
Cold air	lean	rich
Warm air	rich	lean
Dry air	lean	rich
Lowlands	Standard	
Highlands (Alt. above 1,500 m)	rich	lean

The main jet should be increased or decreased one to five sizes by test until the engine gives maximum power.

Symptoms of improper settings

If your machine exhibits one or more of the symptoms listed below, it may need carb tuning changes. Before attempting any changes, however, make sure that everything else is in good shape and tuned properly. Check the condition of the spark plug, make sure the *ignition timing* is correct, service the air filter properly, decarbonize the muffler and spark arrestor, etc. If your machine has run properly at a certain track in the past and then starts running poorly with the same carb settings, the problem is almost certain to be elsewhere; changing the carb settings in such a case would be a waste of time.

If your machine is too rich, it will:

- Accelerate poorly;
- Misfire;
- Smoke excessively;
- Foul spark plugs;
- Have a "deep" exhaust note.

If your machine is too lean, it will:

- Ping or rattle;
- Accelerate erratically;
- Act like it's running out of fuel;
- Run extremely hot.

- If your machine pings or rattles, make sure the gasoline you are using is fresh and of a sufficient octane rating. You might also try different brands of high-octane gas.

Making setting changes

Carb setting changes are made by changing or adjusting six carburetor components. The six components and their relative positions in the carb are shown in the illustration below.

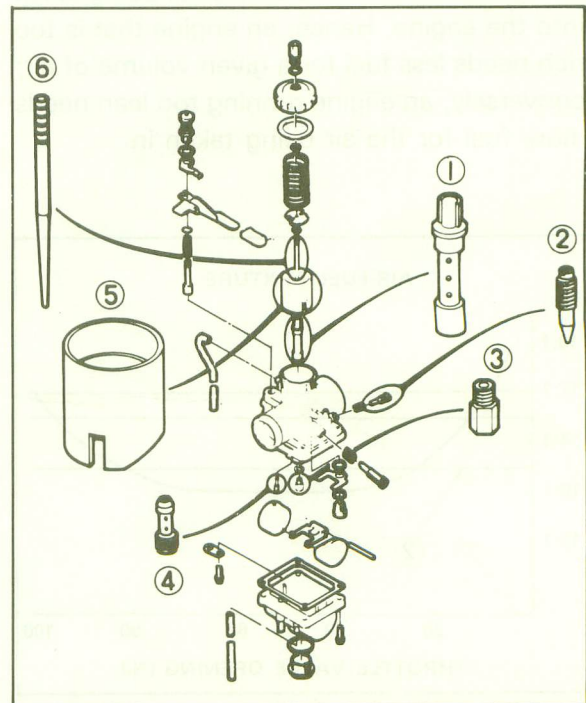

- | | |
|--------------------|-------------------|
| 1. Needle jet | 4. Pilot jet |
| 2. Pilot air screw | 5. Throttle valve |
| 3. Main jet | 6. Jet needle |

Four of the components, the jet needle, needle jet, main jet, and pilot jet, regulate the flow of fuel; the slide and pilot air screw regulate the flow of air. The following chart indicates the working range of each component. Note how the working ranges overlap each other as the throttle valve moves from closed to fully open.

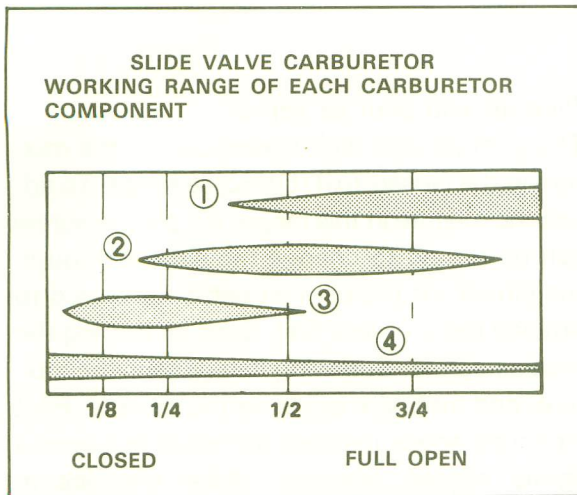

1. Main jet
2. Needle jet, jet needle
3. Throttle valve cutaway
4. Pilot air screw & jet

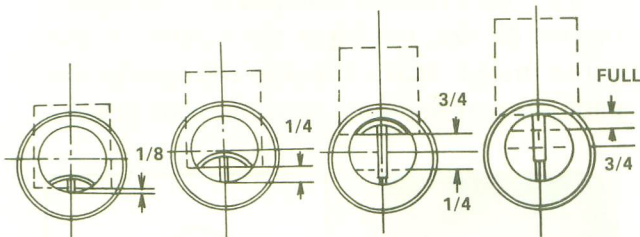

If you note a particular symptom of rich or lean running in a specific range, use the chart to determine which component needs changing. Use the following information to decide what changes to make.

Main jet

The main jet has its greatest effect in the 3/4-to-full-throttle range. The number of the main jet, stamped on the bottom or side of the jet, indicates the relative size of the hole in the jet which meters fuel. The larger the number on the main jet is, the bigger the hole and the

more fuel it will pass; hence, larger numbers mean richer jetting. Smaller numbers, of course, mean leaner jetting. Make main-jet changes one step at a time.

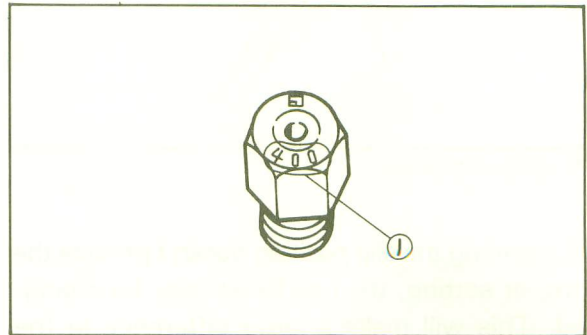

1. Jet number

Jet needle and needle jet

The jet needle and needle jet together have their greatest effect in the 1/4-to-3/4-throttle range. The needle moves in and out of the needle jet; since the needle is tapered, its position in the jet determines the amount of fuel allowed through. There are five grooves in the top of the needle in which a circlip fits. This clip locates the needle in the slide and, therefore, determines its position relative to the needle jet. Moving the clip down has the effect of pulling the needle further out of the jet; the mixture is thereby richened. Moving the clip up leans the mixture. Change the clip position one step at a time.

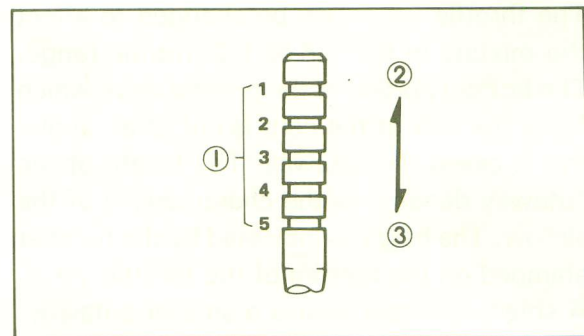

1. Clip position
2. Leaner
3. Richer

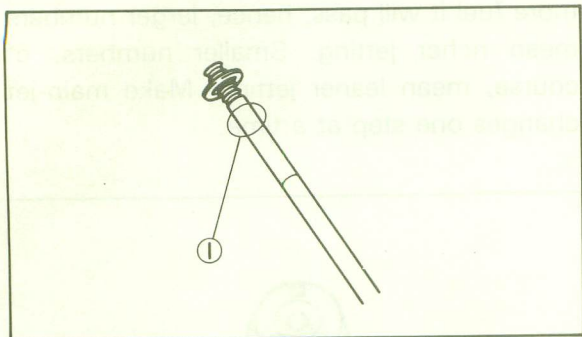

1. Jet needle number

If changing the clip position doesn't provide the proper setting, the needle jet may be changed. This will make a large difference in the amount of fuel provided. On the side of the needle jet are stamped two figures, a letter followed by an even number; these figures indicate the relative size of the needle jet. The letter ranges from "N" (leaner) to "Q" (richer). The number will stand for one of five sizes within each letter's range. The smaller the number is, the leaner the needle jet. Change the needle jet one step at a time, and make fine adjustments with the jet needle clip.

When changing the Jet Needle for the standard Needle Jet, the jet needle length must be proper so that it will not slip off the needle jet at full throttle operation. (If the jet needle slips off, the machine may become uncontrollable.)

Throttle valve

The throttle valve may be changed to affect the mixture in the 1/8-to-1/2-throttle range. The bottom portion of the throttle valve which faces the rear of the carb is cut at an angle; this is called the cutaway. The height of the cutaway determines the characteristic of the airflow. The height is indicated by the number stamped on the bottom of the throttle valve. A smaller number means a smaller cutaway, and a smaller cutaway provides a richer mixture. Conversely, a larger cutaway makes the mixture leaner. Make throttle valve changes in increments of 0.5.

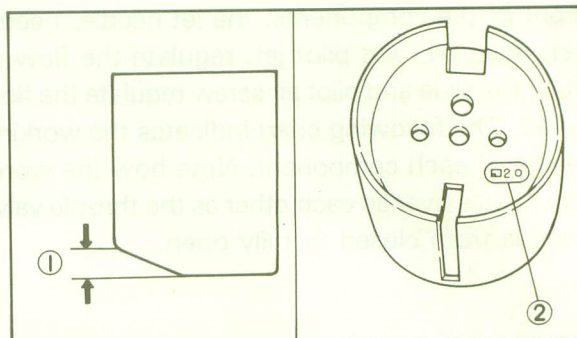

1. Cutaway

2. Slide number

Pilot jet and pilot air screw

The pilot jet and pilot screw control the mixture in the closed-to-1/8-throttle range. To adjust the mixture in this range, the pilot air screw can be turned to change the airflow through the circuit, or the pilot jet can be changed to provide more or less fuel. Start by turning the pilot air screw. Screwing it in richens the mixture, and turning it out leans the mixture. Pilot air screw specs indicate the turns out from a lightly seated position. Make changes in 1/2-turn increments. If turning the screw between one and two-and-a-half turns doesn't provide the desired results, change the pilot jet. This jet has a number stamped on it which indicates its size; the larger the number is, the richer the jet. Make one-step changes in the pilot jet, and fine-tune with the pilot screw.

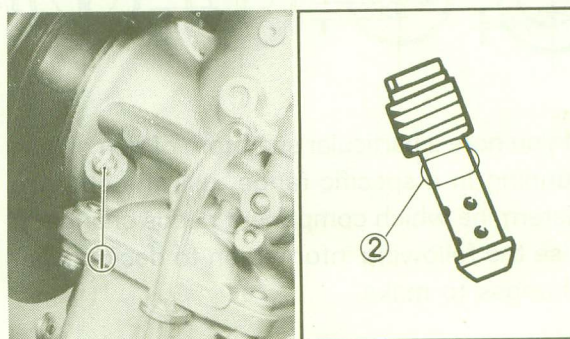

1. Pilot air screw

2. Pilot jet number

Test runs

Warm up the engine with the carburetor at the standard settings, and run two or three laps of the course while examining the operating condition of the spark plug.

Test-ride the machine by varying the throttle opening.

Condition of spark plug	
Correct	Insulator is dry and light tan color.
Too hot	Insulator is whitish.
Too cold	Insulator is wet and sooty.

If spark plug is whitish, the fuel-air mixture is lean.

- Replace the main jet with a one step large type.

If spark plug is wet, the fuel-air mixture is rich.

- Replace the main jet with a one step smaller type.
- Set the carburetor so that the engine delivers satisfactory power at any throttle opening.

If the air-fuel mixture is too lean, the engine tends to overheat and seize up, and on the contrary, if too rich, the spark plug easily gets wet, thus causing misfires.

The proper strength of the mixture varies depending on atmospheric conditions (pressure, humidity, and temperature).

Taking these conditions into consideration, adjust the carburetor settings properly.

- Take a note of carburetor settings as well as weather conditions, course conditions, and lap times so they can be utilized as reference data for future races.

Tuning and Repair Parts

Part name	Size	Part number
Main jet	# 450	137-14143-90
	# 460	137-14143-92
	(STD) # 470	137-14143-94
	# 480	137-14143-96
	# 490	137-14143-98
Pilot jet	(STD) # 45	193-14142-45
Needle jet	(STD) P-2	38W-14141-42
Valve seat assembly	φ3.3	239-14190-00
	(STD)	

Main Jet Replacement

NOTE:

It is not necessary to remove the carburetor to replace the main jet: Loosen the hose clamps on the manifold and air cleaner joint, rotate the carb, and remove the drain plug from the float bowl. The main jet can thereby be removed and replaced.

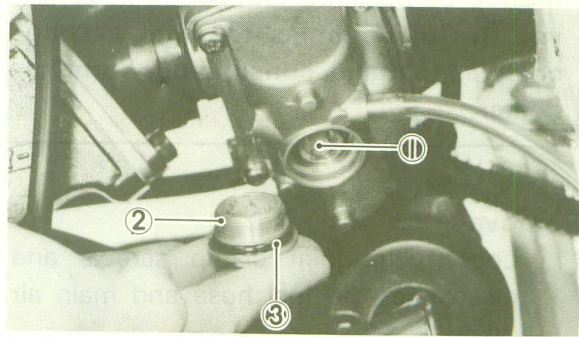

1. Main jet 2. Drain plug 3. O-ring

Standard main jet size:
470

WARNING

When the drain plug is removed, the fuel in the float bowl will drain. Do not remove the plug when the engine is hot. Place a rag under the carb when removing the plug to catch the fuel. Remove the plug in a well-ventilated area, away from any open flame. Always clean and dry the machine after completing main jet changes.

IMPORTANT:

The carburetor has been set for operation at or near sea level; in most instances, it will not require changes. Some conditions, however, do demand carb setting changes to maintain performance. If this is the case, make the changes in small increments and check the results with a spark plug check. Improper settings can lead to poor performance or possible engine damage. If you are in doubt as to what setting changes to make, consult your Yamaha dealer.

Removal

1. Loosen the joint clamp screws and disconnect the fuel hose and main air hose.

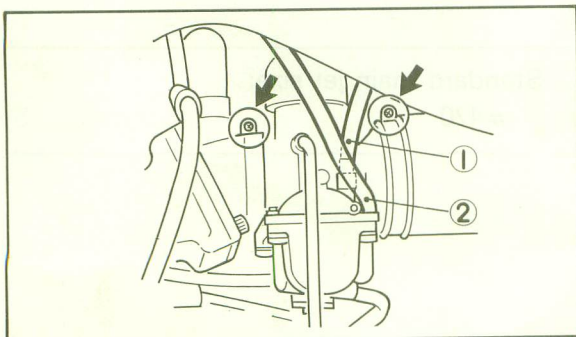

1. Fuel hose 2. Main air hose

Inspection

1. Examine carburetor body and fuel passages. If contaminated, wash carburetor in petroleum-based solvent. Do not use caustic carburetor cleaning solutions. Blow out all passages and jets with compressed air.
2. Examine condition of floats. If floats are damaged, they should be replaced.
3. Inspect inlet float valve and seat for wear or contamination. Replace these components as a set.

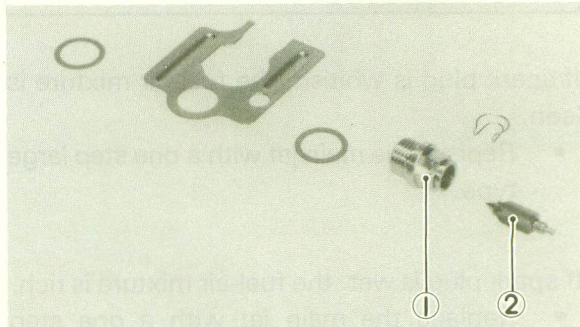

1. Valve seat 2. Float valve

Float Height

Hold the carburetor in an upside down position. Incline the carburetor at $60^{\circ} \sim 70^{\circ}$ (so that the end of the float valve does not hang down of float weight), and measure the distance from the mating surface of the float chamber (gasket removed) to the top of the using a gauge.

Float height:

31.3 ± 1.0 mm (1.23 ± 0.04 in)

Level with carburetor base

CAUTION:

Check the float valve and valve seat for wear before adjustment.

Make the adjustment by bending the tang on the float arm.

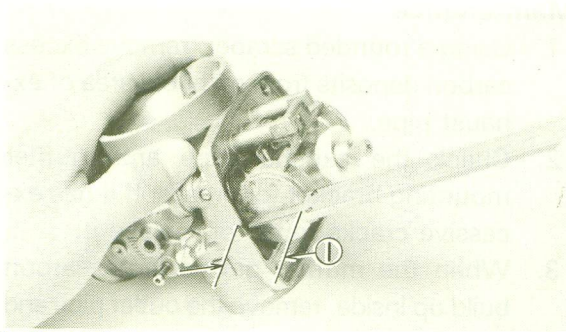

1. Float height

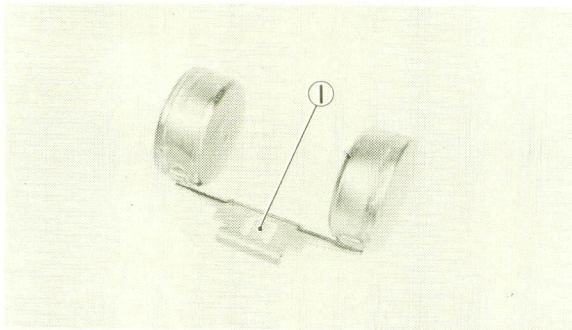

1. Tang

REED VALVE

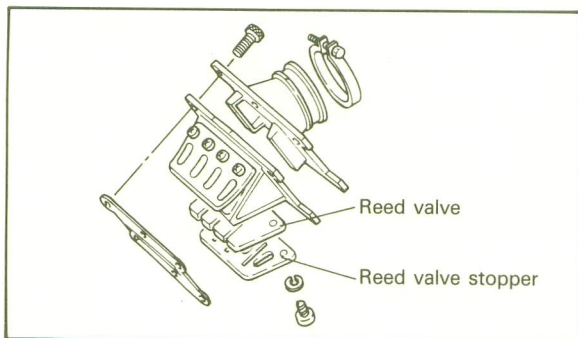

Inspection

1. Inspect rubber intake manifold for signs of weathering, checking or other deterioration.
2. Inspect reed valves for signs of fatigue and cracks. Reed valves should fit flush or nearly flush against neoprene seats. If in doubt as to sealing ability, apply suction to carburetor side of assembly. Leakage should be slight to moderate.
3. Check valve stopper height. If beyond tolerance, adjust or replace.

Valve stopper height:
 12 ± 0.2 mm (0.47 ± 0.008 in)

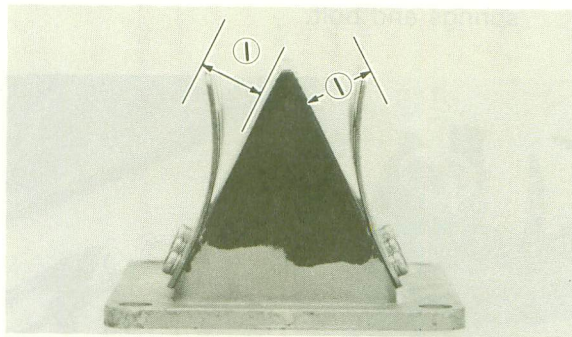

1. Valve stopper height

If it is 0.3 mm (0.012 in) more or less than specified, replace the valve stopper.

4. Check reed valve for bending. If beyond tolerance, replace reed valve.

Reed valve bending limit:
 0.6 mm (0.022 in)

5. During reassembly, note the cut in the lower corner of the reed and stopper plate.

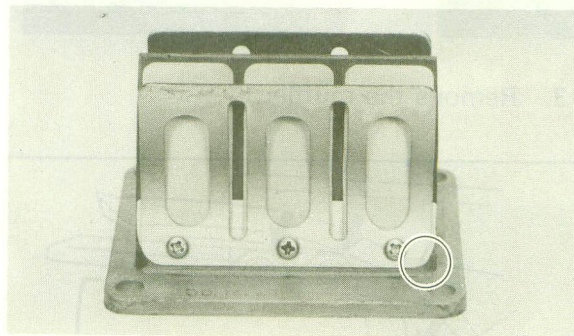

EXHAUST PIPE AND MUFFLER

Removal

1. Remove the exhaust pipe mounting springs and bolt.

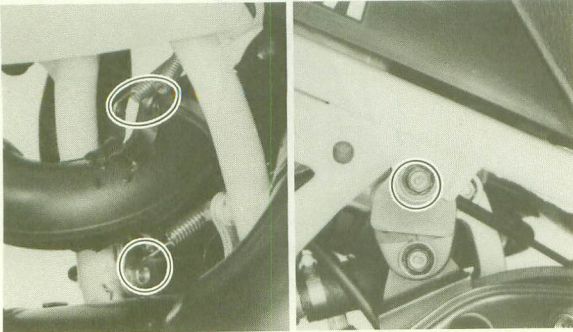

2. Loosen the joint screw and remove the exhaust pipe.

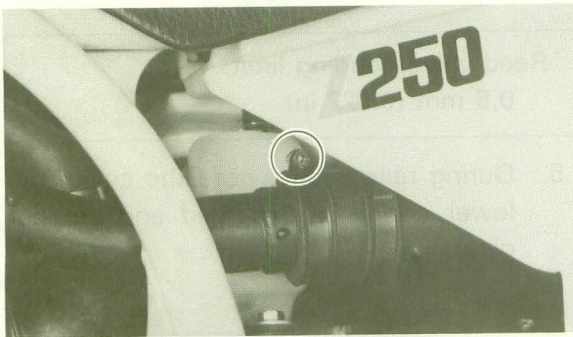

3. Remove the muffler.

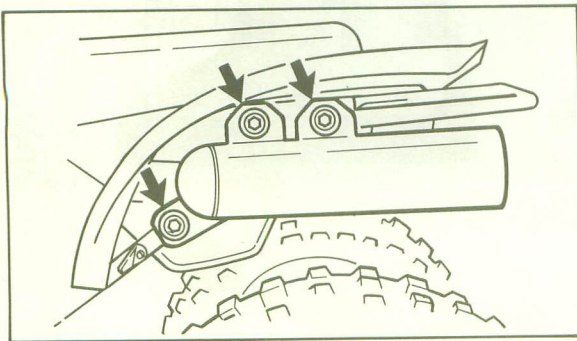

Maintenance

1. Using a rounded scraper, remove excess carbon deposits from manifold area of exhaust pipe.
2. Check the exhaust pipe and muffler mounting bracket for cracks. If it has excessive cracks repair or replace it.
3. When the muffler gets a large carbon build up inside, remove the outlet pipe and decarbonize.

CYLINDER HEAD

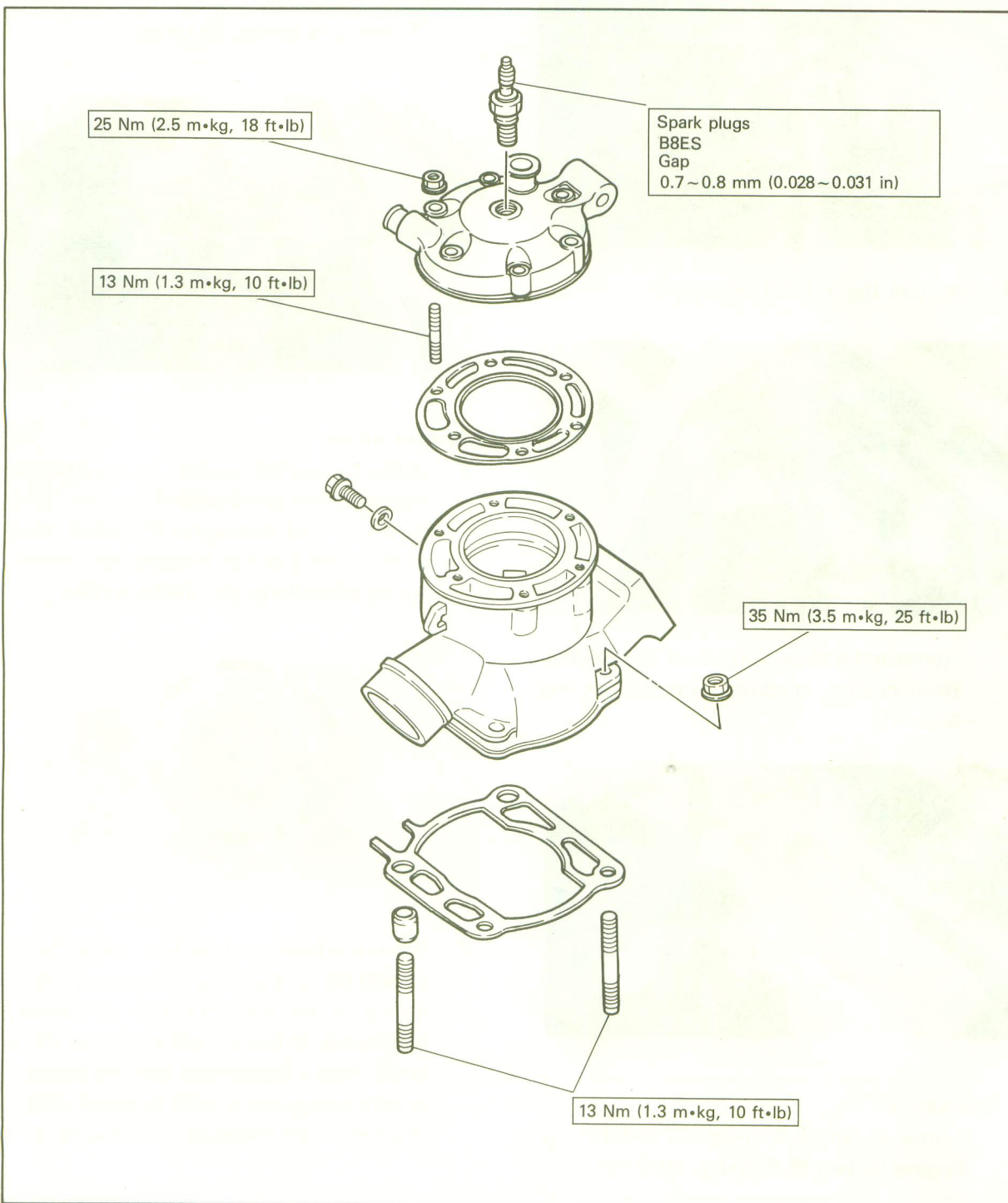

Removal

NOTE: _____
Before servicing the engine (disassembling of the cylinder head, cylinder, and clutch), thoroughly drain the coolant.

1. Drain the transmission oil.

2. Drain off the coolant from the cooling system. (See, paragraph "Coolant draining".)
3. Remove the spark plug lead wire and spark plug.
Disconnect radiator hoses at cylinder head.

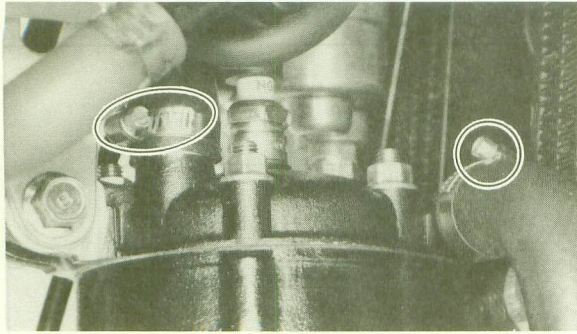

4. Remove the Y.E.I.S. chamber.

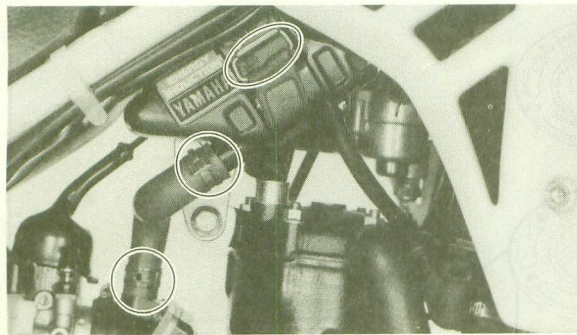

5. Remove the three bolts from the cylinder head holding brackets, and remove the brackets.

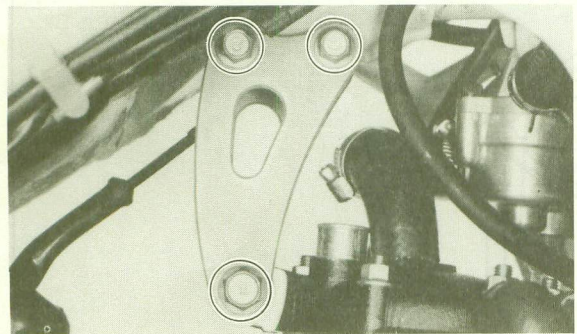

Bracket to:

Frame 30 Nm (3.0 m•kg, 22 ft•lb)
 Engine 55 Nm (5.5 m•kg, 40 ft•lb)

6. Loosen the six cylinder head nuts a quarter turn each in a crisscross pattern, then remove the cylinder head nuts in the same pattern.
 Remove the cylinder head and head gasket. And discard it.

Cylinder head nut:
 25 Nm (2.5 m•kg, 18 ft•lb)

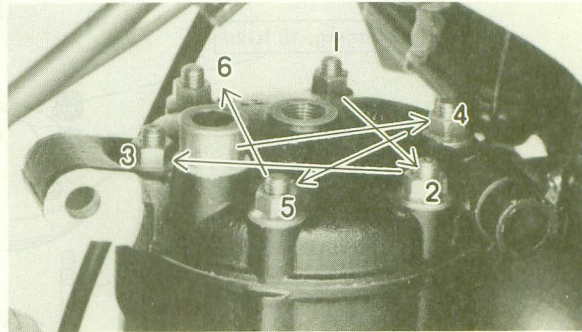

Maintenance

1. Using a rounded scraper, remove carbon deposits from combustion chamber. Take care to avoid damaging the spark plug threads. Do not use a sharp instrument. Avoid scratching the metal surface.

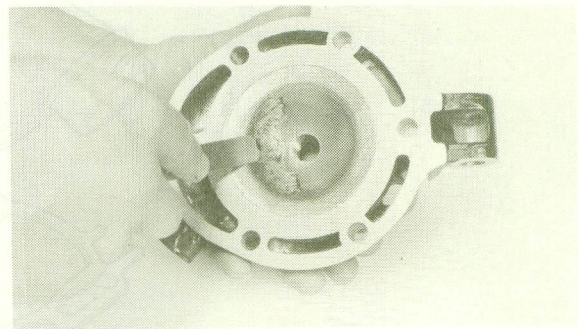

2. Place the head on a surface plate. There should be no warpage. Correct by resurfacing. Place 400~600 grit wet emery sandpaper on surface plate and resurface head using a figure-eight sanding pattern. Rotate head several times to avoid removing too much material from one side.

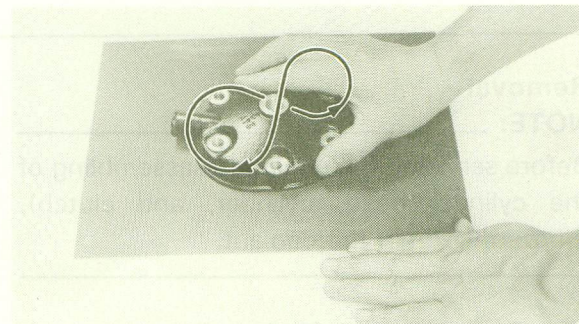

CYLINDER

Removal

1. Remove the exhaust pipe.
2. Remove the cylinder head.
3. Remove the carburetor assembly.

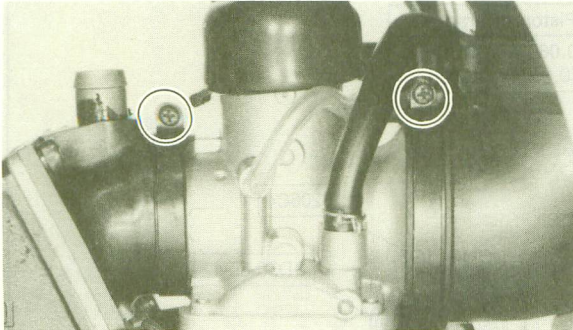

4. Disconnect the C.D.I magneto lead from the clamp and remove the cylinder holding nuts and cylinder.

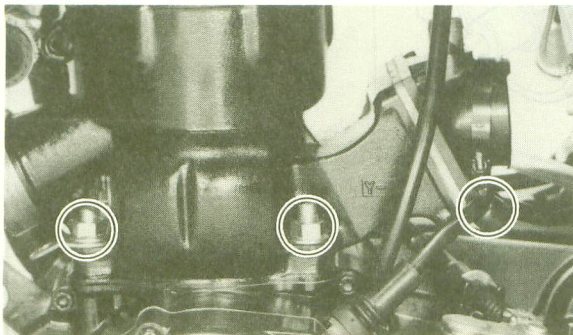

Cylinder holding nut:
35 Nm (3.5 m•kg, 25 ft •lb)

5. With the piston at top dead center, raise the cylinder just enough to stuff a clean shop towel into the crankcase around the connecting rod; this will prevent dirt from entering the crankcase. Remove the cylinder and base gasket and discard the gasket.

Maintenance

1. Using a rounded scraper, remove carbon deposits from the exhaust port.
2. Check cylinder bore. Using a cylinder hone, remove any scoring. Hone lightly, using smooth stones. Hone no more than required to avoid excess piston clearance.
3. Using a cylinder gauge set to standard bore size, measure the cylinder. Measure front-to-rear and side-to-side at top, center and bottom just above exhaust port.

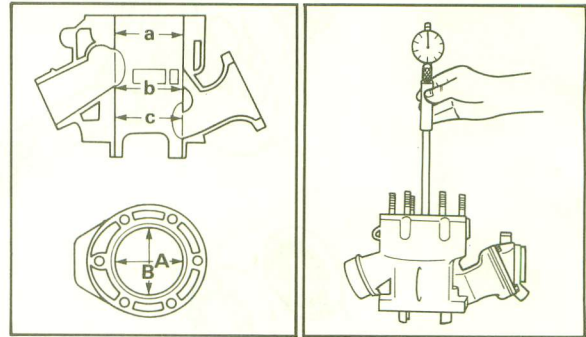

4. Compare minimum and maximum measurements. If over tolerance and not correctable by honing, rebore to next oversize.

Max. allowable taper:
0.05 mm (0.0020 in)
Max. allowable out-of-round:
0.01 mm (0.0005 in)

PISTON

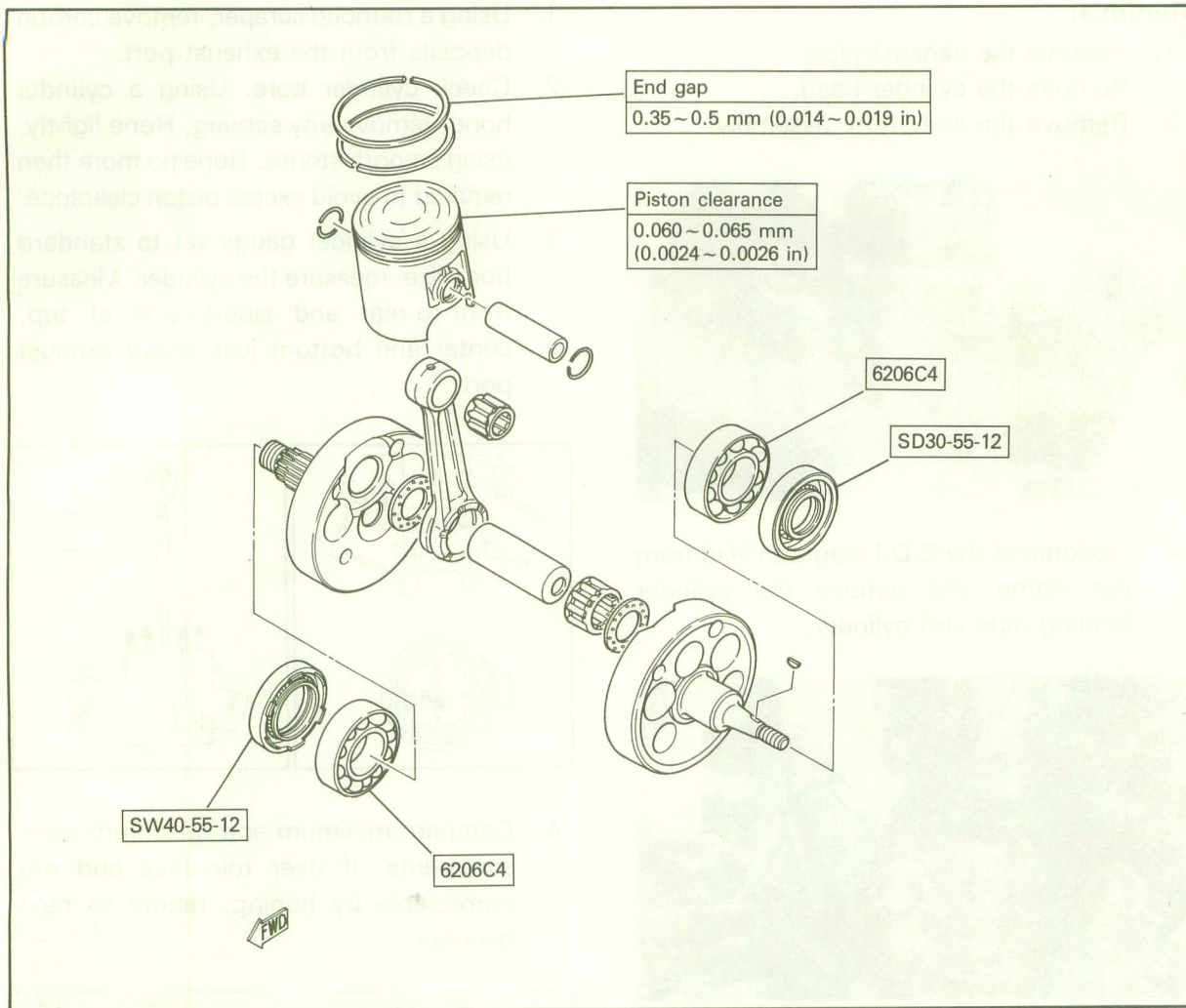

Removal

1. Remove the piston pin clip ① from the piston. Push the piston pin out from opposite side. Remove the piston.

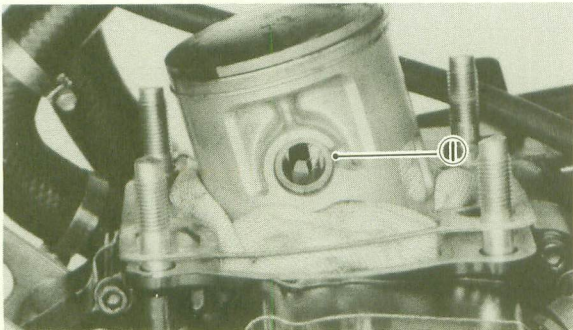

1. Piston pin clip

NOTE:

If the pin hangs up, use a piston pin puller. Do not hammer on pin as damage to rod, piston and bearing will result.

Maintenance

1. Using a rounded scraper, remove carbon deposits from piston crown and ring grooves.

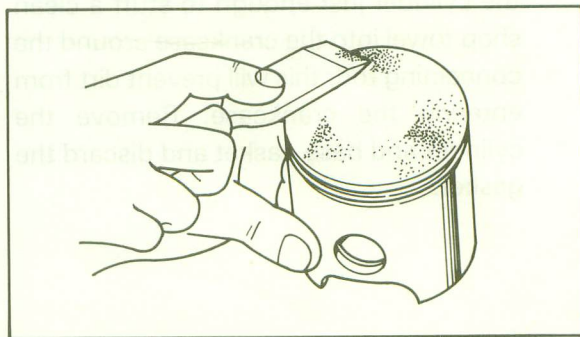

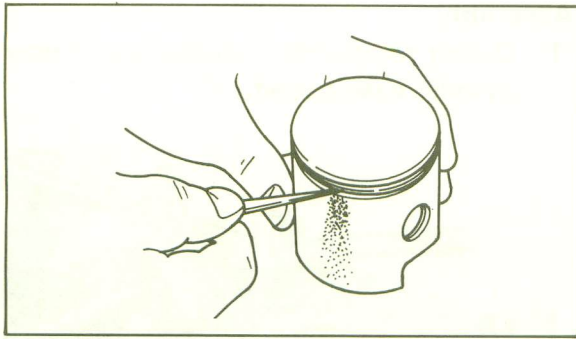

- Using 400~600 grit wet sandpaper, lightly sand score marks and lacquer deposits from sides of piston. Sand in crisscross pattern. Do not sand excessively.

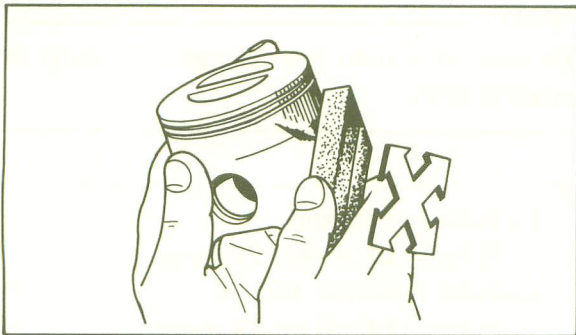

Piston Outside Diameter Measurement

- To measure a cutaway piston, measure across the skirts at height "H" (just above the intake skirt cutaway) as shown in illustrations 1 and 2. Record this partial measurement.

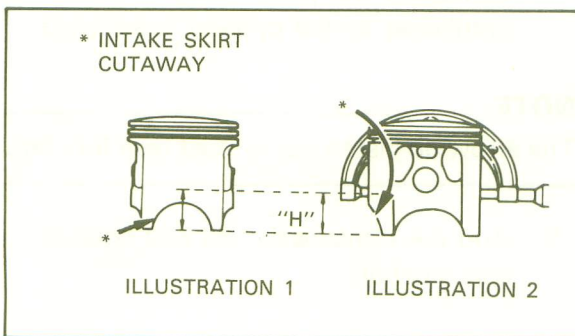

- Add to this Partial Measurement (PM) the Adjustment Amount (AA) in the following table (PP + AA = piston diameter). The result will be the piston diameter. Use this figure to compute piston-to-cylinder clearance.

HEIGHT "H"	ADJUSTMENT AMOUNT (AA)
31 mm (1.22 in)	0 mm (0 in)

- To determine the piston-to-cylinder clearance, subtract the piston diameter from the minimum cylinder diameter. If the nominal piston clearance is not within tolerance, replace the piston or bore the cylinder as required.

PISTON CLEARANCE =

Minimum Cylinder diameter — Maximum Piston diameter

$$68.020 \text{ mm (2.678 in)} - 67.960 \text{ mm (2.675 in)} = 0.060 \text{ mm (0.002 in)}$$

Std piston clearance

0.060 ~ 0.065 mm (0.0024 ~ 0.0026 in)

Piston Rings

- Insert ring into cylinder. Push down approximately 20 mm (0.787 in) using piston crown to maintain right-angle to bore. Measure installed end gap. If beyond tolerance, replace.

Ring end gap installed

0.35 ~ 0.50 mm (0.014 ~ 0.02 in)

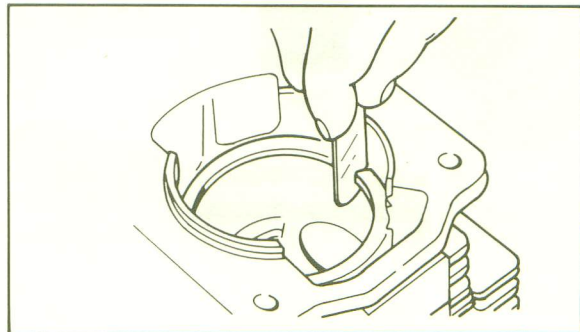

2. Holding cylinder towards light, check for full seating of ring around bore. If not fully seated, check cylinder. If cylinder is not out-of-round, replace piston ring.
3. During installation, make sure ring ends are properly fitted around ring locating pin in piston groove. Apply liberal coating of two-stroke oil to ring.

NOTE: _____

New ring requires break-in. Follow first portion of new machine break-in procedure.

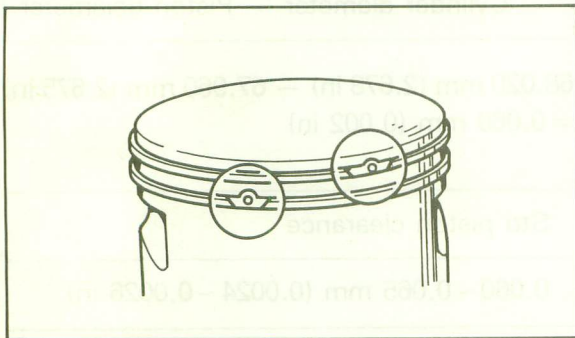

Piston Pin, Bearing

1. Check the pin for signs of wear. If any wear is evident, replace pin and bearing.
2. Check the pin and bearing for signs of heat discoloration. If excessive (heavily blued), replace both.
3. Check the bearing cage for excessive wear. Check the rollers for signs of flat spots. If found, replace pin and bearing.

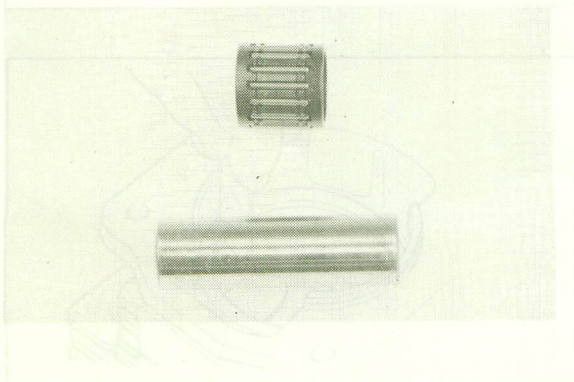

Assembly

1. During re-assembly, always use a new cylinder base gasket.

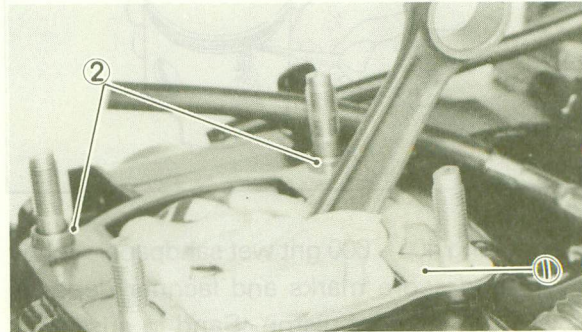

1. Base gasket 2. Dowel

NOTE: _____

Be sure to tighten the cylinder head nuts to specification.

Cylinder nut torque:

35 Nm (3.5 m•kg, 25 ft•lb)

Cylinder head nut torque:

25 Nm (2.5 m•kg, 18 ft•lb)

2. During re-assembly, coat the piston skirt areas liberally with two-stroke oil.
3. Install new piston pin circlips and make sure they are fully seated within their grooves.
4. Take care during installation to avoid damaging the piston skirts against the crankcase as the cylinder is installed.

NOTE: _____

The arrow on piston dome must face forward.

5. Add the transmission oil and coolant to specification.

CRANKCASE COVER

Removal

1. Drain off the transmission oil and coolant. Loosen the hose clamp and disconnect the coolant hoses.

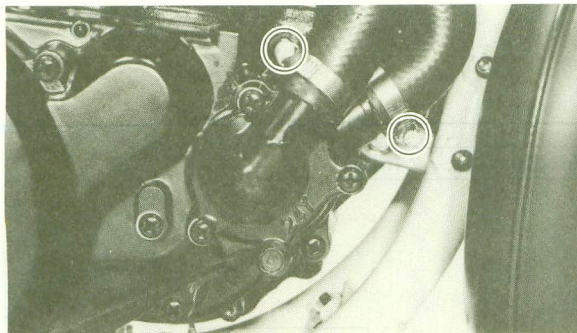

2. Remove the rear brake and footrest assembly.
3. Remove the kickstart lever and cover.

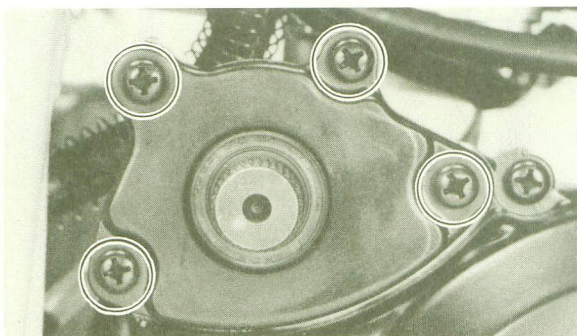

4. Remove the right hand crankcase cover.

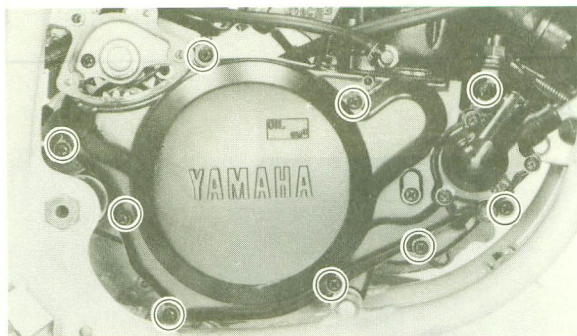

Assembly

For reassembly, reverse the procedure for disassembly while taking the following care:

1. Install the dowels, new gasket, and crankcase cover.

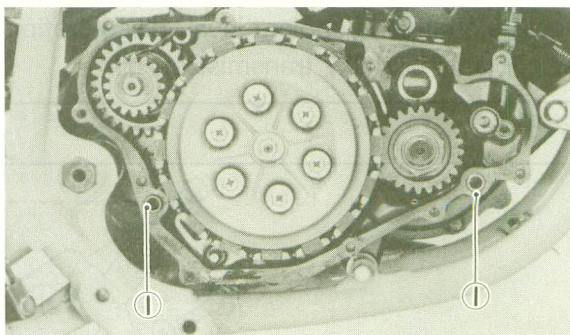

1. Dowel

2. Tighten the following components.

Crankcase cover: 10 Nm (1.0 m•kg, 7.2 ft•lb) Footrest bracket: 55 Nm (5.5 m•kg, 40 ft•ib)
--

WATER PUMP

Disassembly

NOTE:

It is necessary to disassemble the water pump, unless there is no abnormality such as excessive change in coolant level, discoloration of coolant, or milky transmission oil.

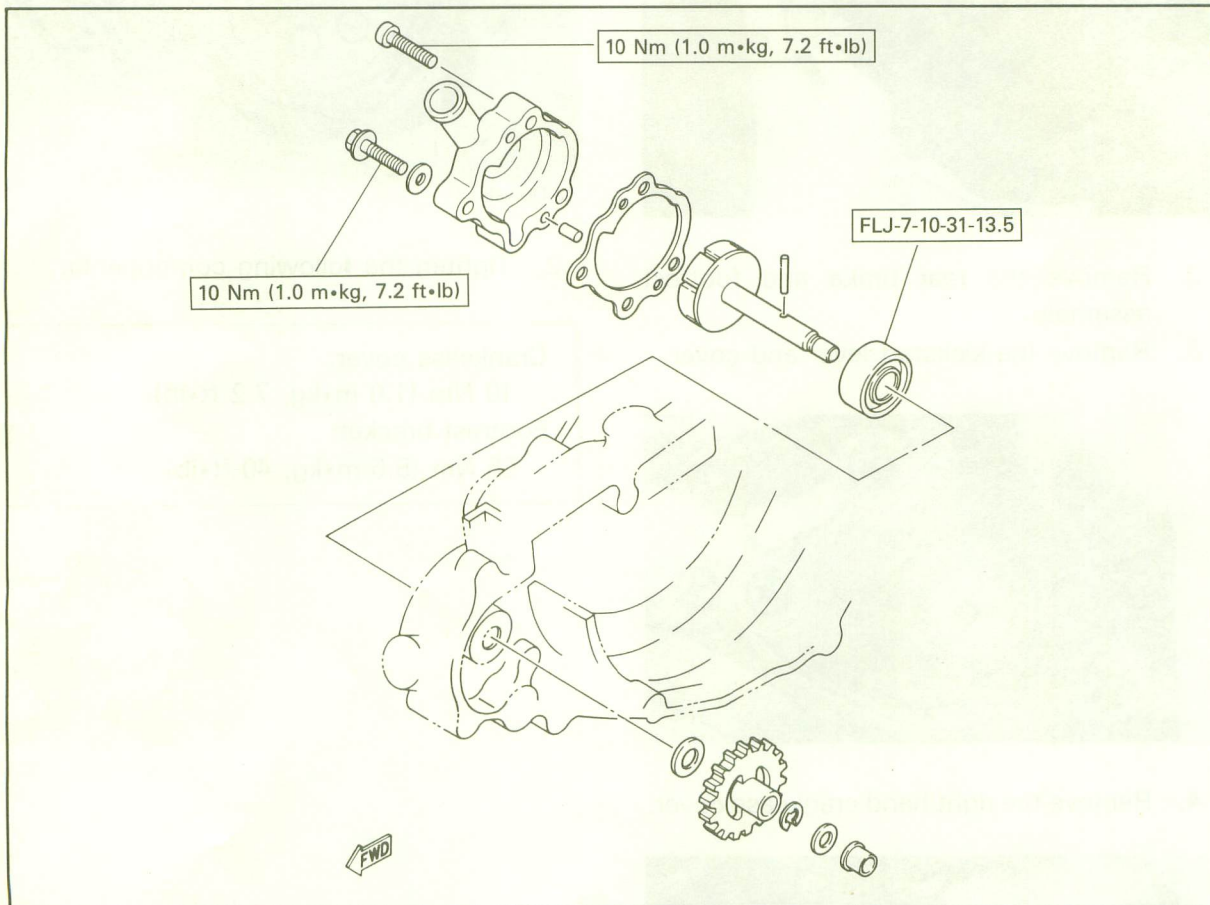

Inspection

1. Remove the deposits from the impeller and water pump housing.
2. Check the impeller for cracks and damage. Replace if necessary.
3. Check for wear of the impeller, and replace it as required.
4. Check the oil seal and bearing for damage and wear. If damaged or worn excessively, replace the oil seal and bearing as a set.

NOTE:

When installing the oil seal, make sure the "WATER SIDE" mark is on the outside.

Assembly

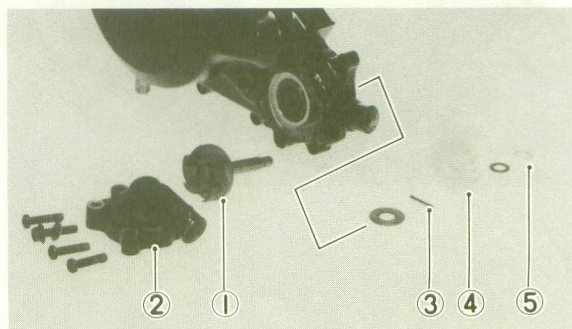

1. Pump housing
2. Impeller shaft
3. Pin

4. Driven sprocket
5. Circlip

For reassembly, reverse the procedure for disassembly while taking the following care:

1. When installing the impeller shaft, apply a grease to oil seal and impeller shaft. And install the shaft while turning it.

NOTE: _____

Take care so that the oil seal lip is not damaged or the spring does not slip off its position.

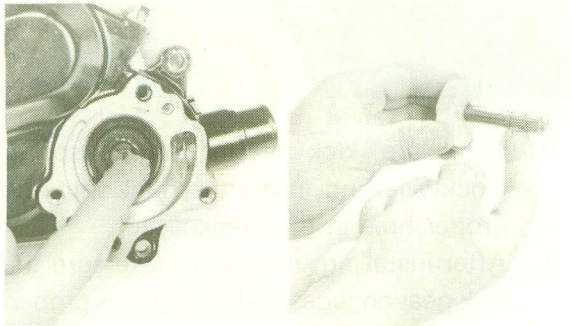
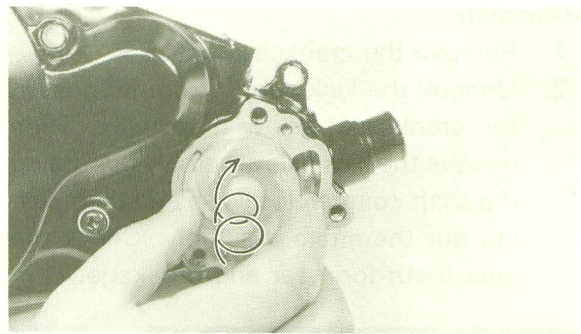

KICK STARTER

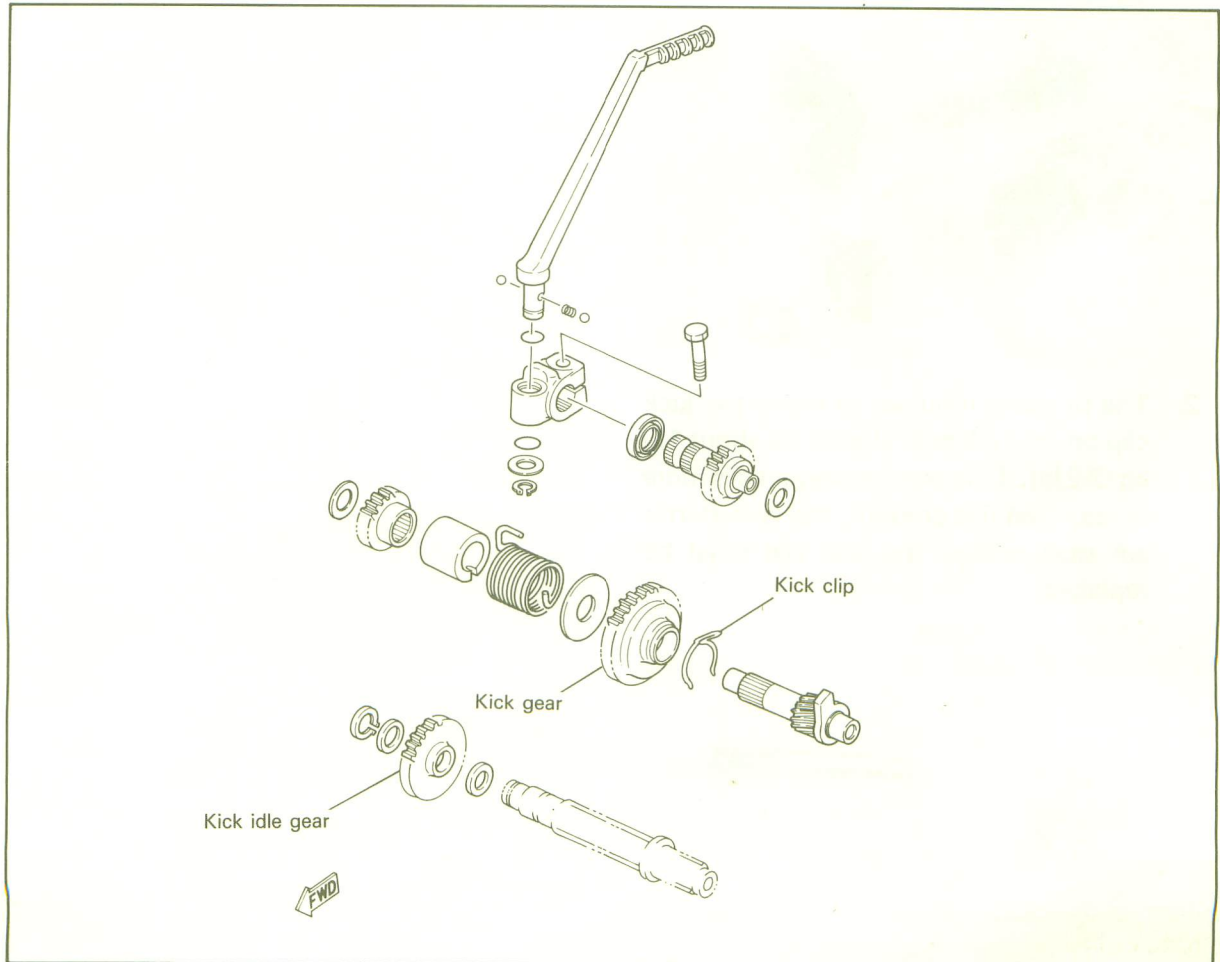

Removal

1. Remove the crankcase cover.
2. Unhook the kick spring from its post in the crankcase. Allow it to relax. Then remove the kick axle assembly by rotating the shaft counterclockwise and then pulling out the entire assembly. Check the gear teeth for wear and breakage.

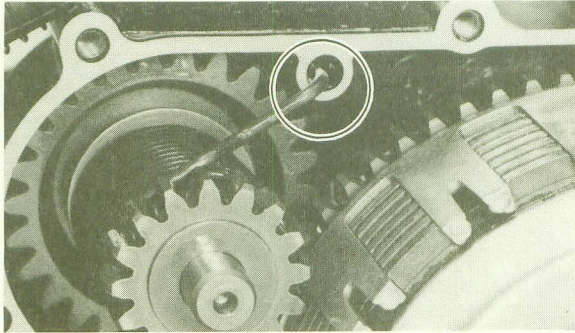

Inspection

1. Inspect the teeth of the idle and kick gears for wear or damage, replace the gear if wear or damage is found.

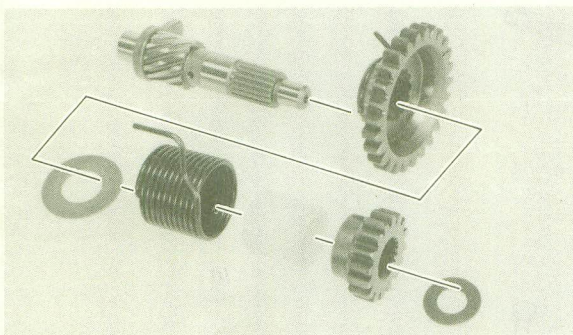

2. The pressure required to move the kick clip on the kick gear should be about 1.0 kg (2.2 lb). If the pressure required is more or less than this amount, the kick starter will malfunction; the kick clip must be replaced.

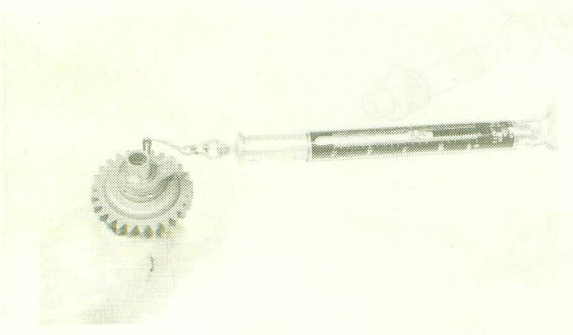

Assembly

1. Slide the shaft into the case; make sure the kick clip fits into its groove in the crankcase.

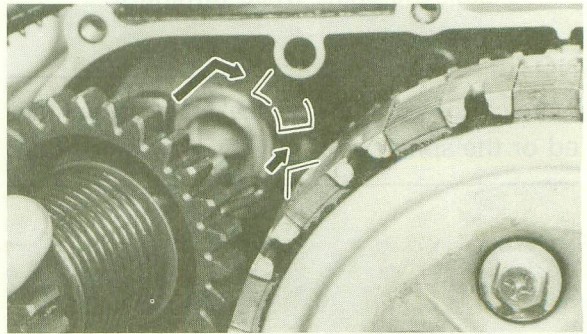

2. Turn the kick starter return spring clockwise and insert the hook into the proper hole in the crankcase.
3. After installing, check to make sure the kick gear engages and disengages properly with the idle gear.

CLUTCH

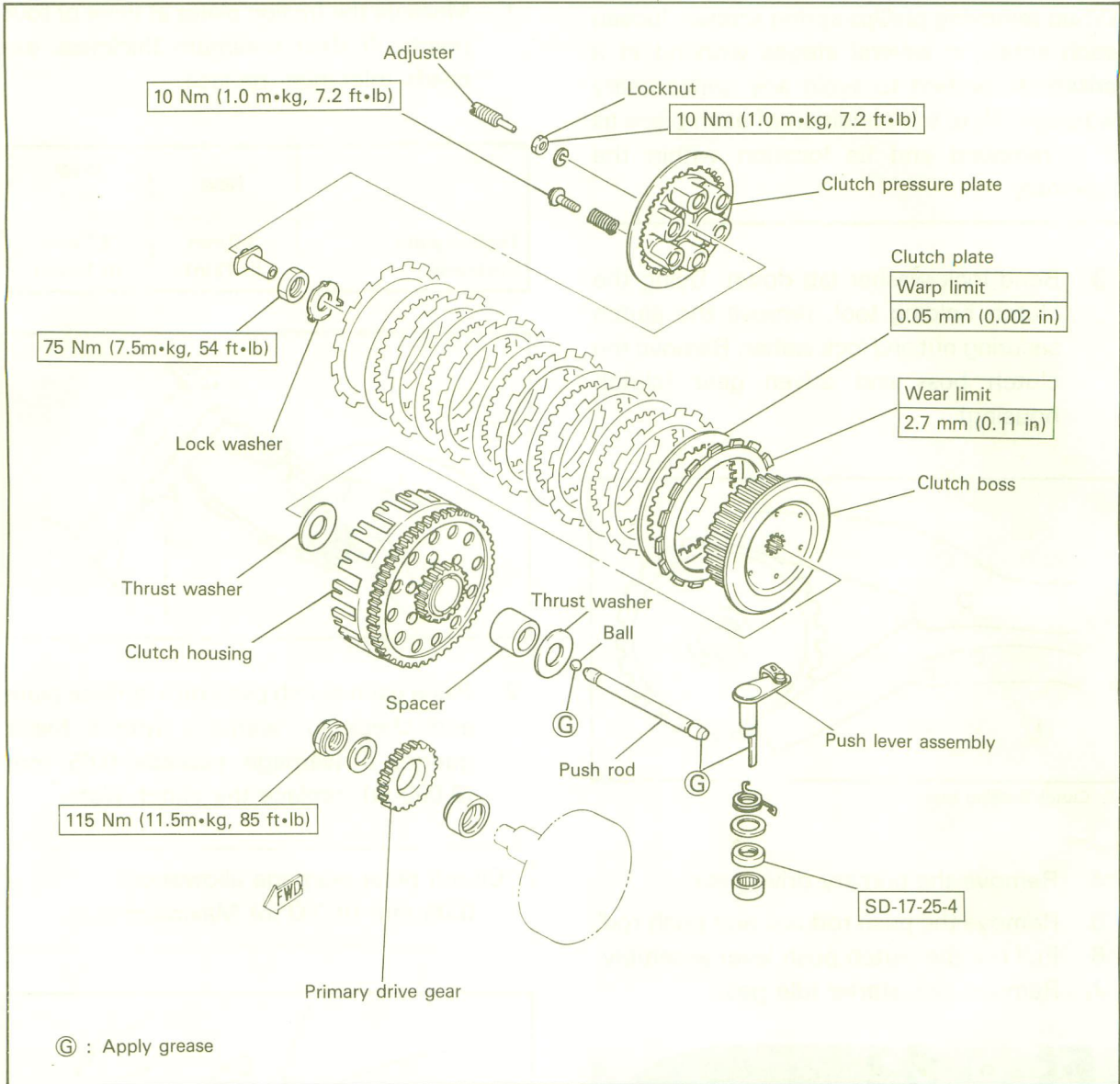

Removal

1. Loosen the primary drive gear nut.

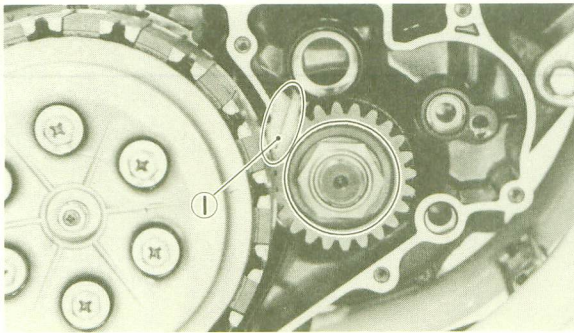

NOTE:

Place a piece of rolled rug ① or lead between primary drive gears.

2. Remove the phillips screws (6) holding the pressure plate. Remove the clutch springs, pressure plate and push rod. Remove the clutch plates and friction plates.

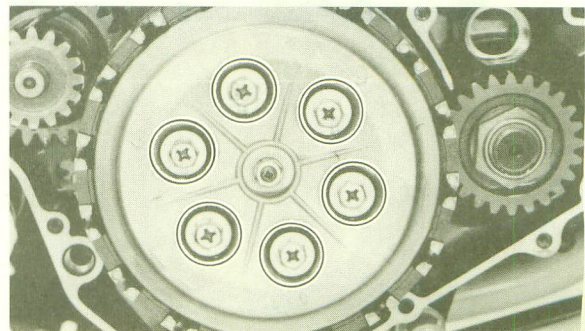

NOTE: _____

When removing phillips spring screws, loosen each screw in several stages working in a crisscross pattern to avoid any unnecessary warpage. Note the condition of each piece as it is removed and its location within the assembly.

3. Bend lock washer tab down. Using the clutch holding tool, remove the clutch securing nut and lock washer. Remove the clutch boss and driven gear (clutch housing).

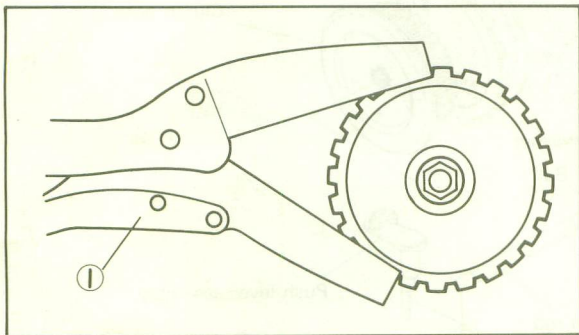

1. Clutch holding tool

4. Remove the primary drive gear.
5. Remove the push rod ball and push rod.
6. Pull out the clutch push lever assembly.
7. Remove kick starter idle gear.

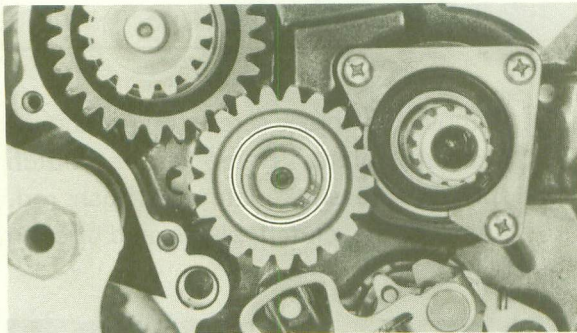

Maintenance

1. Measure the friction plates at three or four points. If their minimum thickness exceeds tolerance, replace.

	New	Wear limit
Friction plate thickness	3.0 mm (0.12 in)	2.7 mm (0.106 in)

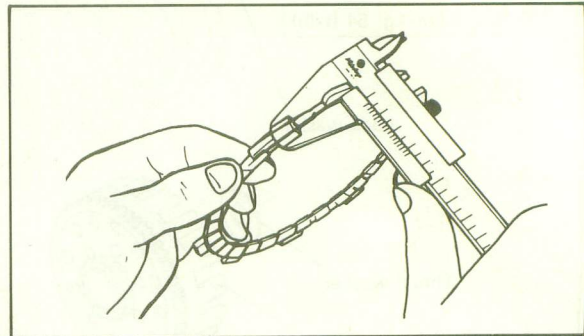

2. Place each clutch plate on a surface plate and check for warpage with a feeler gauge; if warpage exceeds 0.05 mm (0.002 in), replace the clutch plate.

Clutch plate warpage allowance:
0.05 mm (0.002 in) Maximum

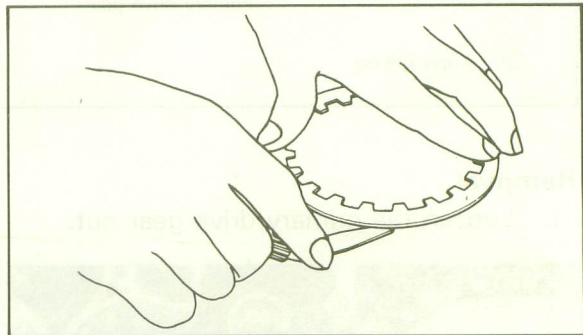

3. Inspect the clutch hub and the outer clutch for wear as shown; if the wear is excessive, replace the component.

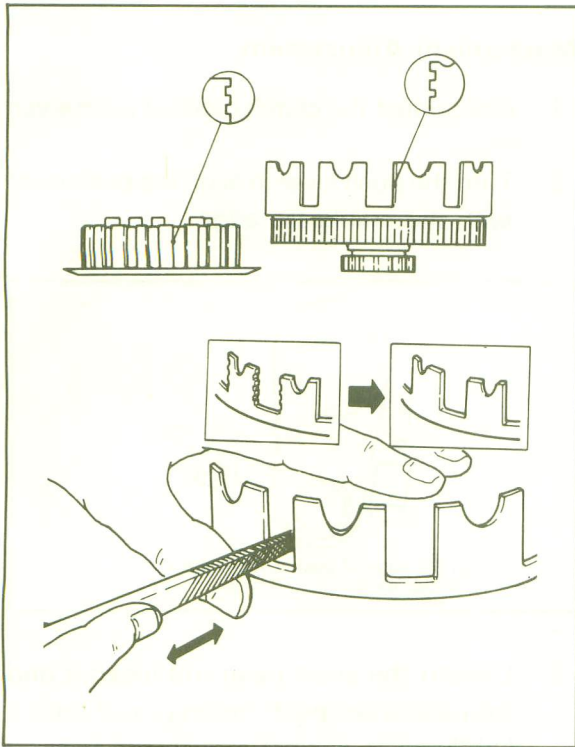

4. Measure each clutch spring; if the free length of a spring is less than 33.9 mm (1.33 in), replace the spring as a set.

	New	Min.
Clutch spring free length	34.9 mm (1.37 in)	33.9 mm (1.33 in)

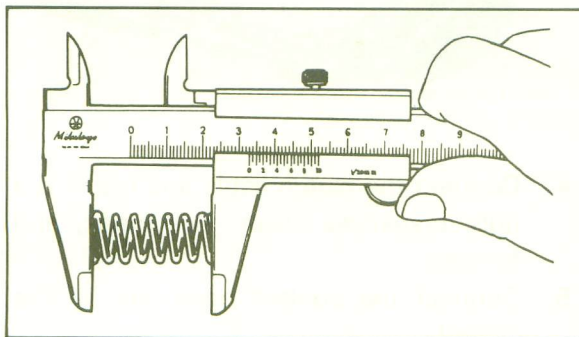

5. Roll the push rod across a surface plate. If rod is bent, replace.

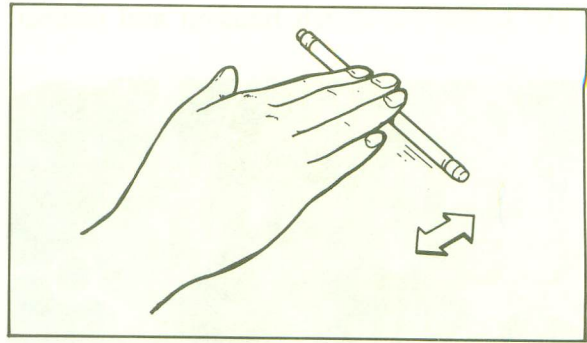

6. Inspect the clutch push lever. If excessively worn, repair using 300 ~ 400 grit sandpaper or replace.

Installation

Reverse the removal procedure while taking the following care:

1. Install the kick starter idle gear.

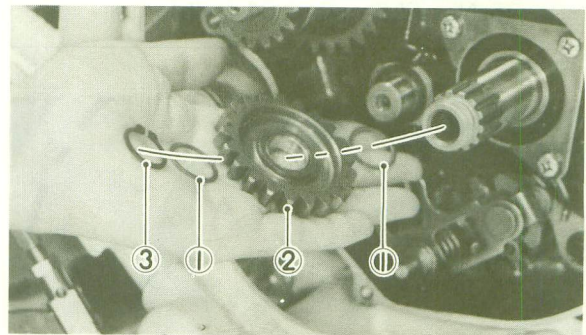

1. Washer
2. Idle gear
3. Circlip

2. Install the primary drive gear and washer.

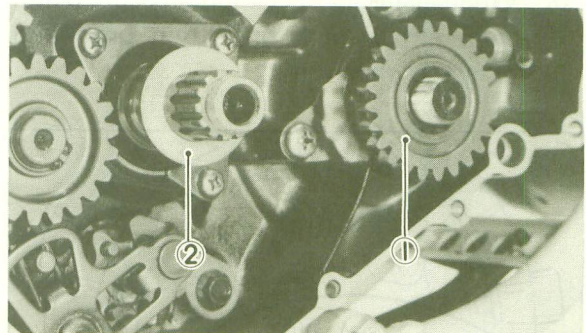

1. Drive gear
2. Washer

3. Install the clutch housing and washer.

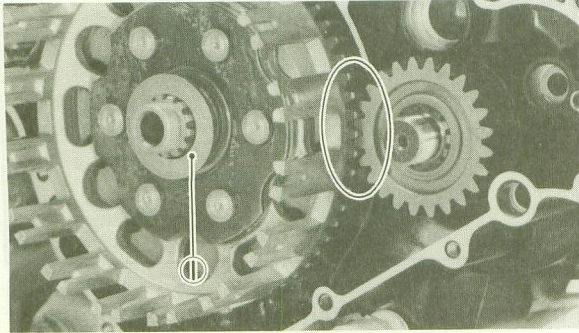

1. Washer

4. When installing the clutch locknut, always use a new lock washer. After tightening the locknut to the specification, be sure to lock it with the lock washer.

Clutch locknut torque:
75 Nm (7.5 m•kg, 54 ft•lb)

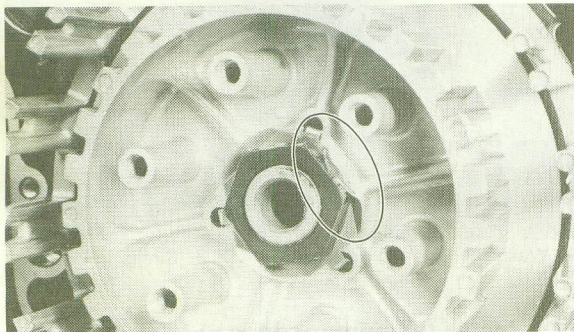

5. When installing the clutch pressure plate, align arrow mark on clutch boss and pressure plate mark.

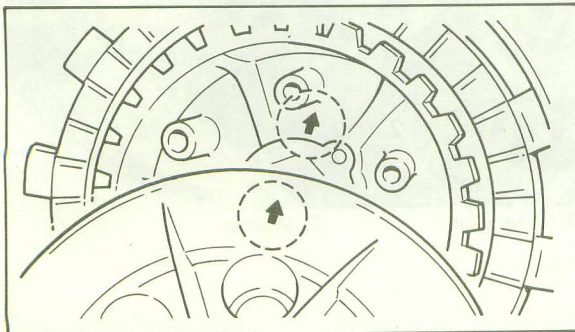

6. Tighten the drive gear nut.

Primary drive gear nut torque:
115 Nm (11.5 m•kg, 85 ft•lb)

Mechanism Adjustment

1. Disconnect the clutch cable at push lever end.
2. Turn the push lever to align the push lever with the crankcase edge.

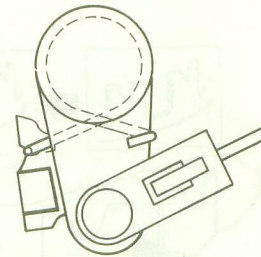

Align the edge of push lever to the crankcase edge.

3. Loosen the short push rod locknut and turn the short push rod in or out until it lightly seats against a push rod ball. Tighten the locknut.

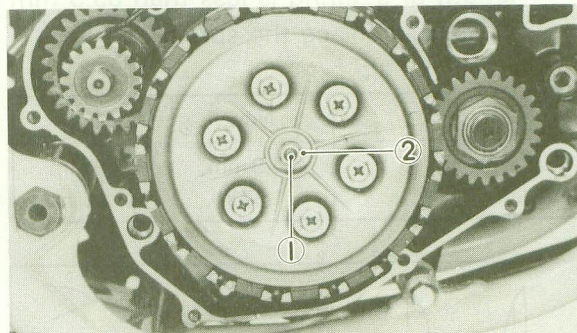

1. Short push rod 2. Locknut

4. Connect the clutch cable and install the right crankcase cover, kick crank, and footrest.
5. Connect the coolant hose and fill the coolant.
6. Add oil through the oil filler hole.

SHIFTER

NOTE:

Shifter maintenance should be performed with clutch assembly removed.

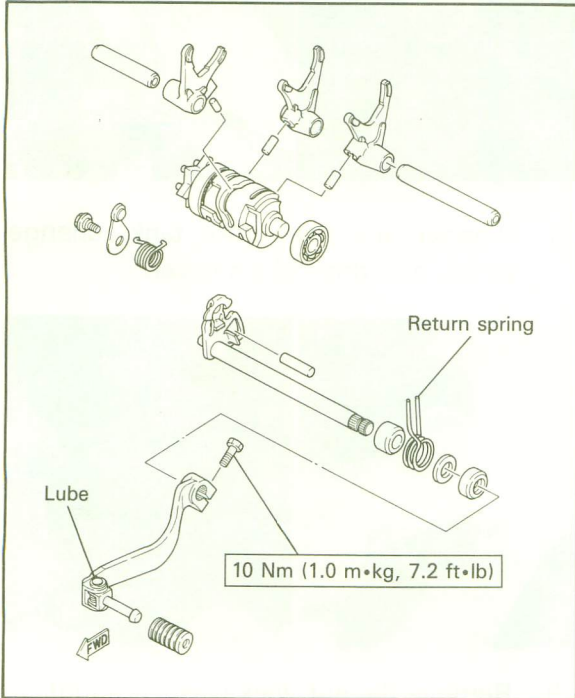

Removal

1. Pull out the change lever assembly.
2. Remove the flange bolt, stopper lever and spring.

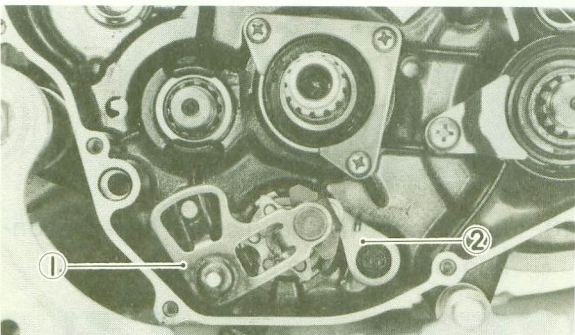

1. Change lever assembly

2. Stopper lever

Inspection

1. Inspect shift return spring. A broken or worn spring will impair the return action of the shifting mechanism.
2. Inspect change lever assembly for bending of shaft, worn or bent spline, and broken or worn shift arm spring. A bent shaft will cause hard shifting.

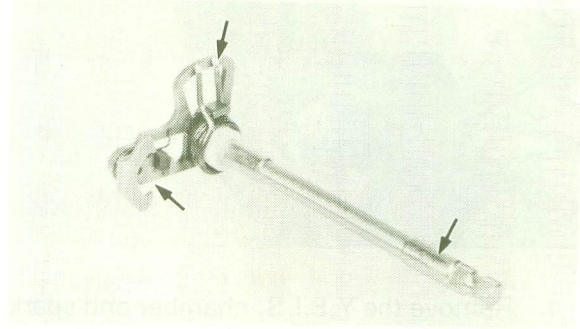

3. Inspect the segment for wear or damage, replace as required.

Installation

1. Engage the shift return spring with its home position.

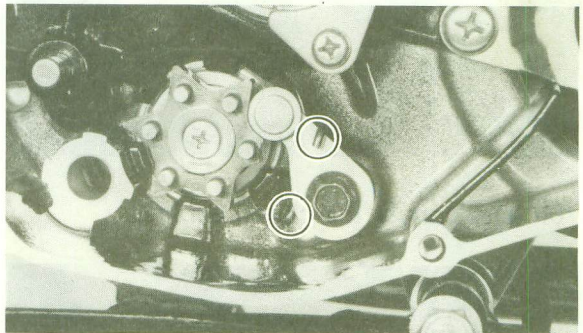

ENGINE REMOVAL

1. Drain the coolant and transmission oil.
2. Remove the exhaust pipe and footrest assembly.
3. Remove the side cover and coolant hoses.

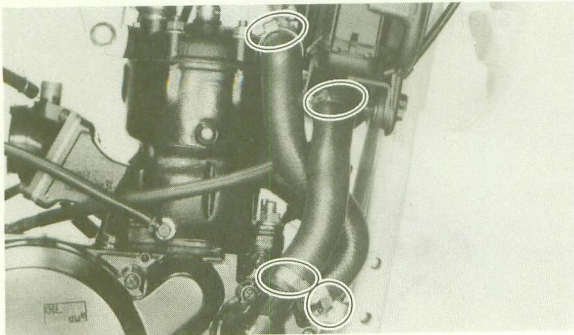

4. Remove the Y.E.I.S. chamber and spark plug lead.
5. Remove the cylinder head holding brackets and coolant hose.

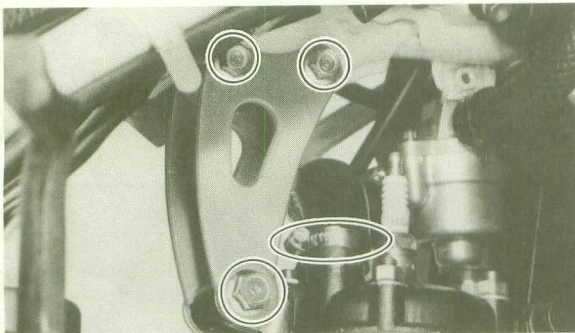

6. Disconnect the clutch cable.

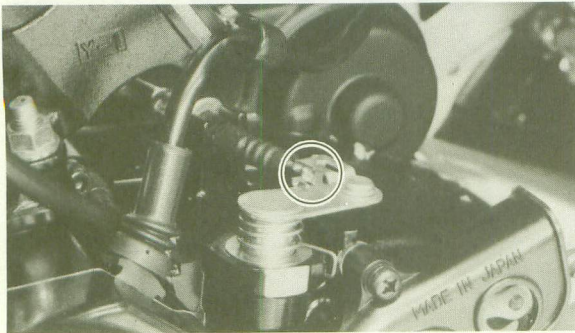

7. Disconnect fuel pump suction hose and C.D.I. leads.

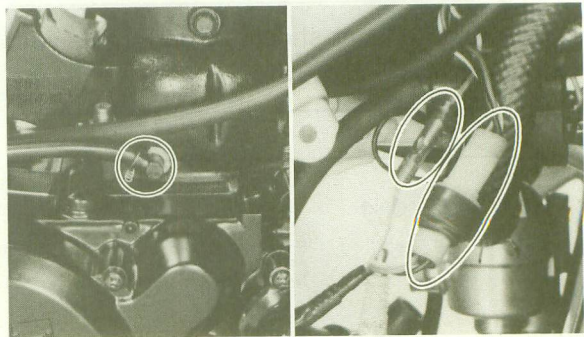

8. Remove the rear brake tank, change pedal, and drive chain cover.

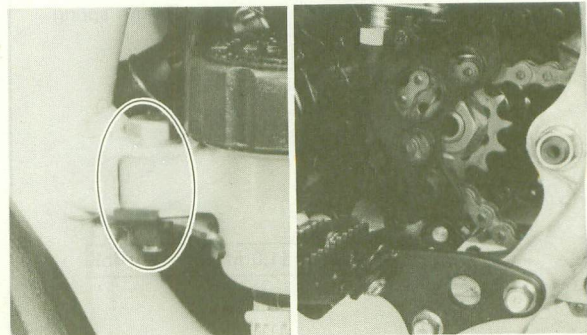

9. Remove the nut, lock washer, and drive sprocket.

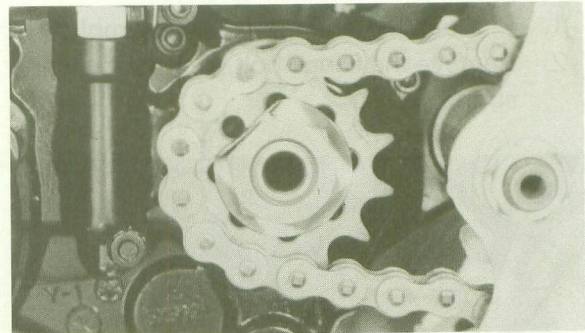

10. Remove the front and center lower mounting bolt. Remove pivot shaft.

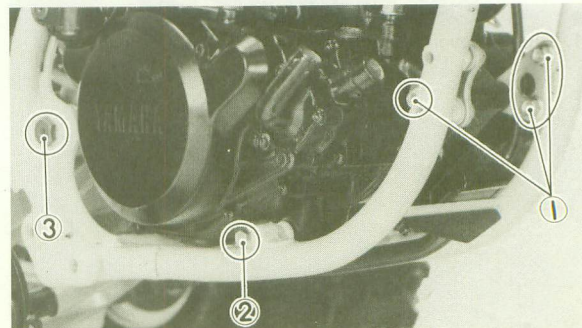

1. Front mounting bolt
2. Center lower mounting bolt
3. Pivot shaft

NOTE:

The engine and rear arm are installed using the same pivot shaft. Therefore take care so that the pivot shaft is pulled, not entirely out but further enough to set the engine free.

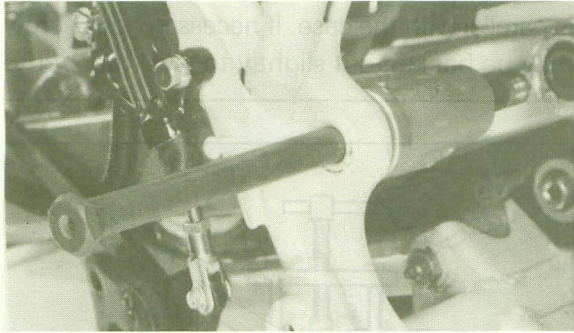

Bolt		Tightening torque
Front	Bracket to frame	30 Nm (3.0 m·kg, 22 ft·lb)
	Bracket to engine	30 Nm (3.0 m·kg, 22 ft·lb)
Center, Lower		30 Nm (3.0 m·kg, 22 ft·lb)

Upper	Bracket to frame	30 Nm (3.0 m·kg, 22 ft·lb)
	Bracket to engine	55 Nm (5.5 m·kg, 40 ft·lb)

Pivot shaft nut:
85 Nm (8.5 m·kg, 60 ft·lb)

When installing the pivot shaft, grease it.

2. Install drive sprocket.

Drive sprocket nut torque:
75 Nm (7.5 m·kg, 54 ft·lb)

ENGINE MOUNTING

Reverse the removal procedure while taking the following care:

1. Install engine mounting bolts and nuts with proper tightening torque.

CRANKCASE

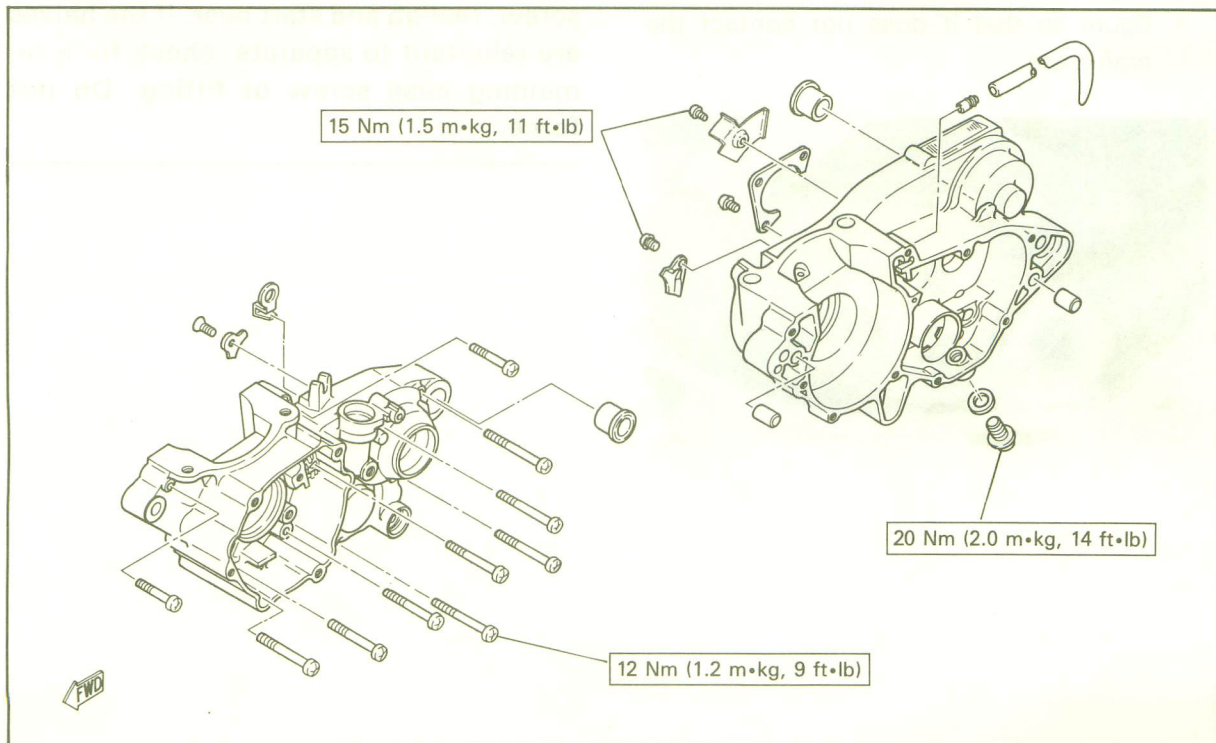

Crankcase Disassembly

1. Working in a crisscross pattern, loosen panhead screws 1/4 turn each. Remove them after all are loosened.

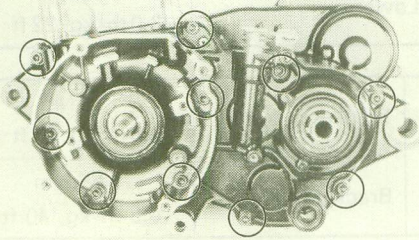

2. Remove the oil seal retainer.

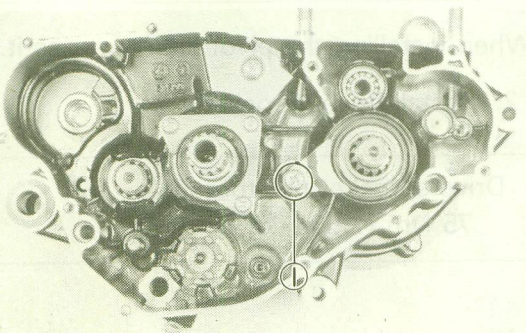

1. Retainer

3. Before separating the crankcase, turn the segment to the position shown in the figure so that it does not contact the crankcase.

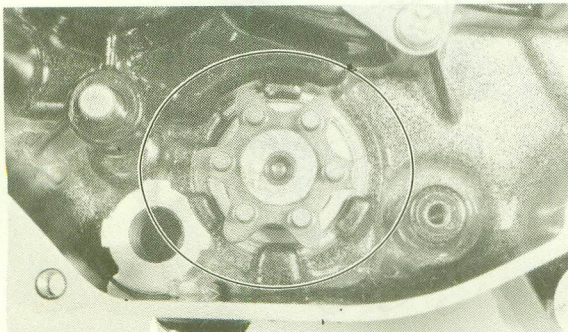

4. Install crankcase separating tool as shown.

NOTE:

Tighten the securing bolts on the crankcase separating tool, but make sure the tool body is parallel with the case. If necessary, one screw may be backed out slightly to level tool body.

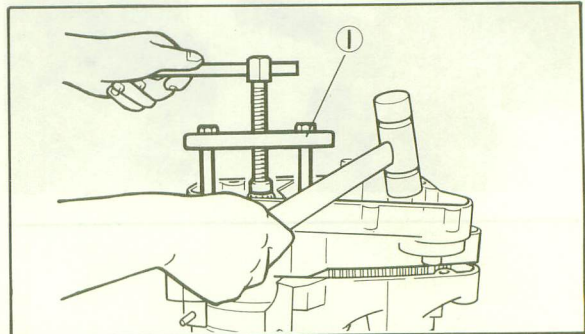

1. Crankcase separating tool

CAUTION:

Use a soft hammer to tap on the case half. Tap only on reinforced portions of case. Do not tap on gasket mating surface. Work slowly and carefully. Make sure the case halves separate evenly. If one end "hangs up," take pressure off the push screw, realign and start over. If the halves are reluctant to separate, check for a remaining case screw or fitting. Do not force.

TRANSMISSION AND SHIFTER

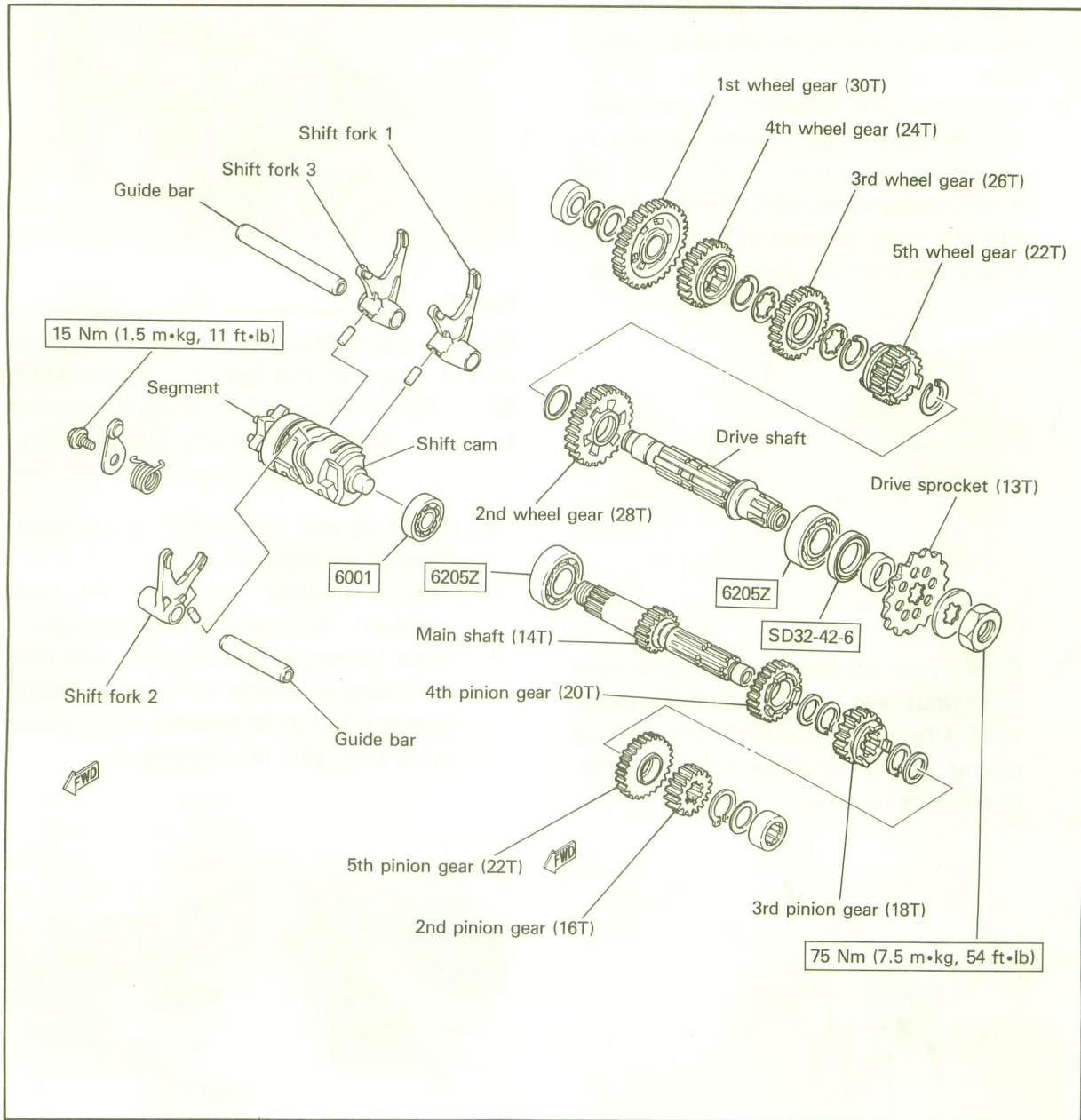

1. Tap lightly on the transmission drive shaft with a soft hammer to remove.

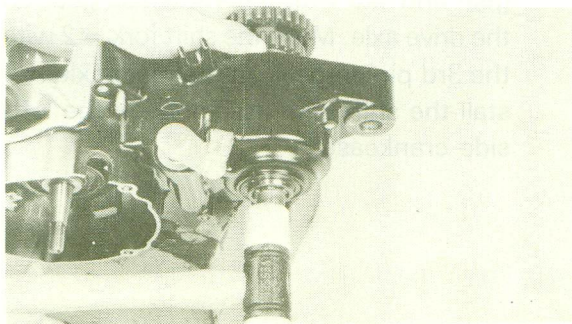

NOTE: _____
 Remove assembly carefully. Note the position of each part. Pay particular attention to the location and direction of shift forks.

Inspection

1. Inspect each shift fork for signs of galling on gear contact surfaces. Check for bending. Make sure each fork slides freely on its guide bar.

2. Check the shift cam grooves for signs of wear or damage. If any profile has excessive wear and/or any damage, replace cam.
3. Check the cam followers on each shift fork for wear. The follower should fit snugly into its seat in the shift fork, but should not be overly tight. Check the ends that ride in the grooves in the shift cam. *If they are worn or damaged, replace.*

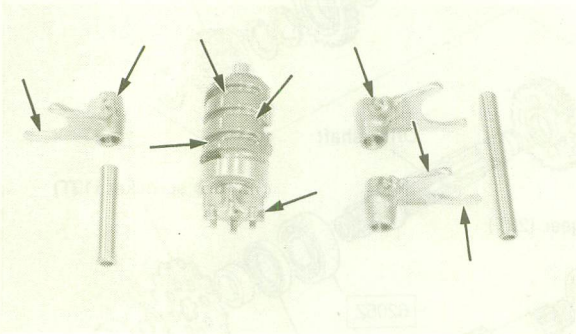

4. Carefully inspect each gear. Look for signs of obvious heat damage (blue discoloration). Check the gear teeth for signs of pitting, galling, or other extreme wear. Replace as required.

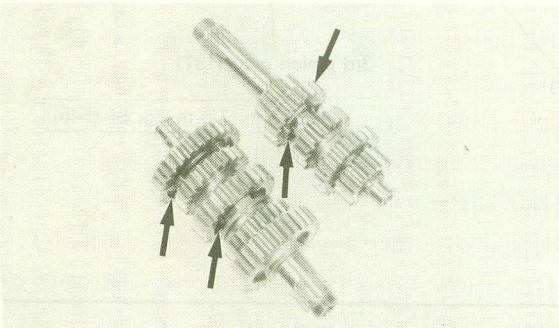

5. Check to see that each gear properly engages its counterpart on the shaft. Check the mating dogs for rounded edges, cracks, or missing portions. Replace as required.

Bearings and Oil Seals

1. After cleaning and lubricating the bearings, rotate inner race with a finger. If *rough spots* are noticed, replace the bearing.

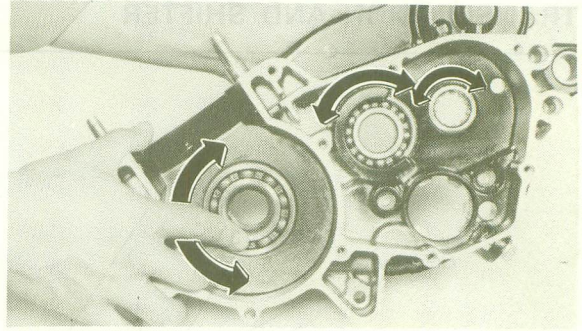

NOTE:

Bearing(s) are most easily removed or installed if the cases are first heated to approximately 90° ~ 120°C (194° ~ 248°F). Bring the case up to proper temperature slowly. Use an oven.

2. Check oil seal lips for damage or wear. Replace as required.
3. Always replace crankshaft oil seals whenever the crankshaft is removed.
4. Install bearing(s) and oil seal(s) with their manufacturer marks or numbers facing outward. Before installation, apply grease to oil seal lip(s) and bearing(s).

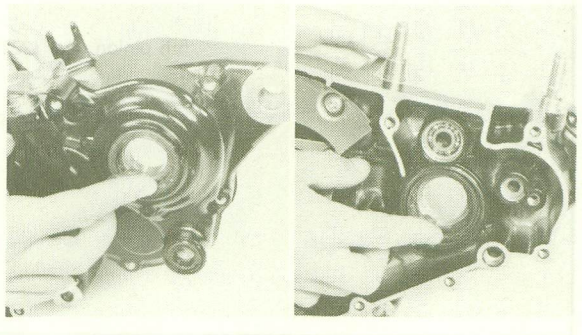

Transmission Installation

1. Mesh the shift fork # 1 with the 5th wheel gear and # 3 with the 4th wheel gear on the drive axle. Mesh the shift fork # 2 with the 3rd pinion gear on the main axle. Install the shift cam assembly on the left-side crankcase.

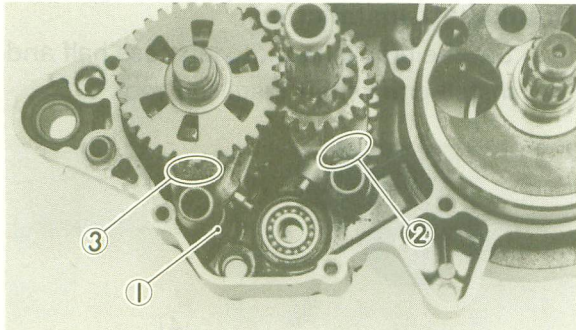

1. Shift fork #1 2. Shift fork #2 3. Shift fork #3

NOTE: _____

Install the each shift forks with the embossed model number should face upward.

2. Check to see that all parts move freely and that all loose shims are in place. Make sure all shafts are fully seated.

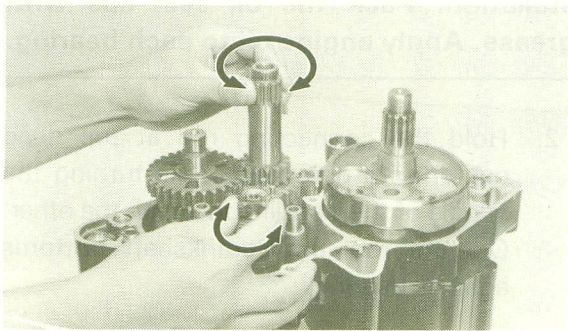

3. Thoroughly clean the case mating surfaces of oil or grease with lacquer thinner. Apply YAMAHA BOND #4 to the mating surfaces of both case halves.

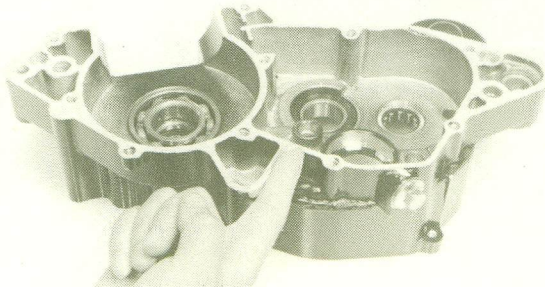

NOTE: _____

- a. Do not tap on machined surface or end of crankshaft.
- b. Before installing the crankshaft, check the crankshaft O-ring for damage.

4. After reassembly, apply a liberal coating of two-stroke oil to the crank pin and bearing and into each crankshaft bearing oil delivery hole.
5. Check crankshaft and transmission shafts for proper operation and freedom of movement.

CRANKSHAFT

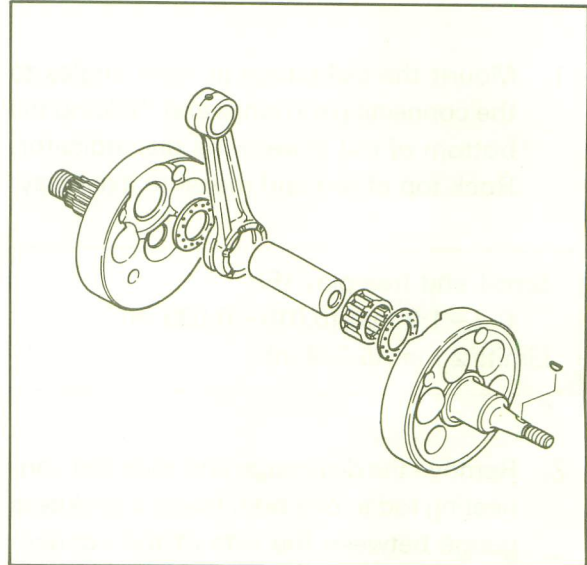

1. Remove crankshaft assembly with crankcase separating tool.

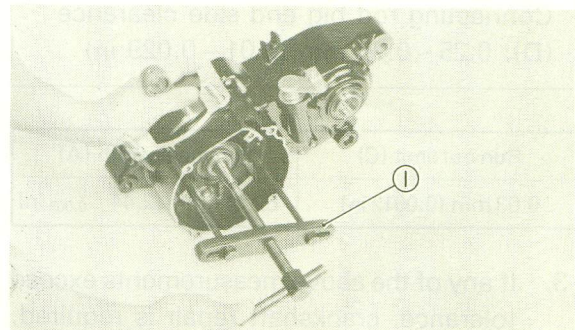

1. Crankcase separating tool

Inspection

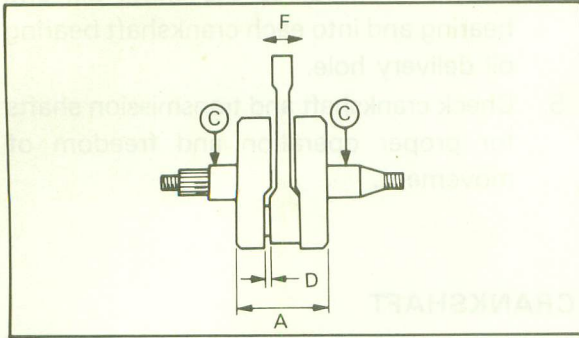

1. Mount the dial gauge at right angles to the connecting rod small end, holding the bottom of rod toward the dial indicator. Rock top of rod and measure axial play.

Small end free play (F):
 0.4~1.0 mm (0.016~0.039 in)
 Limit: 2 mm (0.079 in)

2. Remove the dial gauge and slide the connecting rod to one side. Insert a thickness gauge between the side of the connecting rod big end and the crank wheel. Measure clearance.

Connecting rod big end side clearance (D): 0.25~0.75 mm (0.01~0.029 in)

Run out limit (C)	Flywheel width (A)
0.03 mm (0.0012 in)	62 ⁺⁰ _{-0.05} mm (2.44 ⁺⁰ _{-0.002} in)

3. If any of the above measurements exceed tolerance, crankshaft repair is required. Take the machine to your authorized Yamaha dealer.

Crankshaft Installation

1. Set the crankshaft into left case half and install crankshaft installing tool.

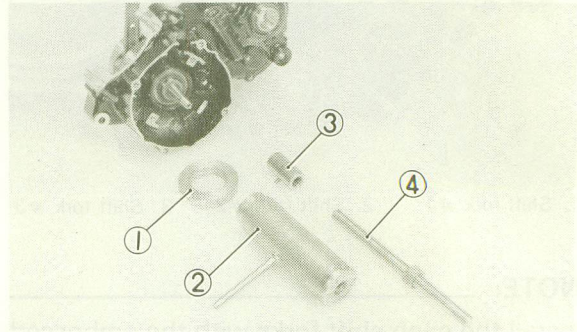

1. Spacer
2. Crankshaft installing pot
3. Adapter
4. Crankshaft installing bolt

CAUTION:

To protect the crankshaft against scratches or to facilitate the operation of installation: Pack the oil seal lips with grease. Apply engine oil to each bearing.

2. Hold the connecting rod at top dead center with one hand while turning the handle of the installing tool with the other. Operate tool until crankshaft bottoms against bearing.

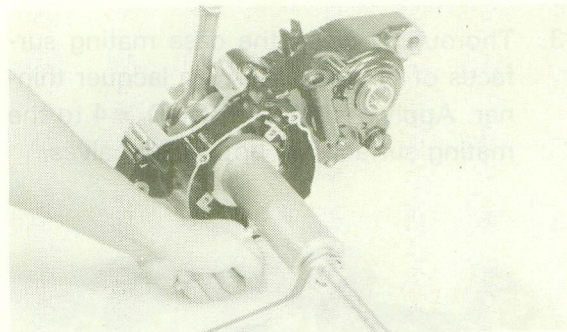

COOLING SYSTEM

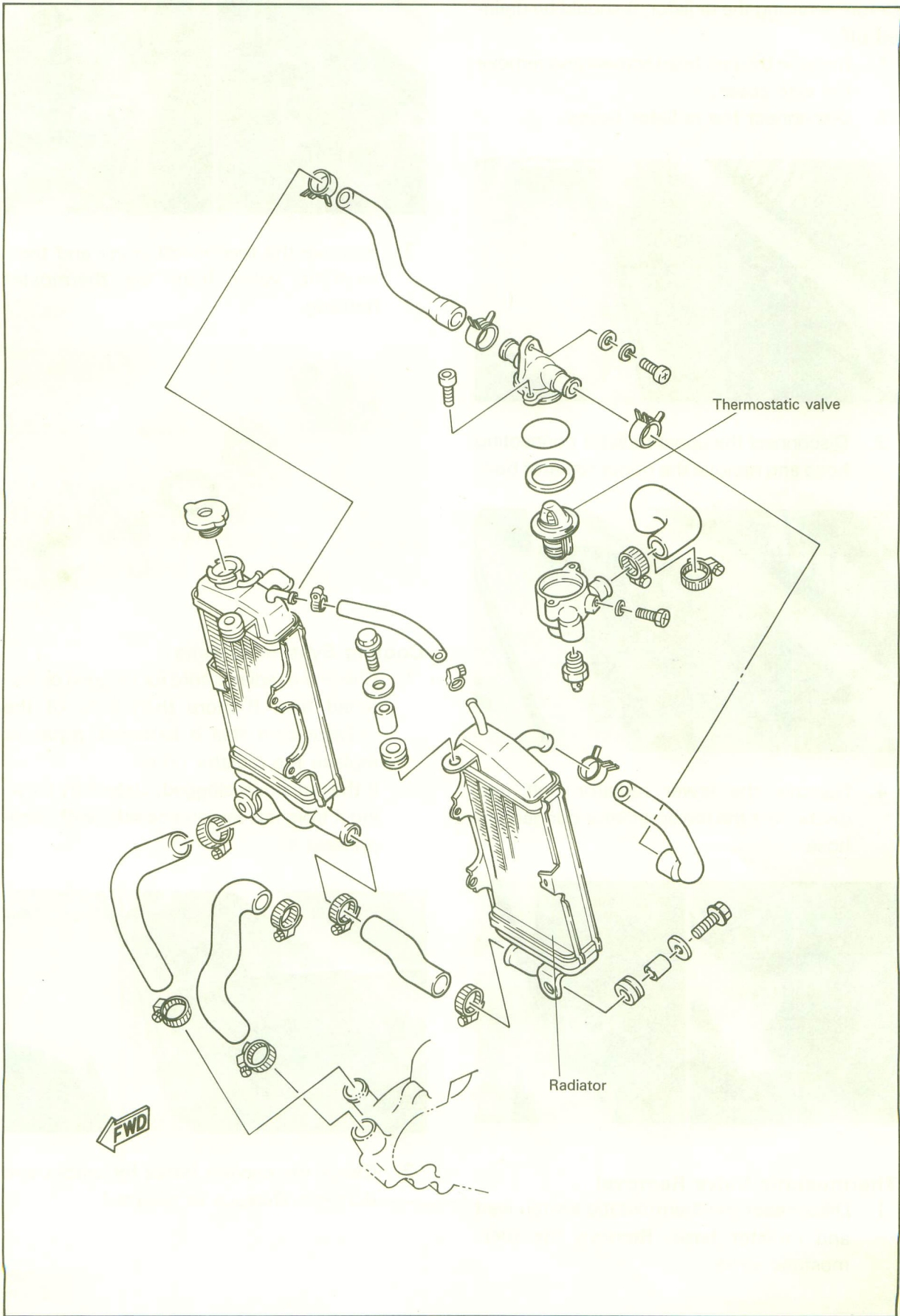

Radiator Removal

Before servicing the radiator, it should be drained off.

1. Remove the pan head screws and remove the side cover.
2. Disconnect the radiator hoses.

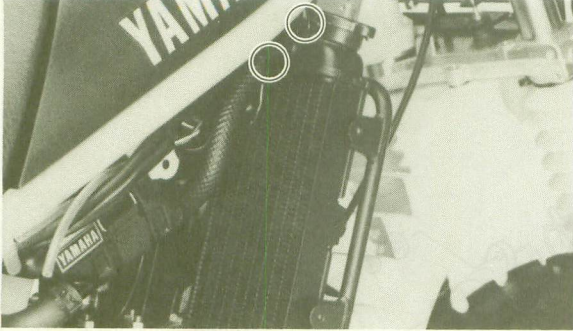

3. Disconnect the upper radiator connecting hose and remove the upper radiator bolt.

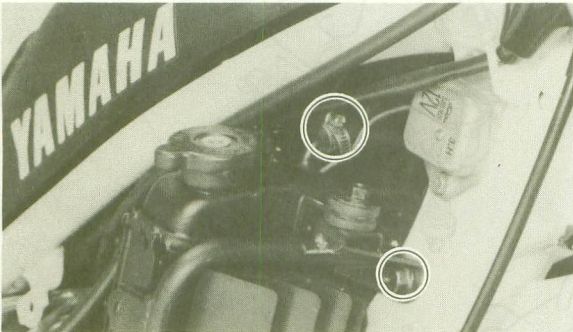

4. Remove the lower radiator bolt and disconnect the lower radiator connecting hose.

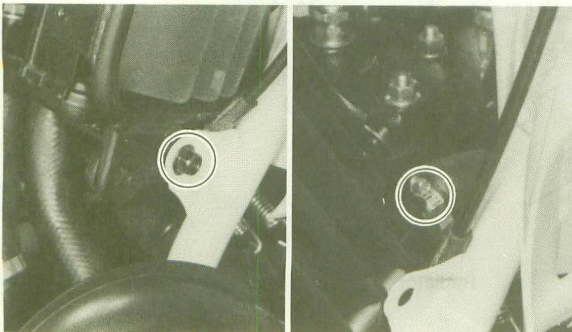

Thermostatic Valve Removal

1. Disconnect the thermostatic switch lead and radiator hose. Remove the thermostatic valve.

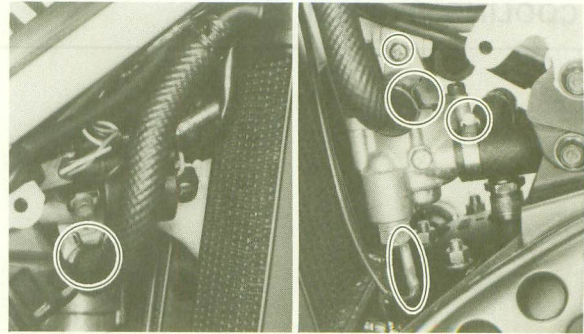

2. Remove the thermostat cover and thermostatic valve from the thermostat housing.

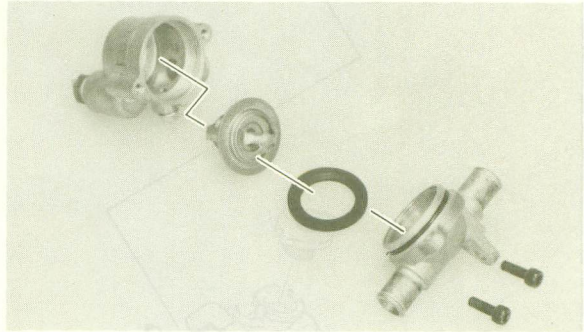

Cooling System Checks

1. Check the radiator core for clogged or flattened fins. If more than 20% of the radiator core area is flattened, repair or replace the radiator core. If the radiator is clogged, clean it by blowing it from its rear (engine side) with compressed air.

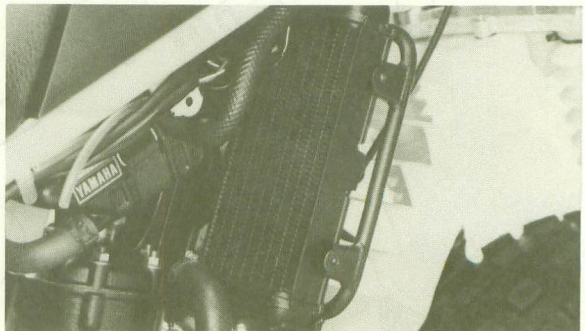

2. Check the coolant hoses for cracks and damage. Replace as required.

- Inspect the cooling system for leaks. Attach the cap tester to the radiator and pump it to the specified pressure. If the pressure gauge drops, inspect all hoses, fittings and radiator for an external leak. If leakage is found, repair or replace defective parts.

Pressure:

98.1 kPa (1.0 kg/cm², 14.2 psi)

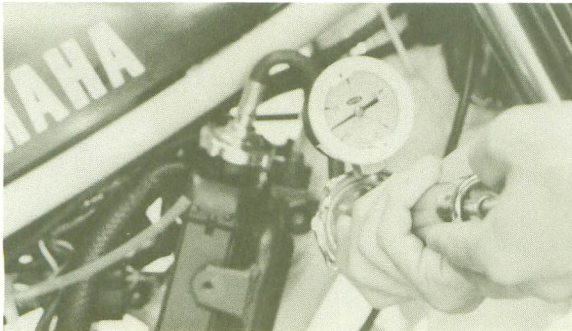

- Using the cap tester, check that the radiator cap vacuum valve and pressure valve operate correctly. Measuring with a tester, apply the specified pressure for 10 seconds, and make sure there is no pressure drop. If the air pressure shows a drop, replace the radiator filler cap.

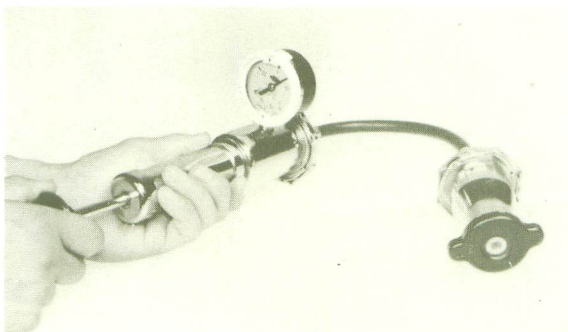

Valve opening pressure:

93.2 ~ 122.6 kPa (0.95 ~ 1.25 kg/cm², 13.5 ~ 17.8 psi)

- Suspend thermostatic valve in a vessel of water that contains a reliable thermometer.

Heat the water slowly. Then note the thermometer reading while stirring the water continually.

The thermostatic valve should begin to open at 63 ~ 67°C (145.4 ~ 152.6°F).

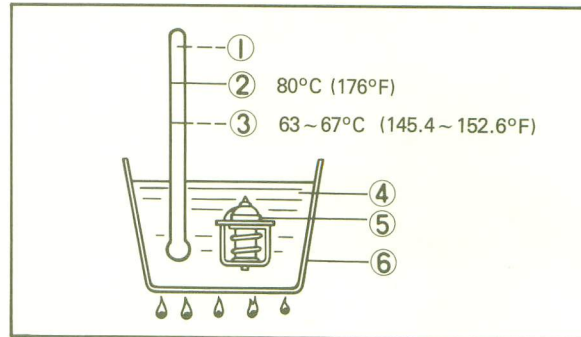

- | | |
|------------------|-----------------------|
| 1. Thermometer | 4. Water |
| 2. Full open | 5. Thermostatic valve |
| 3. Begin to open | 6. Vessel |

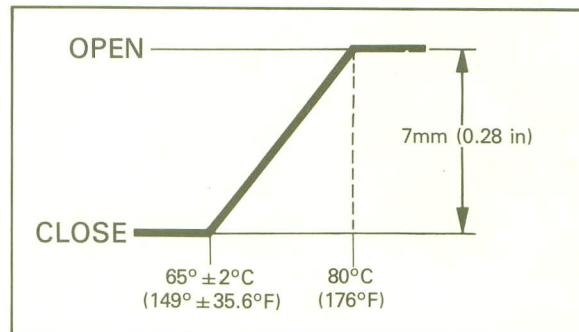

NOTE:

Thermostat is sealed and its setting is specialized work. Always replace if its accuracy is in doubt. A faulty unit could cause serious overheating or overcooling.

4 CHASSIS MAINTENANCE AND REPAIR

FRONT WHEEL	4-1
Removal	4-1
Front Axle Inspection	4-1
Front Wheel Inspection	4-1
Replacing the Wheel Bearings	4-1
Installing the Front Wheel	4-2
REAR WHEEL	4-2
Removal	4-2
Rear Wheel Inspection	4-2
Installing the Rear Wheel	4-2
FRONT BRAKE	4-3
Brake Pad Replacement	4-3
Caliper Disassembly	4-3
Master Cylinder Disassembly	4-4
Brake Inspection and Repair	4-4
Brake Assembly	4-5
REAR BRAKE	4-7
Brake Pad Replacement	4-7
Caliper Disassembly	4-7
Master Cylinder Disassembly	4-7
Brake Inspection and Repair	4-8
Brake Assembly	4-8
FRONT FORK	4-9
Fork Oil Replacement	4-12
Removal and Disassembly	4-13
Inspection	4-14
Assembly	4-14
STEERING HEAD	4-17
Adjustment	4-18
Removal	4-18
Inspection	4-19
Installation	4-19
REAR SHOCK (MONOCROSS SUSPENSION "DE CARBON" SYSTEM)	4-21
Rear Shock Setting	4-22
Handling Notes	4-23
Notes on Disposal (Yamaha dealers only)	4-23
Removal	4-23
Installation	4-24

SWINGARM	4-25
Swingarm Free Play Inspection	4-26
Removal	4-26
Inspection	4-27
Assembly	4-28

DRIVE CHAIN	4-29
--------------------------	-------------

4 CHASSIS MAINTENANCE AND REPAIR

Whenever performing chassis work, always take extra care and double-check each step of each procedure. The wheels, brakes, suspension, steering, and frame must all be in top condition to provide optimum performance, reliability, and safety.

FRONT WHEEL

Removal

1. Elevate the front wheel by placing a suitable stand under the frame.

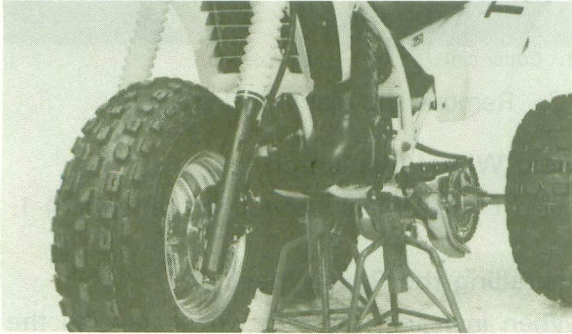

2. Loosen the front axle pinch bolt.

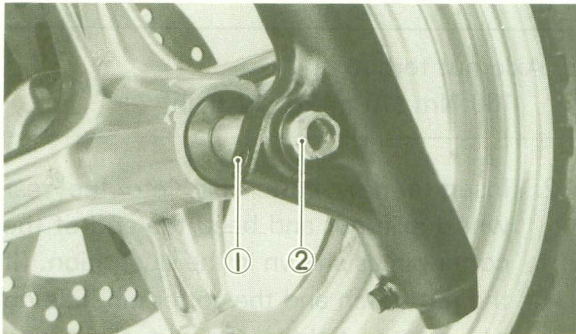

1. Pinch bolt 2. Front axle

3. Remove the front wheel axle, collars, and front wheel assembly from the front fork.

Front Axle Inspection

Remove any corrosion from the axle with emery cloth. Place the axle on a surface plate and check for bend. If bent, replace the axle. Do not attempt to straighten a bend.

Front Wheel Inspection

1. Check for cracks, bends or warpage of the wheels. If a wheel is deformed or cracked, it must be replaced.

2. Check wheel runout.

If deflection exceeds tolerance below, check the wheel bearing or replace wheel as required.

Rim runout limits:

Vertical - 2.0 mm (0.08 in)

Lateral - 2.0 mm (0.08 in)

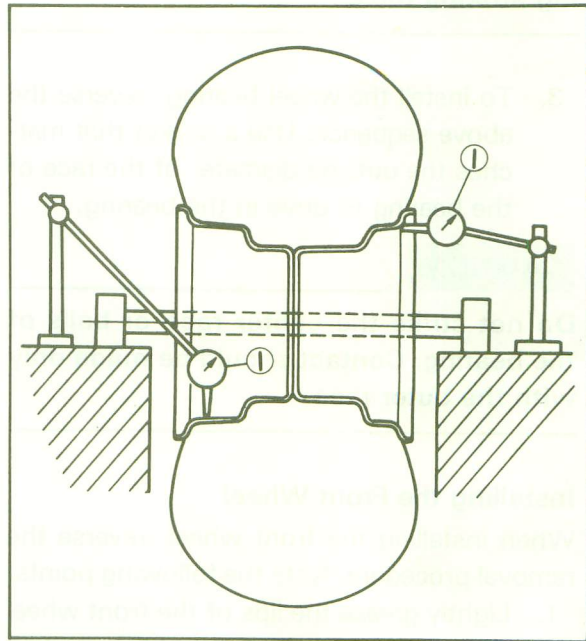

1. Dial gauge

Replacing the Wheel Bearings

If the bearings allow play in the wheel hub or if the wheel does not turn smoothly, replace the bearings as follows:

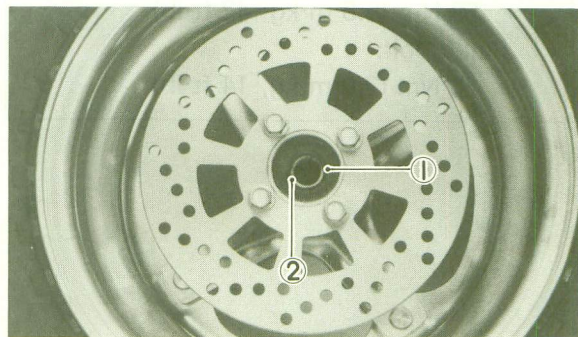

1. Oil seal 2. Bearing

1. Clean the outside of the wheel hub.
2. Drive the bearing out by pushing the spacer aside and tapping around the perimeter of the bearing inner race with a soft metal drift punch and hammer. The spacer "floats" between the bearings. Both bearings can be removed in this manner.

WARNING:

Eye protection is recommended when using striking tools.

3. To install the wheel bearing, reverse the above sequence. Use a socket that matches the outside diameter of the race of the bearing to drive in the bearing.

CAUTION:

Do not strike the center race or balls of the bearing. Contact should be made only with the outer race.

Installing the Front Wheel

When installing the front wheel, reverse the removal procedure. Note the following points.

1. Lightly grease the lips of the front wheel oil seals. Use lightweight lithium soap base grease.
2. Tighten the front axle and pinch bolt.

TIGHTENING TORQUE:

Front axle:
58 Nm (5.8 m·kg, 42 ft·lb)
Pinch bolt:
20 Nm (2.0 m·kg, 14 ft·lb)

REAR WHEEL

Removal

1. Block the front tire and jack up the rear of the vehicle. Apply the rear brake.
2. Remove the cotter pin and axle nut.

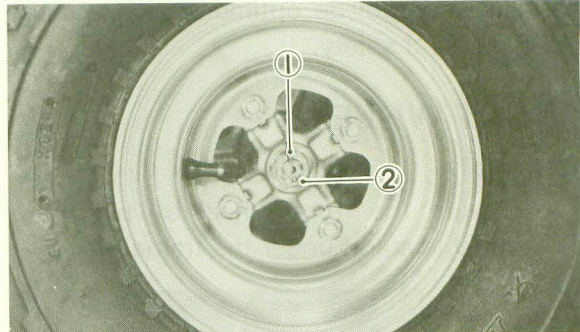

1. Cotter pin 2. Axle nut

3. Remove the rear wheel assembly.

Rear Wheel Inspection

See "Front Wheel Inspection" on page 4-1.

Installing the Rear Wheel

When installing the rear wheel, reverse the removal procedure. Note the following points.

1. Tighten axle nut.

Axle nut torque:
100 Nm (10 m·kg, 72 ft·lb)

2. Insert a new cotter pin into the rear wheel axle nut and bend the end of the cotter pin as shown in the illustration. (If the nut notch and the cotter pin hole do not match, tighten the nut slightly to align them.)

WARNING:

Always use a new cotter pin on the axle nut.

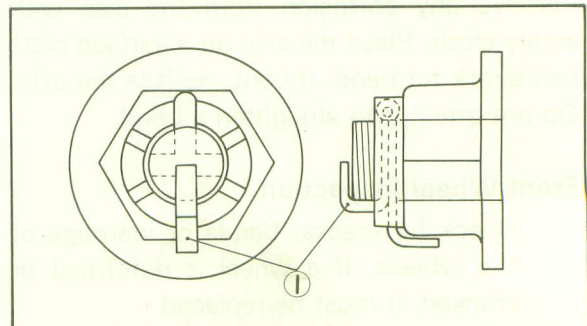

1. Cotter pin

FRONT BRAKE

CAUTION:

Disc brake components rarely require disassembly. Do not disassemble components unless absolutely necessary. If any hydraulic connection in the system is opened, the entire system should be disassembled, drained, cleaned, and then properly filled and bled upon reassembly. Do not use solvents on brake internal components. Solvents will cause seals to swell and distort. Use only clean brake fluid for cleaning. Use care with brake fluid. Brake fluid can injure your eyes, and it will damage painted surfaces and plastic parts.

Brake Pad Replacement

1. Remove the caliper bolts and caliper from the front fork. Remove the pad retaining bolt.

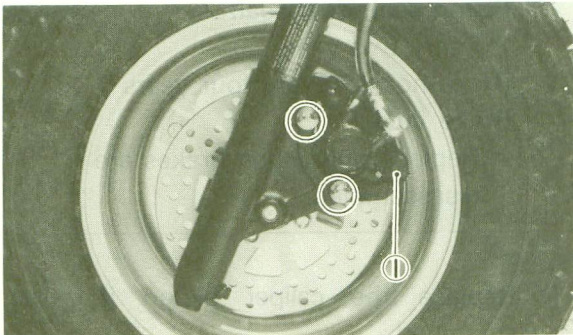

1. Pad retaining bolt

2. Remove the pads.

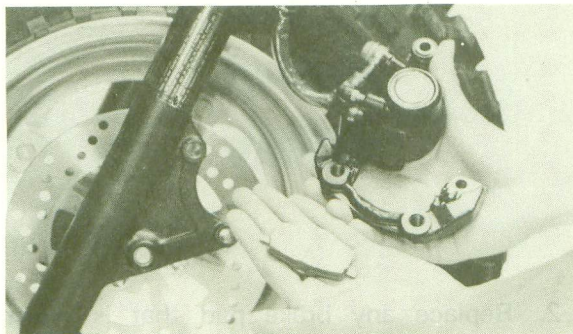

3. Install the new brake pads. Replace the following parts if pad replacement is required.

- Pads
- Pad spring

NOTE:

Replace the pads as a set if either is found to be worn to the wear limit.

Pad wear limit:
0.8 mm (0.032 in)

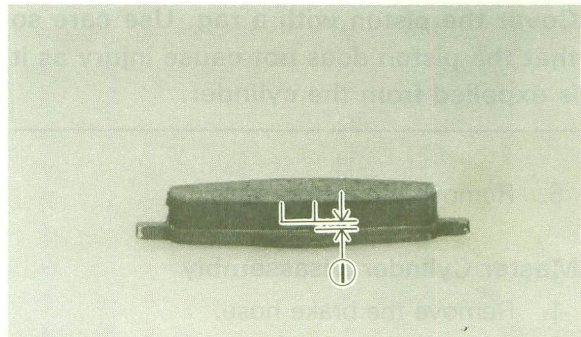

1. Wear limit

4. Tighten the pad retaining bolt and caliper bolts to specification.

Pad retaining bolt:
23 Nm (2.3 m·kg, 17 ft·lb)
Caliper bolt:
35 Nm (3.5 m·kg, 25 ft·lb)

Caliper Disassembly

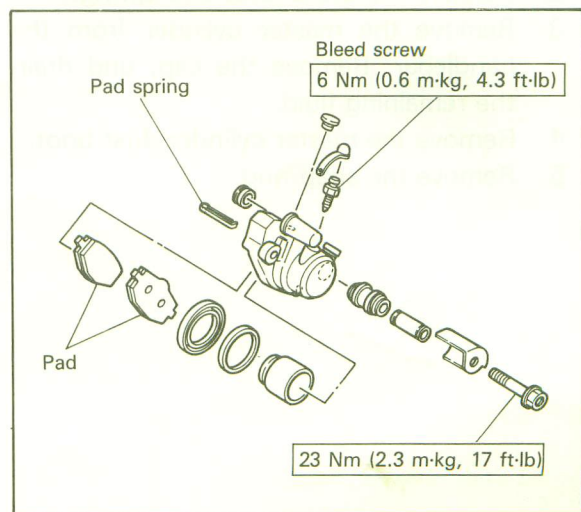

1. Remove the brake hose from the caliper. Allow the caliper assembly to drain into a container.
2. Place the open hose end into the container and pump the old fluid out of the master cylinder.
3. Remove the caliper cylinder securing bolts from the front fork.
4. Remove the retaining bolt, pads, and pad spring.
5. Carefully force the piston out of the caliper cylinder with compressed air. Never try to pry out the piston.

WARNING:

Cover the piston with a rag. Use care so that the piston does not cause injury as it is expelled from the cylinder.

6. Remove the piston seals.

Master Cylinder Disassembly

1. Remove the brake hose.

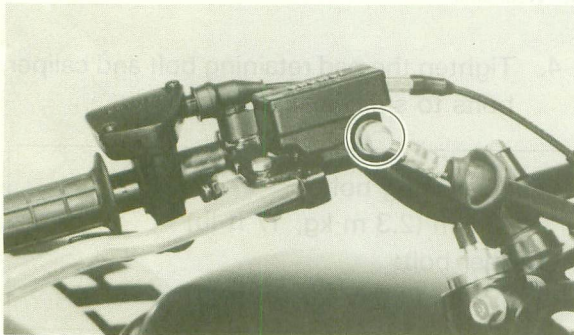

2. Remove the brake lever and spring.
3. Remove the master cylinder from the handlebar. Remove the cap, and drain the remaining fluid.
4. Remove the master cylinder dust boot.
5. Remove the snap ring.

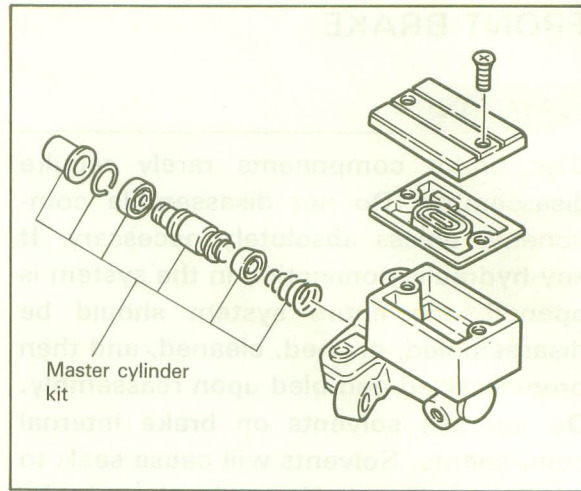

6. Remove the master cylinder cup assembly. Note that the cylinder cups are installed with the larger diameter (lips) inserted first.

Brake Inspection and Repair

Recommended brake component

Replacement schedule:

Brake pads: As required

Piston seal, dust seal:

Every two years

Brake hoses: Every four years

Brake fluid:

Replace only when brakes are disassembled.

1. Replace the caliper piston if it is scratched.

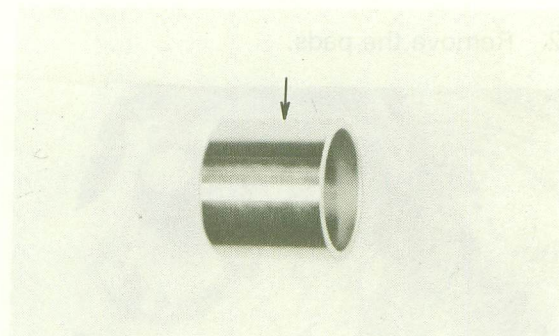

2. Replace any brake pad that is worn beyond limits. Always replace the brake pads as a set. See "Brake Pad Replacement" for a listing of the parts to be replaced when pads are replaced.

Wear limit: 0.8 mm (0.032 in)

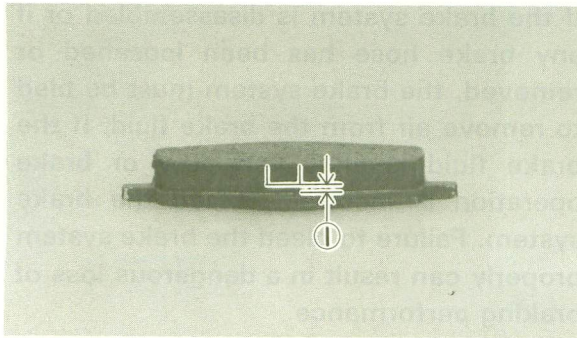

1. Wear limit

3. Replace the piston seals if damaged. Replace the seals every two years.
4. Inspect the master cylinder body; replace if scratched. Clean all the passages with new brake fluid.
5. Inspect the brake hoses. Replace the hoses every four years or immediately if cracked, frayed, or damaged.
6. Check for wear and deflection of the disc. If the disc is worn beyond minimum thickness or if deflection exceeds the specified amount, replace the disc.

Maximum deflection:

0.15 mm (0.006 in)

Minimum disc thickness:

3.5 mm (0.14 in)

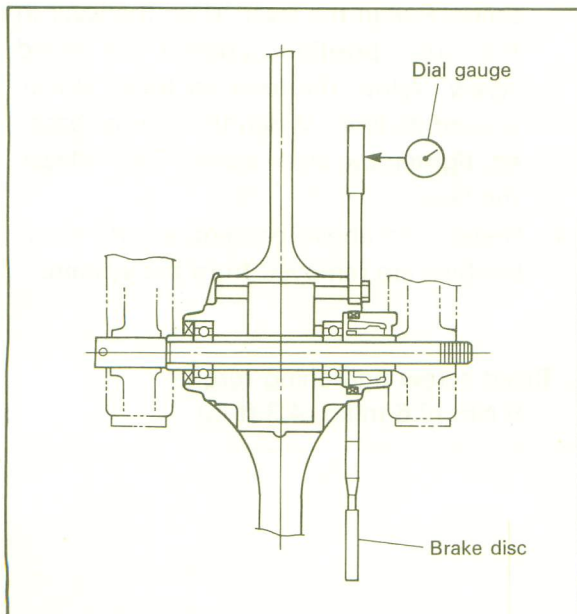

Brake Assembly

Caliper

All internal parts should be cleaned in *new* brake fluid only. Internal parts should be lubricated with brake fluid when installed. Replace the following parts whenever a caliper is disassembled:

- Piston seals
- Retaining ring
- Rubber boot
- Bleed screw and rubber cap

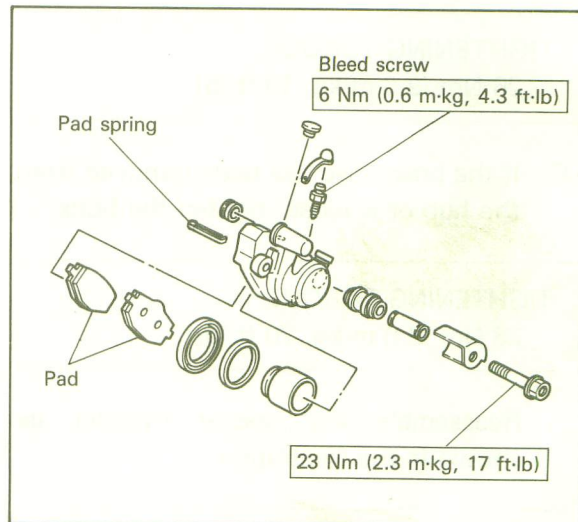

1. Install the piston seals and the piston.
2. Install the pad springs, pads, and retaining bolt into the caliper cylinder. Torque the retaining bolt to specification.

TIGHTENING TORQUE:

23 Nm (2.3 m·kg, 17 ft·lb)

3. Apply rubber grease to the piston seals, caliper cylinder, and piston.
4. Install the caliper assembly on the front fork. Torque the bolts to specification.

TIGHTENING TORQUE:

35 Nm (3.5 m·kg, 25 ft·lb)

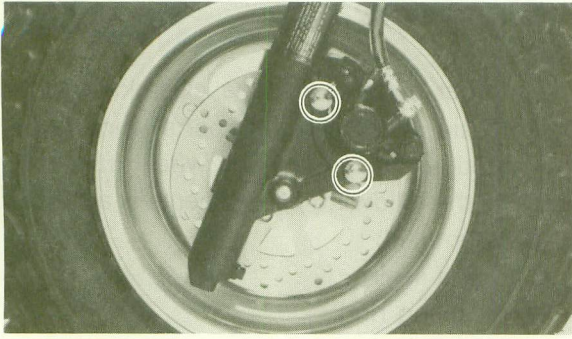

5. Attach the brake hoses.

TIGHTENING TORQUE:
26 Nm (2.6 m·kg, 19 ft·lb)

6. If the brake disc has been removed from the hub or is loose, tighten the bolts.

TIGHTENING TORQUE:
28 Nm (2.8 m·kg, 20 ft·lb)

7. Reassemble the master cylinder as shown in the illustration.

TIGHTENING TORQUE:
(all brake union bolts)
26 Nm (2.6 m·kg, 19 ft·lb)

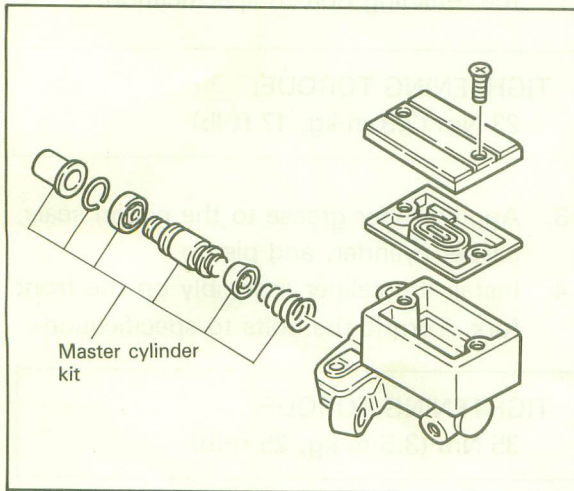

Bleeding the brakes

WARNING:

If the brake system is disassembled or if any brake hose has been loosened or removed, the brake system must be bled to remove air from the brake fluid. If the brake fluid level is very low or brake operation is incorrect, bleed the brake system. Failure to bleed the brake system properly can result in a dangerous loss of braking performance.

1. Add proper brake fluid to the reservoir. Install the diaphragm, being careful not to spill or overflow the reservoir.
2. Connect a clear plastic tube, 4.5 mm (3.16 in) inside diameter, tightly to the caliper bleed screw. Put the other end of the tube into a container.

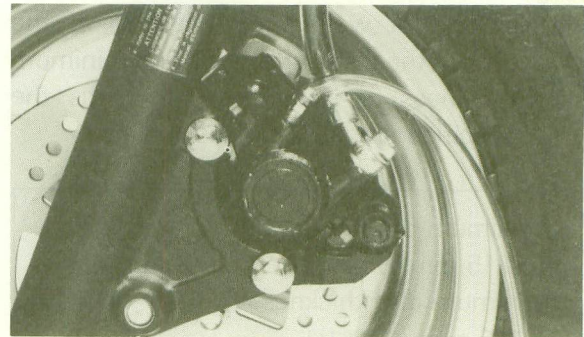

3. Slowly apply the brake lever several times. Pull in the lever. Hold the lever in this "on" position. Loosen the bleed screw. Allow the lever to travel slowly toward its limit. When the limit is reached, tighten the bleed screw. Then release the lever.
4. Repeat the above procedure until all air bubbles are removed from the system.

Bleed screw tightening torque:
6 Nm (0.6 m·kg, 4.3 ft·lb)

NOTE: _____

If bleeding is difficult, it may be necessary to let the brake fluid system stabilize for a few hours. Repeat the bleeding procedure when the tiny bubbles in the system have settled out.

REAR BRAKE

CAUTION: _____

Disc brake components rarely require disassembly. Do not disassemble components unless absolutely necessary. If any hydraulic connection in the system is opened, the entire system should be disassembled, drained, cleaned, and then properly filled and bled upon reassembly. Do not use solvents on brake internal components. Solvents will cause seals to swell and distort. Use only clean brake fluid for cleaning. Use care with brake fluid. Brake fluid can injure your eyes, and it will damage painted surfaces and plastic parts.

Brake Pad Replacement

It is not necessary to disassemble the brake caliper and brake hose to replace the brake pads.

1. Remove the retaining bolt from the caliper cylinder. Then remove the pads and pad spring.

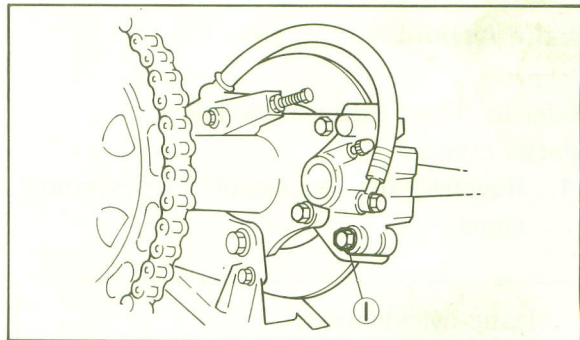

1. Retaining bolt

2. Follow the "Front Brake Pad Replacement 3 and 4".

Caliper Disassembly

Refer to "FRONT BRAKE".

Master Cylinder Disassembly

1. Loosen the locknut and remove the master cylinder securing bolts. Disconnect the brake hoses.

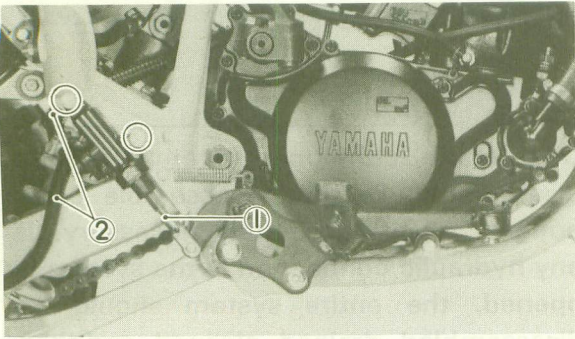

1. Locknut 2. Brake hose

2. Remove the master cylinder from brake pedal by turning master cylinder rod.
3. Remove the master cylinder kit parts.

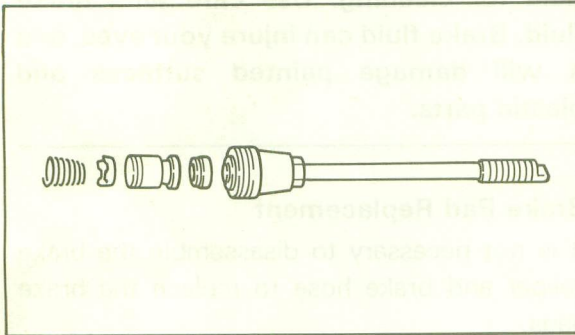

Brake Inspection and Repair

Refer to "Front Brake Inspection and Repair".

Brake Assembly

Caliper

Refer to "Front Brake Assembly".

Master cylinder

1. Reverse the applicable disassembly steps.

Master cylinder bolt:

20 Nm (2.0 m·kg, 14 ft·lb)

Brake hose union bolt:

26 Nm (2.6 m·kg, 19 ft·lb)

Bleeding the brakes

Refer to "Front Brake Bleeding the Brakes".

FRONT FORK

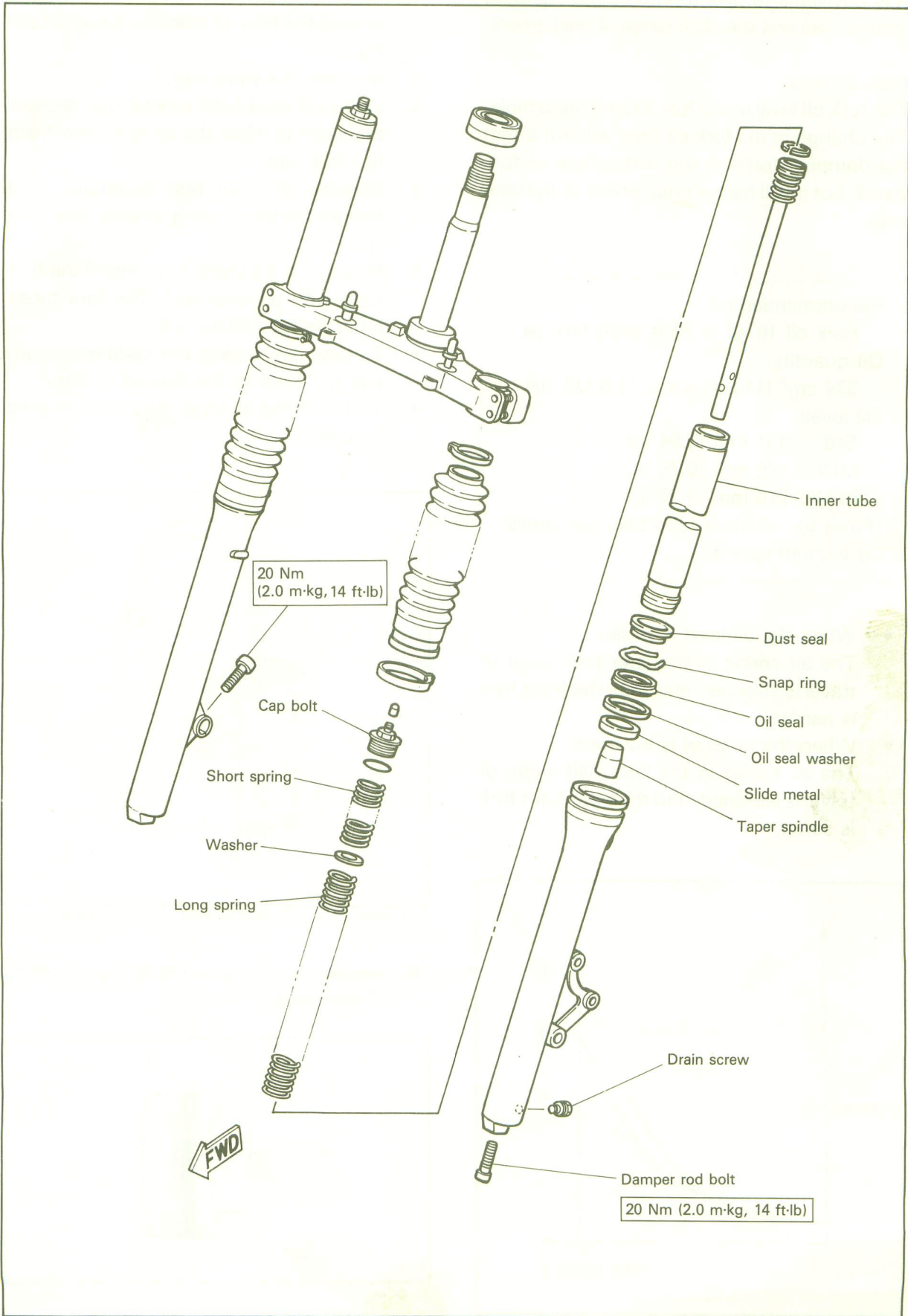

Front fork setting

It is advisable to take a note of the standard setting data and specified range of adjustment.

Fork oil level

The fork oil level in the fork tube is adjustable. The change in the fork oil level will not affect the damping force at the early stage of fork travel, but it will have a great effect at the later stage.

Recommended oil:

Fork oil 10 wt or SEA #10 fork oil

Oil quantity:

334 cm³ (11.8 Imp oz, 11.3 US oz)

Oil level:

Std 151 mm (5.94 in)

MIN. 146 mm (5.75 in)

MAX. 210 mm (8.27 in)

(From top of inner tube fully compressed without spring.)

- When the oil level is raised:
The air spring in the later half stage of travel is stronger, and thus the front fork is harder.
- When the oil level is lowered:
The air spring in the later half stage of travel is lessened, and thus the front fork is softer.

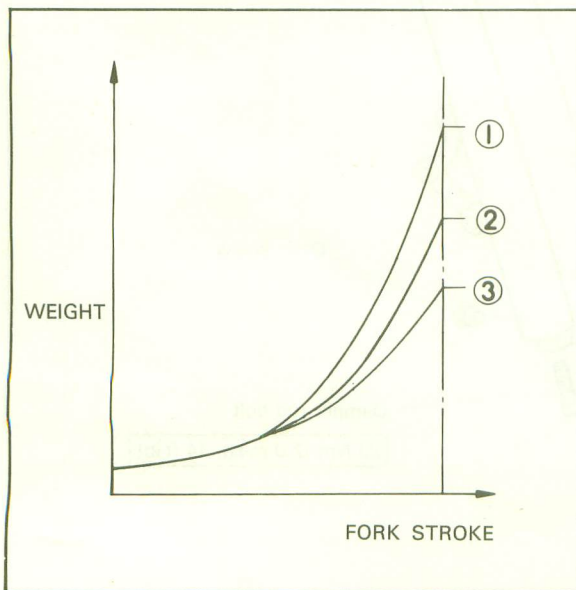

Oil level adjustment

1. Place a suitable stand under the engine to keep the front of machine raised off the floor.
2. Remove the valve cap.
3. Using a slotted-head screwdriver, depress the valve to allow the air to escape from the fork legs.
4. Remove the cap bolt assembly. And remove the short spring, washer, and long spring.
5. Measure the oil level from top of the fork tube with oil level tool. The fork tubes must be fully bottomed.
 - To raise the oil level, once add oil and adjust the level to the desired position.
 - To lower the oil level, it can be lowered straight.

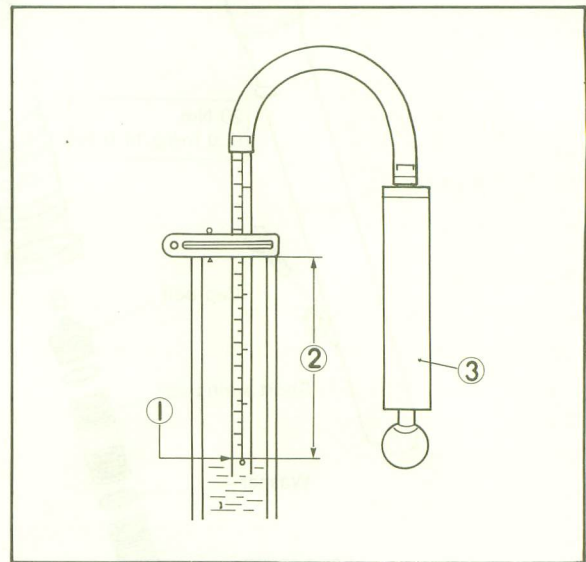

1. 0 point 2. Fork oil level 3. Oil level tool

6. Inspect the O-ring on cap bolt and replace if damaged.

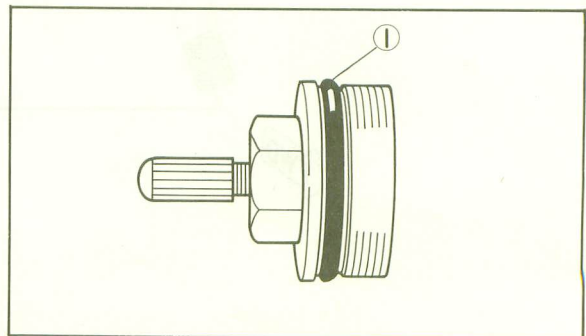



1. O-ring

Fork spring

In addition to the standard type, two different type fork springs are sold. A proper spring should be selected according to the conditions of a racing course or the weight of the rider.

NOTE:

Always check the oil levels before changing or re-installing springs.

Type	Spring	Spring rate (kg/mm)	Part number	Mark
Std.	Long	0.445	38W-23141-00	
	Short	1.880	38W-23351-00	
SOFT	Long	0.425	38W-23141-10	
	Short	1.700	38W-23351-10	
HARD	Long	0.495	38W-23141-20	
	Short	2.080	38W-23351-20	

Air pressure

Although it is possible to change the air pressure in the forks, it is better to change the oil level first to gain the desired air-spring effect. The change in the air pressure affects the air-spring effect throughout the entire range of fork travel.

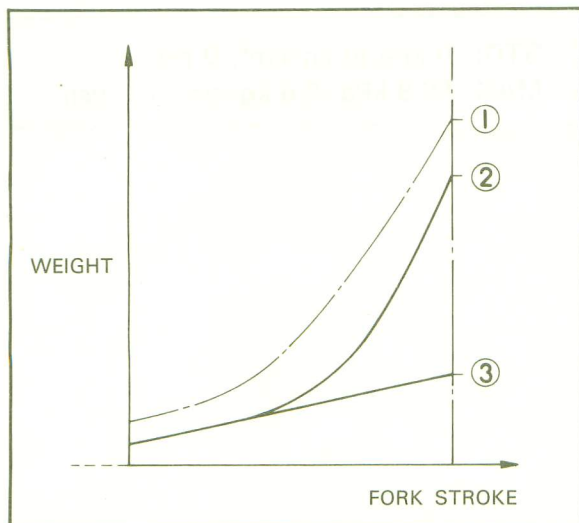

1. 0.2 kg/cm²
2. 0 kg/cm² (Air/coil spring)
3. Coil spring

- Increase air pressure → causes initial load to increase, and the fork becomes hard.
- Decrease air pressure → causes initial load to decrease, and the fork becomes soft.

Remember, 0 psi air pressure in forks and release any pressure build-up after each moto.

1. Place a suitable stand under the engine to keep the front of machine raised off the floor. No weight on front wheel.
2. Using a manual air pump, fill with air.
3. Using the air check gauge, adjust the air pressure to specification.

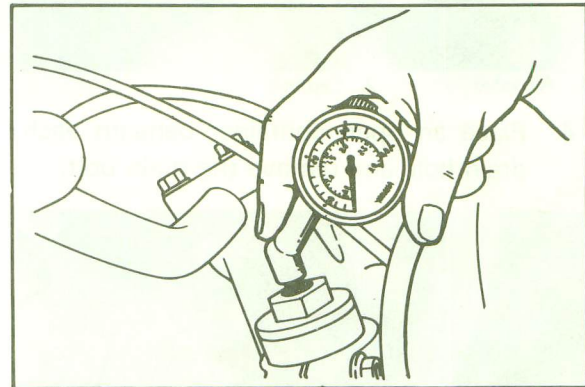

4. The difference between both right and left tubes should be 9.8 kPa (0.1 kg/cm², 1.4 psi) or less.

CAUTION:

Use only air or nitrogen for filling. Never use any other gas. An explosion may result.

STD: 0 kPa (0 kg/cm², 0 psi)
MAX: 5.88 kPa (0.6 kg/cm², 8.53 psi)

CAUTION:

The air pressure should not exceed 5.88 kPa (0.6 kg/cm², 8.53 psi). Excess air pressure will cause damage to the forks. Use only air for filling.

Fork Oil Replacement

1. Place a suitable stand under the engine to keep the front of machine raised off the floor.
2. Remove the valve cap and depress the air valve to allow the air to escape from the fork legs.
3. Remove the cap bolt assembly.

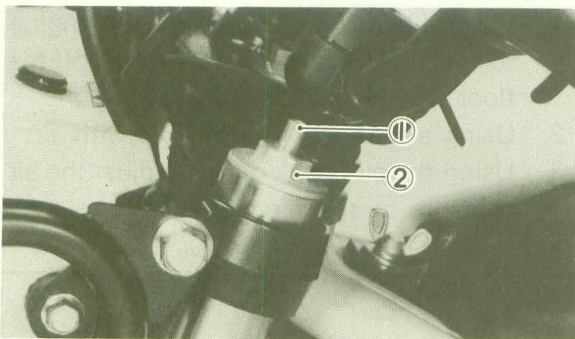

1. Air valve 2. Cap bolt

4. Place an open container beneath each drain hole and remove the drain bolt.

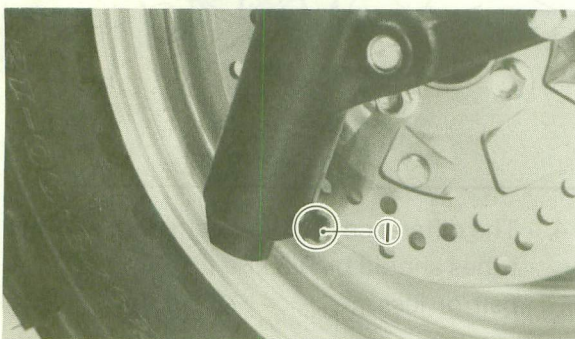

1. Drain bolt

5. After most of oil has drained, slowly raise and lower outer tubes to pump out remaining oil.
6. Install drain bolts.

NOTE: _____

Check gasket, replace if damaged.

7. Measure the correct amount of oil and pour it into each leg. After filling, allow it a few minutes and slowly pump the inner tube up and down 2 or 3 times so that air can be extracted from the oil.

Recommended oil:

Fork oil 10 wt or
SAE 10W motor oil

Oil quantity:

334 cm³ (11.8 Imp oz, 11.3 US oz)

8. Inspect the O-ring on the cap bolt; if it is cut or otherwise damaged, replace the O-ring.

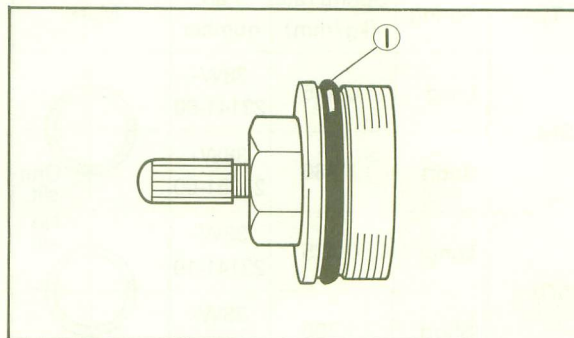

1. O-ring

9. Install the cap bolt, and torque to specification.

TIGHTENING TORQUE:

23 Nm (2.3 m·kg, 17 ft·lb)

- 10 Check the air pressure, and set it to specification.

Air pressure

STD: 0 kPa (0 kg/cm², 0 psi)

MAX: 58.8 kPa (0.6 kg/cm², 8.5 psi)

Removal and Disassembly

CAUTION:

To prevent an accidental explosion of air, the following instructions should be observed:

1. Use only air or nitrogen for filling. Never use any other gas. An explosion may result.
2. Never throw the front fork into fire.
3. Before removing the cap bolts or front forks, be sure to extract the air from the air chamber completely.

1. Place the machine on a suitable stand to keep it stable while the front wheel and forks are removed.
2. Let the air out of the forks, and remove the cap bolts.
3. Remove the front wheel and front brake caliper. Loosen the fork tube pinch bolts, and remove the forks.

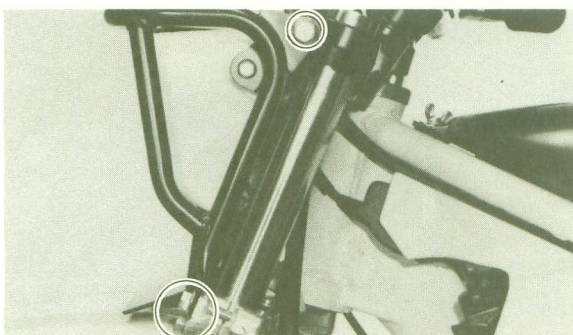
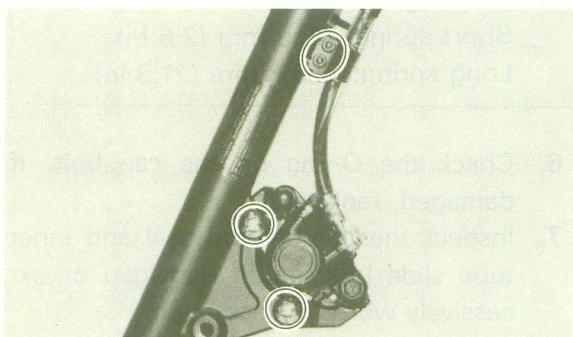

4. Remove the rubber boot, short spring, washer, and long spring.
5. Remove the dust seal and snap ring from the top of the outer tube.

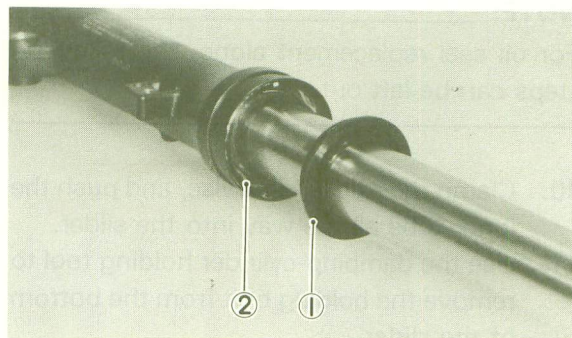

1. Dust seal 2. Snap ring

6. Fill the fork completely with fork oil and reinstall the cap bolt. Depress the air valve until oil flows out.
7. Place a spacer on top of the cap bolt, and place the fork leg in a hand press as illustrated. The spacer will keep the press from contacting the air valve.

CAUTION:

If the inner tube is abruptly contracted or air enters the inner tube, the oil may spurt out or the oil seal may spring out. Never touch the inner tube during disassembling operation. Also wrap the oil seal with a rag for safety.

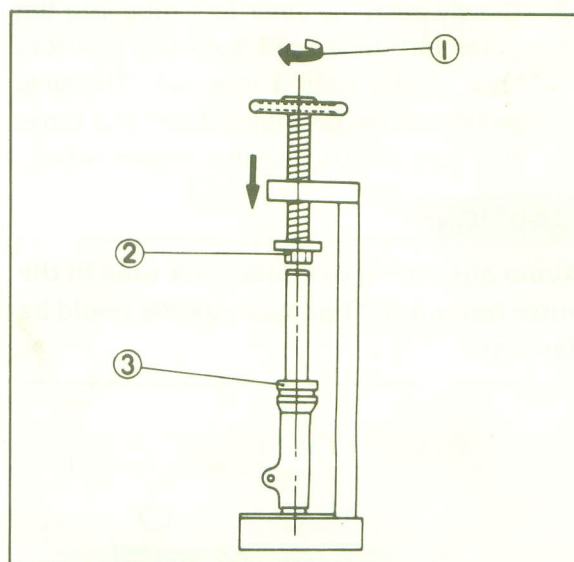

1. Turn slowly 2. Spacer 3. Wrap with rag

8. Wrap a rag around the top of the slider, and slowly turn the handle of the press until the oil seal is pushed out of the slider.
9. Remove the oil seal. *Discard the oil seal*, as the seal must always be replaced whenever the fork is disassembled.

NOTE: _____

For oil seal replacement alone, the following steps can be left out.

10. Clamp the axle lug in a vise, and push the inner tube all the way into the slider.
11. Use the damping-cylinder holding tool to remove the holding bolt from the bottom of the slider.

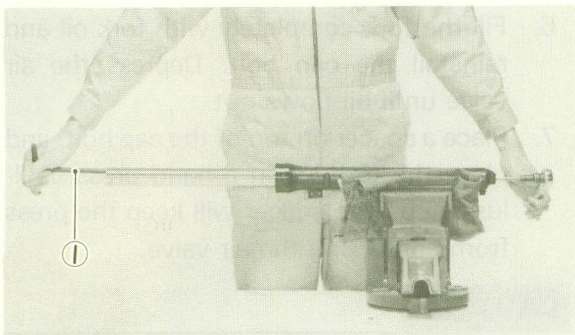

1. Cylinder holding tool

NOTE: _____

The holding bolt is locked with LOCTITE®. To remove it, tap it with a hammer several times so that it can be loosened.

12. Slowly push the inner fork tube into the outer fork tube, and then pull the fork back quickly until it tops out. The slide metal will be dislodged from the outer fork tube after doing this several times.

CAUTION: _____

Avoid bottoming the inner fork tube in the outer fork tube. The taper spindle could be damaged.

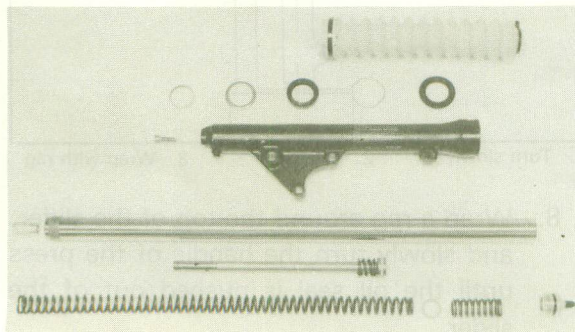

Inspection

1. Examine fork inner tube for scratches and straightness. If the tube is severely scratched or bent, it should be replaced.

WARNING: _____

Do not attempt to straighten a fork tube, since this may weaken the part dangerously.

2. Inspect the slide metal. If damaged or excessively worn, replace it.
3. Check the seal outer seat. If leakage is from this area, replace the seal. If this does not cure the leakage, replace the outer tube.
4. Check the outer tube for dents. If any dent causes the inner tube to "hang up" during operation, the outer tube should be replaced.
5. Check the free length of the springs.

Fork spring free length:

Short spring: 65.8 mm (2.6 in)

Long spring: 539.8 mm (21.3 in)

6. Check the O-ring on the cap bolt. If damaged, replace it.
7. Inspect the damper rod seal and inner tube slide bushing. If damaged or excessively worn, replace them.

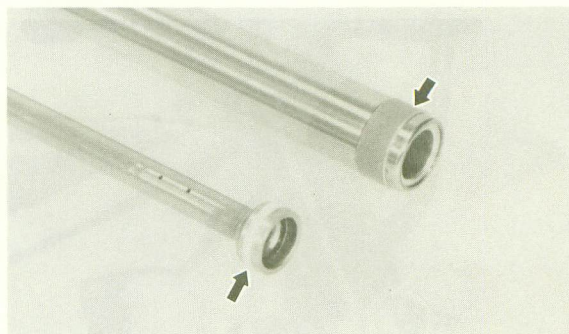

Assembly

1. Make sure all components are clean before assembly. Always install a new fork seal. Do not re-use a seal.
2. Apply LOCTITE® to the threads of the damper rod bolt, and reinstall the bolt.

NOTE: _____

Apply LOCTITE® to the five threads from the bolt head side. Be careful not to apply excessively.

3. Using the damping-cylinder holding tool, torque the damper rod bolt to specification.

Damper rod bolt torque.
20 Nm (2.0 m·kg, 14 ft·lb)

4. Install the slide metal using the special fork tool.

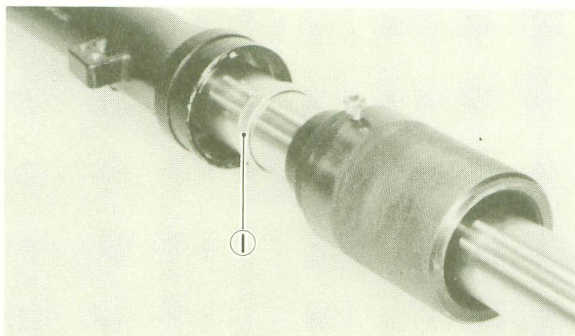

1. Slide metal

5. Install a new seal washer, making sure the beveled edge faces upward.
6. Oil and install a new oil seal with the special tool.

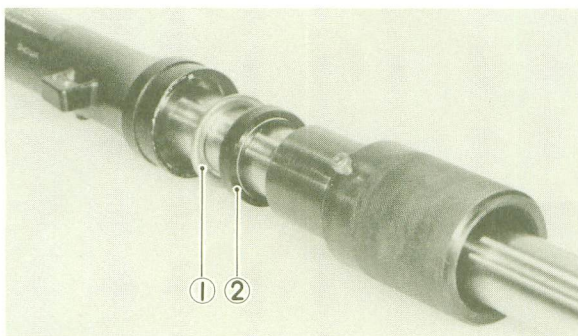

1. Oil seal washer 2. Oil seal

7. Install the snap ring. Gently tap the dust seal into place with the special tool.

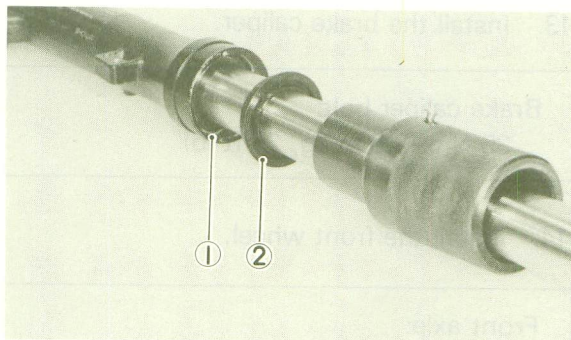

1. Snap ring 2. Dust seal

8. Pour the specified amount of recommended fork oil into the inner fork tube.

Recommended oil:
Oil capacity:
334 cm³ (11.8 Imp oz, 11.3 US oz)
Fork oil 10 wt or SAE #10 fork oil

9. After filling, slowly pump the outer tubes up and down to distribute the oil.
10. Install the long spring, washer, short spring, and the cap bolt.
11. Fill the air and set it to specification. Install the air valve cap.
12. Install the fork assembly into the under bracket and steering crown, and torque the pinch bolts to specification.

Pinch bolt torque:
Steering crown
40 Nm (4.0 m·kg, 29 ft·lb)
Under bracket
20 Nm (2.0 m·kg, 14 ft·lb)

NOTE: _____

Be sure the inner tube mark is aligned with the top of steering crown.

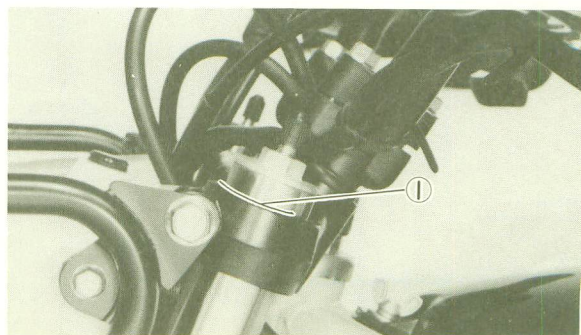

1. Inner tube mark

13. Install the brake caliper.

Brake caliper bolt:
35 Nm (3.5 m·kg, 25 ft·lb)

14. Install the front wheel.

Front axle:
58 Nm (5.8 m·kg, 42 ft·lb)
Pinch bolt:
20 Nm (2.0 m·kg, 14 ft·lb)

STEERING HEAD

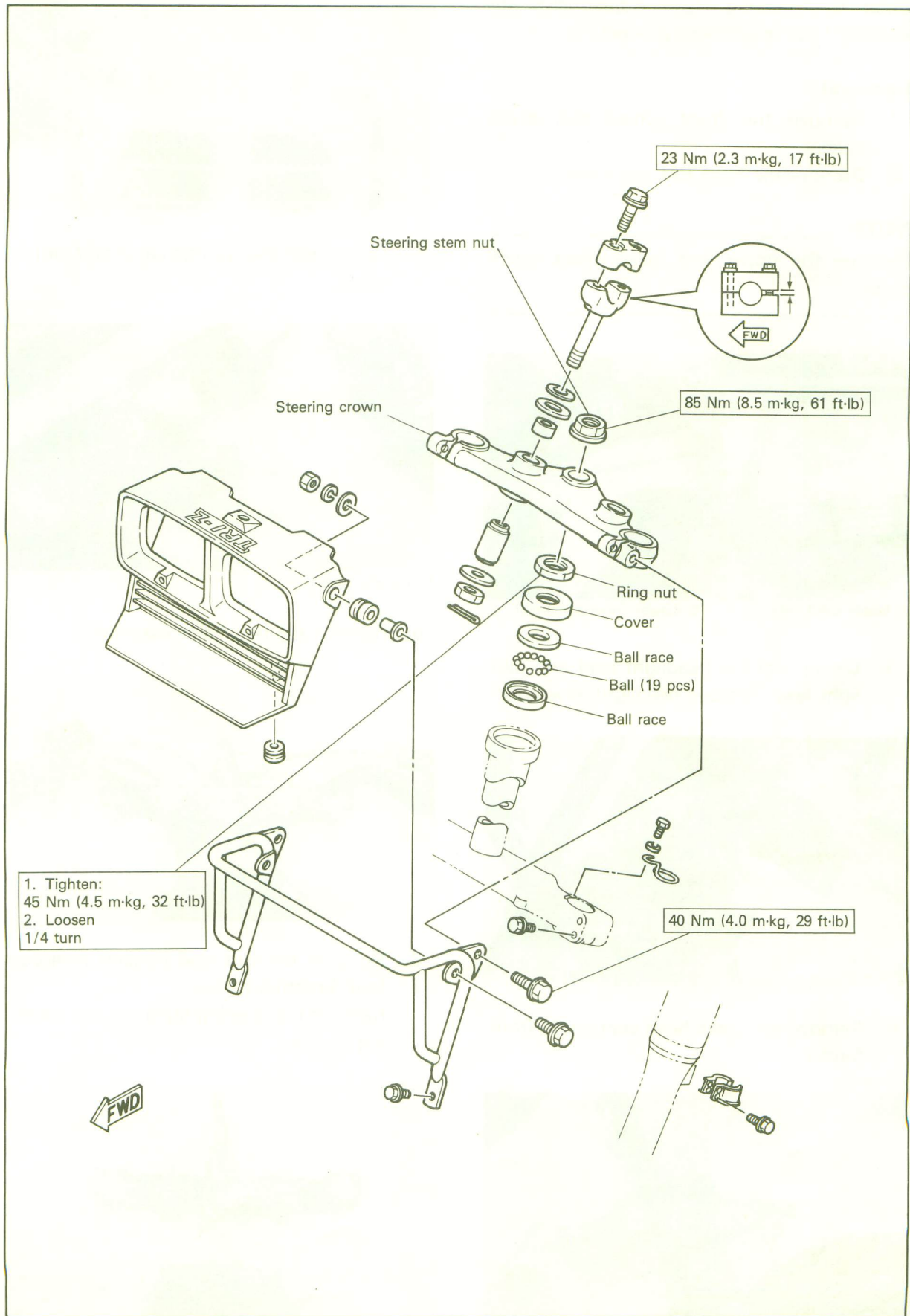

Adjustment

Refer to "Steering Head Adjustment" for steering head adjustment procedures.

Removal

1. Remove the front wheel and brake caliper.
2. Remove the front fork assembly.

NOTE:

Remove the upper and lower-upper pinch bolts.

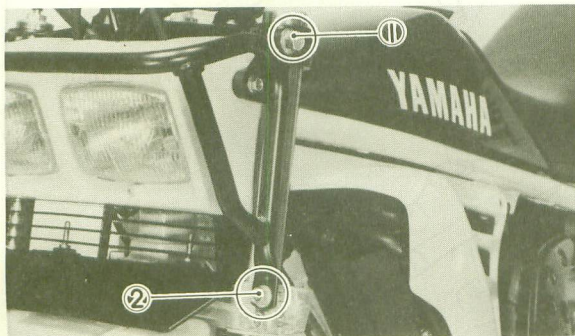

1. Upper pinch bolt 2. Lower-upper pinch bolt

3. Disconnect the headlight lead and pilot light lead. Remove headlight assembly.

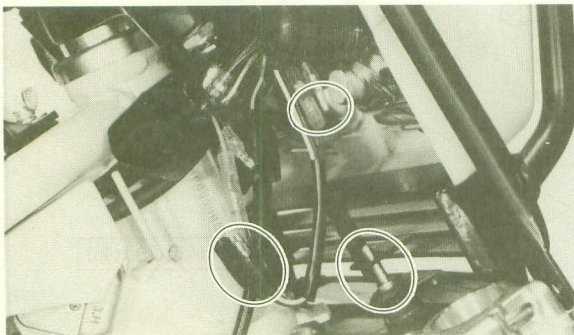

4. Remove the brake hose clamp and front fender.

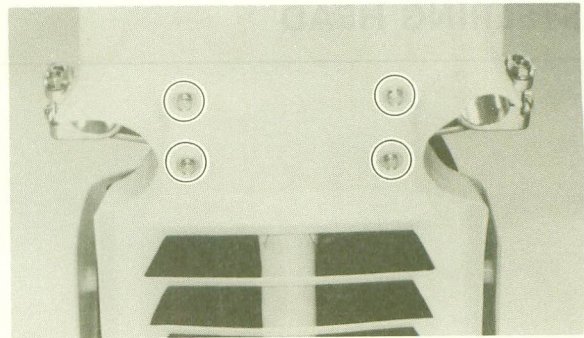
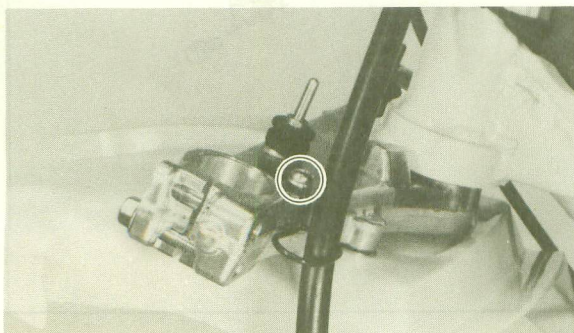

5. Disconnect the throttle cable and clutch cable.

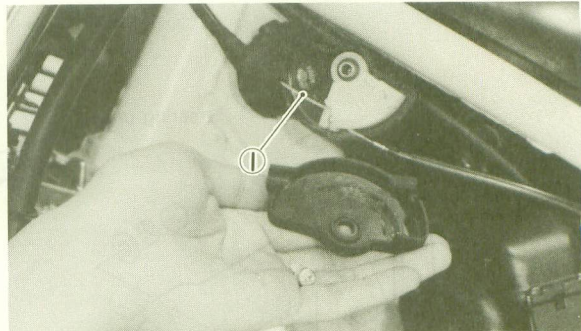

1. Throttle cable

6. Remove the handlebar assembly.

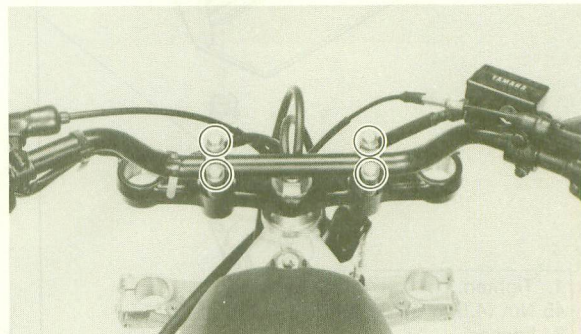

7. Remove the fuel and coolant reservoir tank breather hoses. Remove the steering stem nut and steering crown.

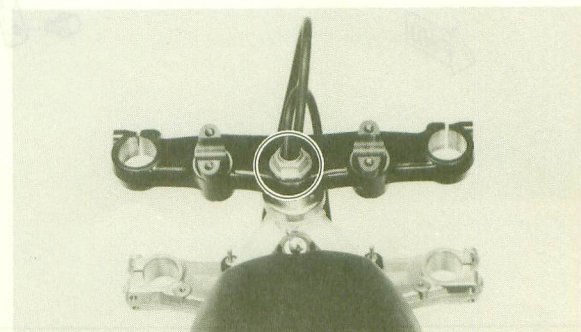

- Support the steering stem, and remove the ring nut, ball race cover, ball race, and balls.

Ball quantity:
Upper: 19 pcs (1/4 in)

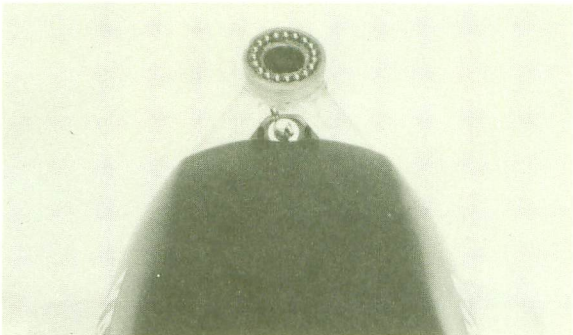
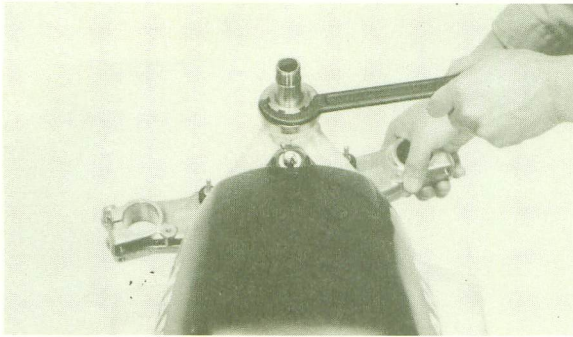

Inspection

Examine all the balls for pits or partial flatness. If any one is found defective, the entire set (including both races) should be replaced. If either race is pitted, shows rust spots, or is damaged in any way, replace both races and all balls.

Installation

- If pressed-in races have been removed, tap in new races.
- Grease the lower bearing of the under bracket.

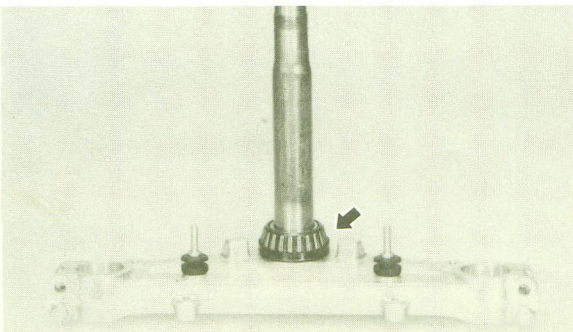

- Grease the lower ball race of the upper bearing and arrange the balls around it. Then apply more grease and set the top race into place.

NOTE:

Use medium-weight wheel bearing grease of quality manufacture, preferably waterproof.

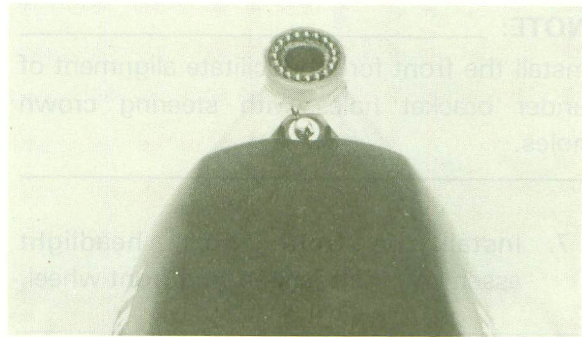

- Carefully slip the under bracket stem up into the steering head. Hold the top bearing assembly in place so the stem does not knock any balls out of position.
- Set the upper bearing cover on and install the ring nut. Tighten the ring nut approximately 45 Nm (4.5 m·kg, 32 ft·lb) and loosen it approximately 1/4 turn. Recheck for free play after the entire fork unit has been installed.

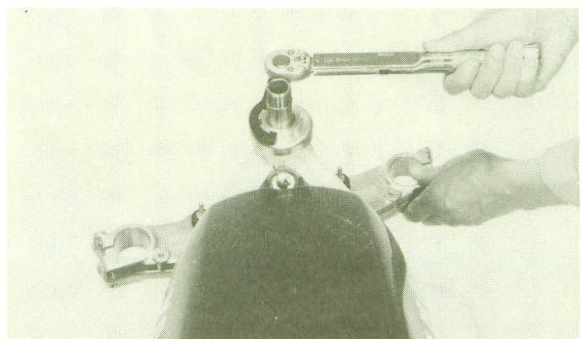

- Install steering crown and tighten steering stem nut.

Steering stem nut:
85 Nm (8.5 m·kg, 61 ft·lb)

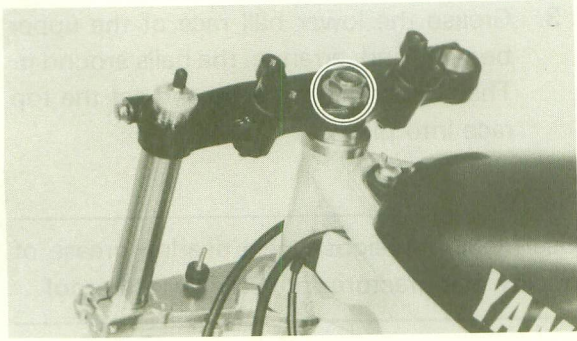

NOTE: _____

Install the front fork to facilitate alignment of under bracket holes with steering crown holes.

7. Install the front forks, headlight assembly, front fender, and front wheel.

TIGHTENING TORQUE:

Steering crown & inner tube:

40 Nm (4.0 m·kg, 29 ft·lb)

Under bracket & inner tube:

20 Nm (2.0 m·kg, 14 ft·lb)

Handlebars upper holder:

23 Nm (2.3 m·kg, 17 ft·lb)

Rear Shock Setting

Spring preload (Installed length)

STD: 235 mm (9.25 in)
 MIN: 220.5 mm (8.68 in)
 MAX: 235.5 mm (9.27 in)

The length of the spring (installed) changes 1 mm (0.04 in) per turn of the adjuster.

CAUTION:

Never attempt to turn the adjuster beyond the maximum or minimum setting.

TIGHTENING TORQUE:
 69 Nm (6.9 m·kg, 50 ft·lb)

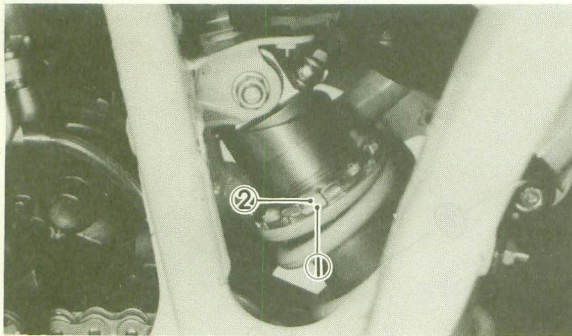

1. Adjuster 2. Locknut

Rebound damping

STD SETTING: 5 clicks out

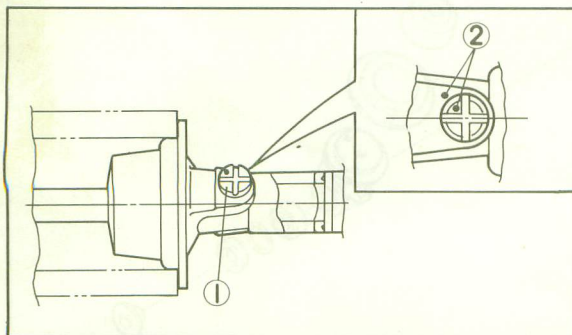

1. Rebound damping adjuster 2. Match marks

CAUTION:

Don't turn out the adjuster more than 25 clicks from the stiffest position.

Compression damping

STD SETTING: 10 clicks in

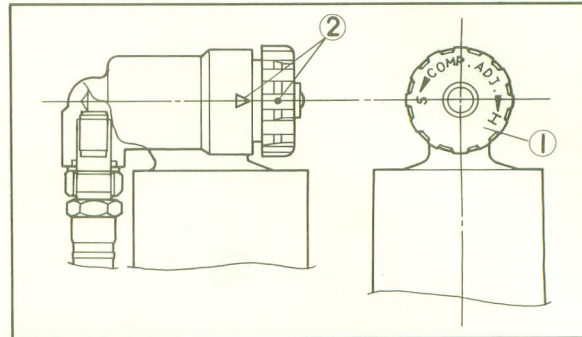

1. Compression damping adjuster 2. Match marks

CAUTION:

Don't turn out the adjuster more than 20 clicks from the softest position.

WARNING:

The compression damping adjuster is very hot immediately after a run. Never allow your bare hand or part of your body to touch it.

Shock spring

Type	Spring rate (kg/mm)	Part number	I.D. color
STD	6.0	38W-22212-00	—
SOFT	5.5	38W-22212-10	Green
HARD	6.5	38W-22212-20	white

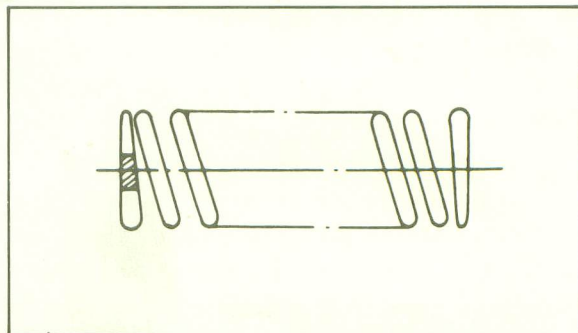

Nitrogen gas pressure

STD: 1.777 kPa (12 kg/cm², 171 psi)
 MIN: 686 kPa (7 kg/cm², 100 psi)
 MAX: 1.480 kPa (15 kg/cm², 213 psi)

Handling Notes

WARNING:

This shock absorber is provided with a separate type tank filled with high-pressure nitrogen gas. To prevent the danger of explosion, read and understand the following information before handling the shock absorber.

The manufacturer can not be held responsible for property damage or personal injury that may result from improper handling.

1. Never tamper or attempt to disassemble the cylinder or the tank. Never tamper with the nut securing the hose to the cylinder assembly; otherwise, oil will spurt from the cylinder due to the high pressure in the nitrogen gas tank.
2. Never throw the shock absorber into an open flame or other high heat. The shock absorber may explode as a result of nitrogen gas expansion and/or damage to the hose.
3. Be careful not to damage any part of the gas tank. A damaged gas tank will impair the damping performance or cause a malfunction.
4. Use care not to damage any part of the hose. Any brake in the hose may result in a spurt of oil under high-pressure.
5. Take care not to scratch the contact surface of the piston rod with the cylinder; or oil could leak out.
6. Never attempt to remove the plug at the bottom of the nitrogen gas tank. It is very dangerous to remove the plug.
7. Never attempt to remove the banjo bolts where the hose attaches to the monoshock and sub tank.
8. When scrapping the shock absorber, follow the instructions on disposal.
9. Don't use on this machine any suspension whose free length exceeds 342 mm (13.46 in). Such unit causes malfunctioning suspension.

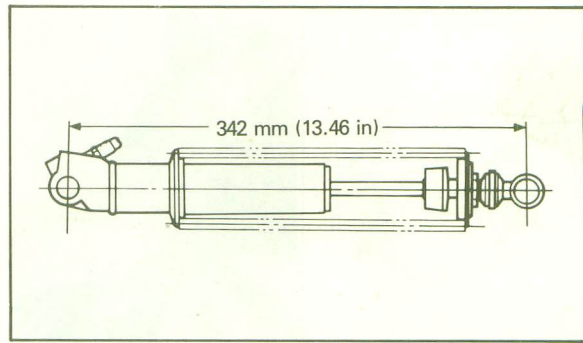

Notes on Disposal (Yamaha dealers only)

Before disposing the shock absorber, be sure to extract the nitrogen gas. To do so, drill a 2 or 3 mm (0.08 ~ 0.12 in) hole through the tank at a position 25 ~ 30 mm (1.0 ~ 1.2 in) from the bottom end of the tank. At this time, wear eye protection to prevent eye damage from escaping gas and/or metal chips.

WARNING:

To dispose of a damaged or worn-out shock absorber, take the unit to your Yamaha dealer for this disposal procedure.

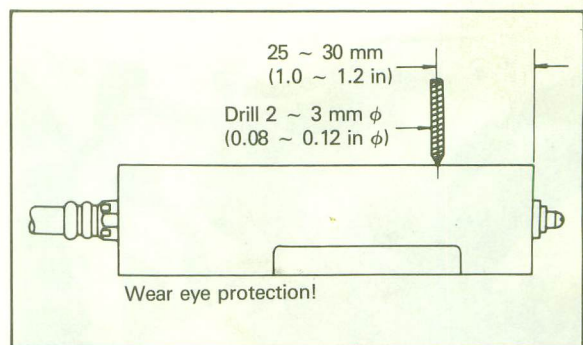

Removal

1. To remove the shock absorber, place the machine on a suitable stand to keep the machine stable while the shock absorber is removed.
2. Remove the seat and rear fender.

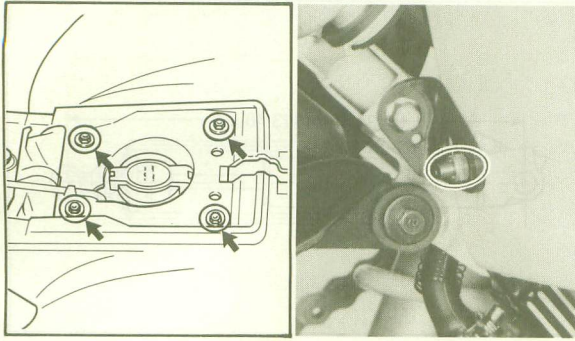

3. Remove the upper connecting rod and lower shockabsorber securing bolts.

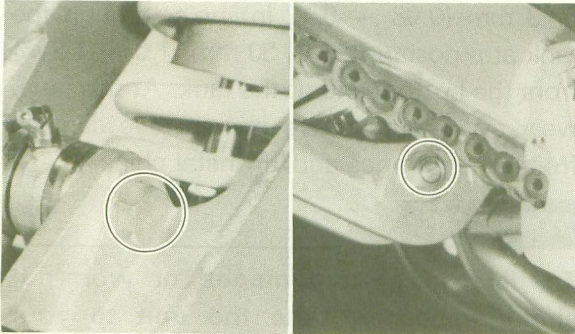

4. Remove the upper shockabsorber securing bolt and shockabsorber reservoir.

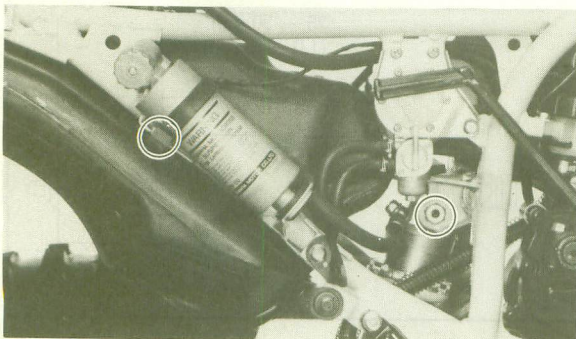

5. Remove the rear shockabsorber assembly.
Push down the spring, remove the spring retainer, and remove the spring.

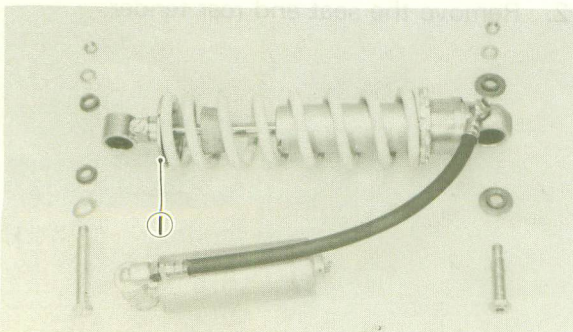

1. Retainer

Installation

1. Install the spring and spring retainer.
2. Tighten the locknut.

TIGHTENING TORQUE:

69 Nm (6.9 m·kg, 50 ft·lb)

3. Apply grease to the collars, bushings, and oil seals.
4. Install the shockabsorber assembly.

Upper bolt:

32 Nm (3.2 m·kg, 23 ft·lb)

Lower bolt:

32 Nm (3.2 m·kg, 23 ft·lb)

Upper connecting rod:

48 Nm (4.8 m·kg, 35 ft·lb)

5. After installing, make sure all these parts move smoothly.

SWINGARM

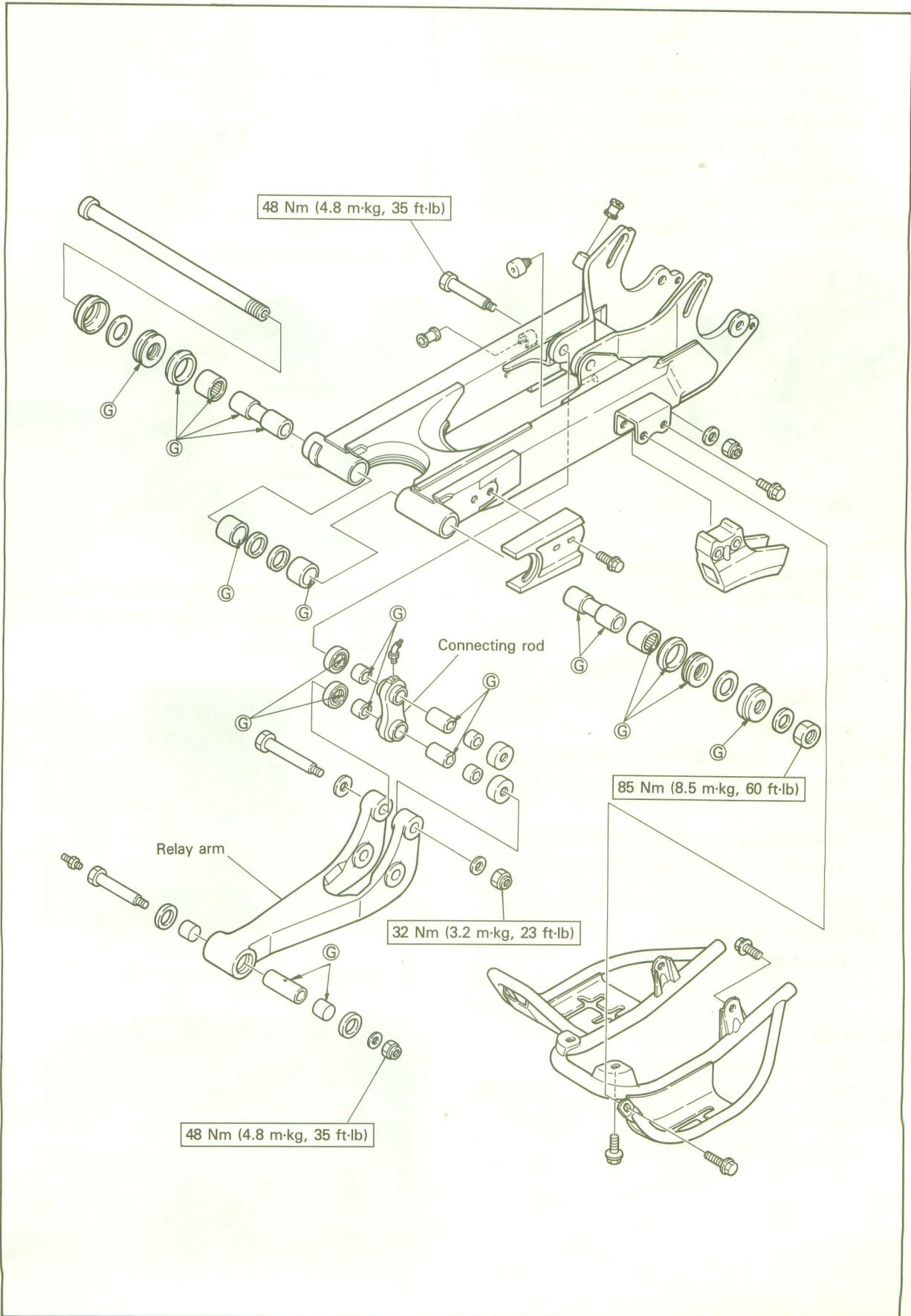

Swingarm Free Play Inspection

1. To check the swingarm bearings, remove the rear wheel, rear axle and brake caliper. Disconnect the shockabsorber from the relay arm and swingarm.
2. Grasp the ends of the swingarm and try to move the arm sideways; if the free play exceeds tolerance, remove the swingarm and take it to your Yamaha dealer for bearing replacement.

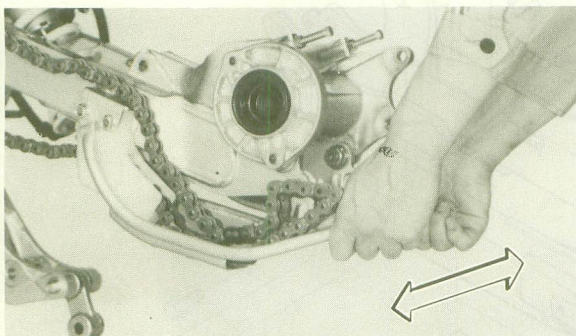

Std swingarm side clearance:
0.2~0.3 mm (0.00757~0.0118 in)

3. Closely inspect the swingarm for cracks or other damage, and repair or replace it as required.
4. When reinstalling the swingarm, be sure to grease the bearings, bushings, and oil seal lips.
5. Grease the pivot shaft, install it and its nut, and torque the nut to specification.

Pivot shaft nut torque:
85 Nm (8.5 m·kg, 60 ft·lb)

Removal

1. Remove the rear wheel assembly.
2. Remove the rear axle ring nuts: Use with the ring nut wrench.
Apply the rear brake.

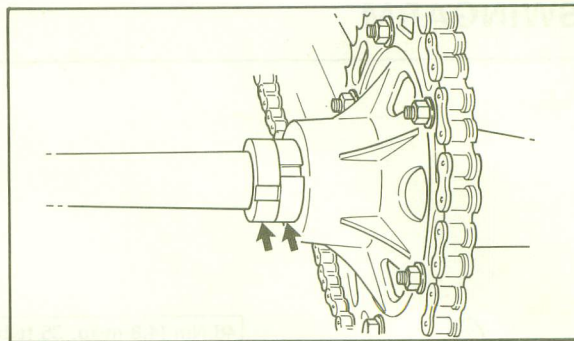

3. Remove the rear brake caliper.

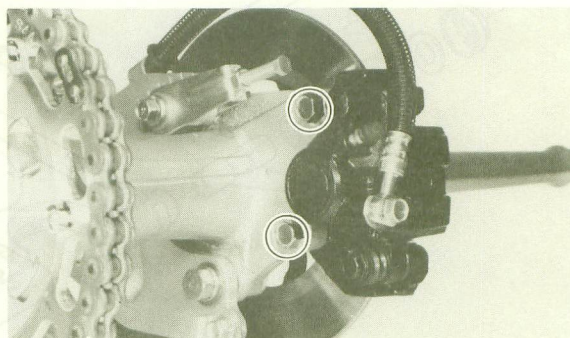

4. Remove the rear axle from the rear wheel hub by tapping the left end axle with a plastic hammer.

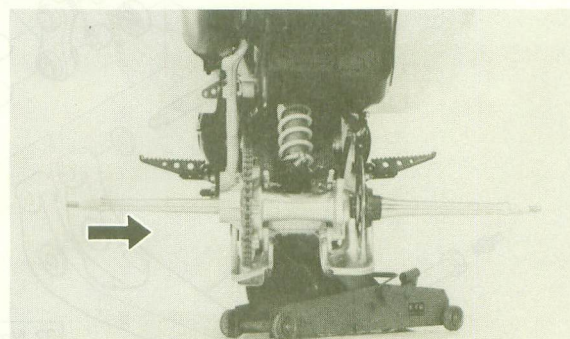

5. Remove the rear wheel hub.

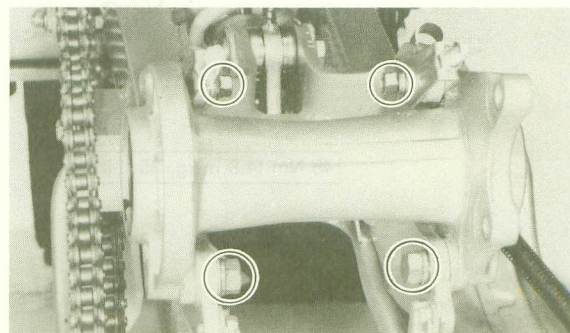

- Remove the upper connecting rod and lower shockabsorber securing bolts.

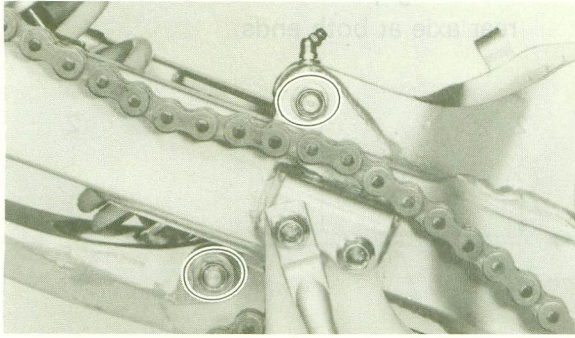

- Remove the chain guard assembly.

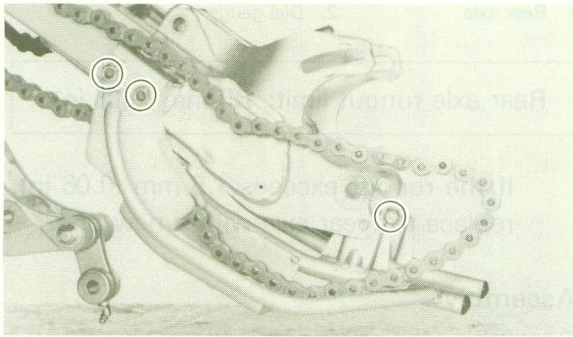

- Remove the nut on the swingarm pivot shaft and tap out the shaft with a long aluminum or brass rod.

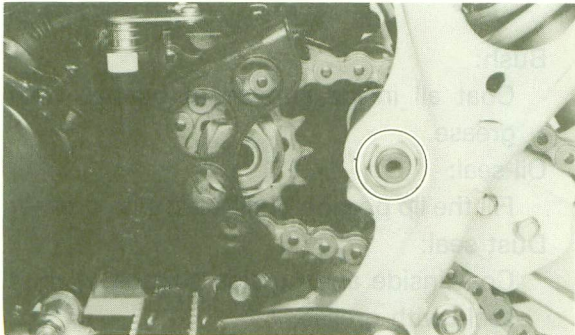

NOTE: _____

Carefully remove the arm while noting the location of spacing washers and shims. They must be reinstalled in the same positions.

- Remove the relay arm and the connecting rod.

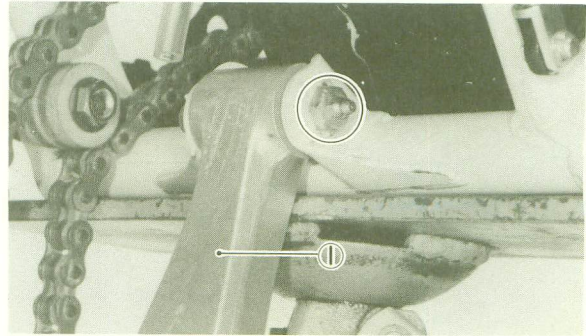

1. Relay arm

Inspection

- Measure the swingarm side clearance.

Std swingarm side clearance:
0.2 ~ 0.3 mm (0.00787 ~ 0.0118 in)

If the swingarm side clearance is out of standard, select the proper shim quantity so that they conform to the standard swingarm side clearance.

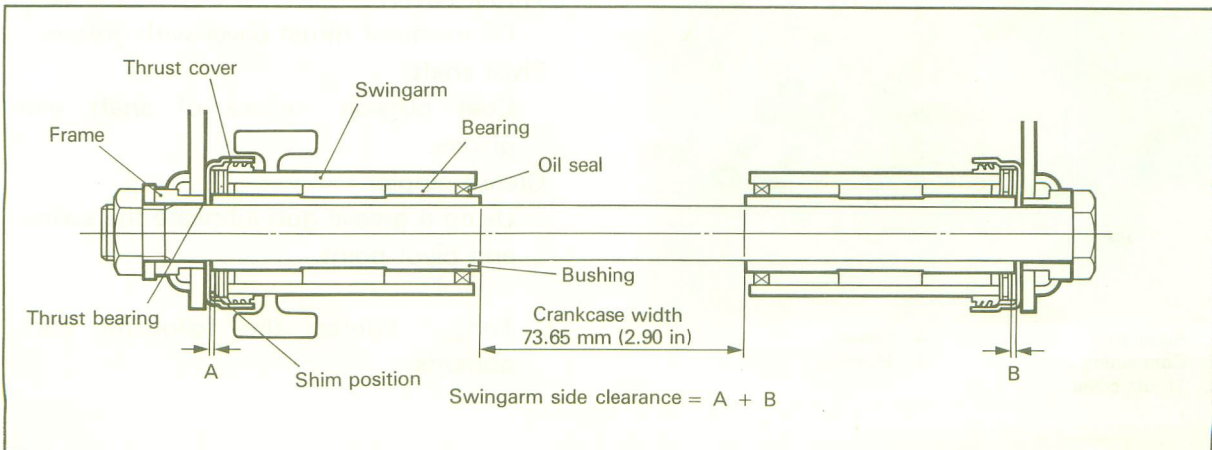

NOTE: _____
 The shim should be installed on the left side only.

2. Check the bushings, bearings and oil seals for scratches and/or damage. Replace if scratched and/or damaged.

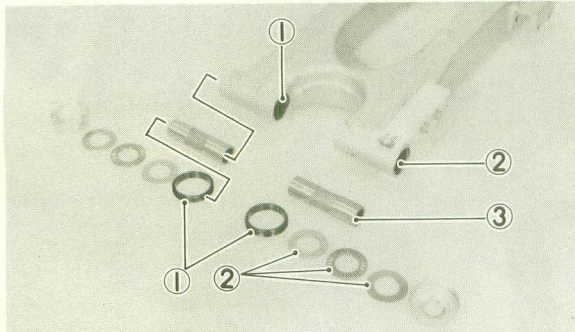

1. Oil seal 2. Bearing 3. Bushing

3. Check the rear wheel hub, bearings and oil seal for damage. Replace if damaged.

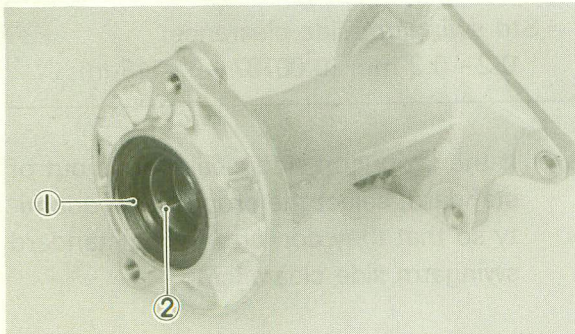

1. Bearing 2. Oil seal

4. Check the relay arm, connecting rod, thrust cover, collar, and bushing for damage. Replace if damaged.

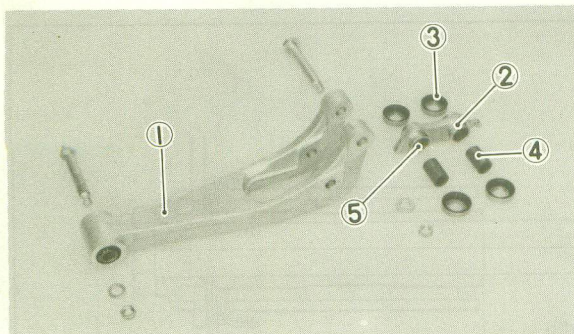

1. Relay arm 4. Collar
 2. Connecting rod 5. Bushing
 3. Thrust cover

5. As shown below, support the rear axle by placing V-blocks under the bearing mounting positions and check for the rear axle at both ends.

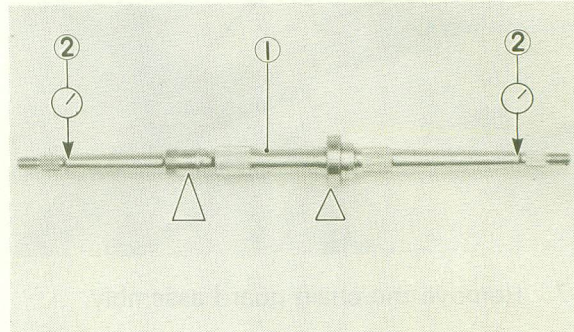

1. Rear axle 2. Dial gauge

Rear axle runout limit: 1.5 mm (0.06 in)

If the runout exceeds 1.5 mm (0.06 in), replace the rear axle with a new one.

Assembly

Assemble the swingarm by reversing the removal procedure. Take care of the following precautions.

1. Apply grease to the portions of the swingarm.

Bush:

Coat all inside surface of bushes with grease.

Oil seal:

Fill the lip portion of oil seals with grease.

Dust seal:

Coat inside and outside surface of dust seals with grease.

Thrust cover:

Fill inside of thrust cover with grease.

Pivot shaft:

Coat outside surface of shaft with grease.

Grease nipple:

Using a grease gun lubricate the swing-arm pivot point.

2. Torque tighten the following components.

- Swingarm-Connecting rod
48 Nm (4.8 m·kg, 35 ft·lb)
- Rear wheel hub - Swingarm
Upper: 50 Nm (5.0 m·kg, 36 ft·lb)
Lower: 80 Nm (8.0 m·kg, 58 ft·lb)
- Brake caliper
35 Nm (3.5 m·kg, 25 ft·lb)
- Rear axle ring nut
133 Nm (13.3 m·kg, 96 ft·lb)
- Rear axle nut
100 Nm (10.0 m·kg, 72 ft·lb)

WARNING:

Always use the new cotter pin on the axle nut.

DRIVE CHAIN

1. Remove the change pedal and drive sprocket cover.

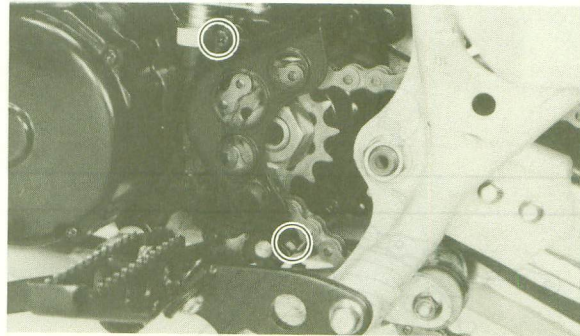

2. Remove the master link clip and disconnect the drive chain.
3. Inspect the teeth on the rear sprocket; if they are worn as shown in the illustrations below, replace the sprockets and chain as a set.

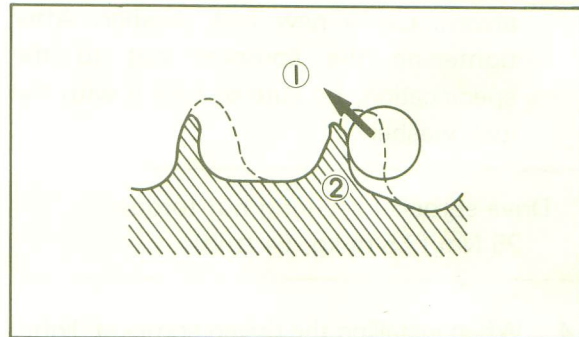

1. Slip off
2. Bend teeth

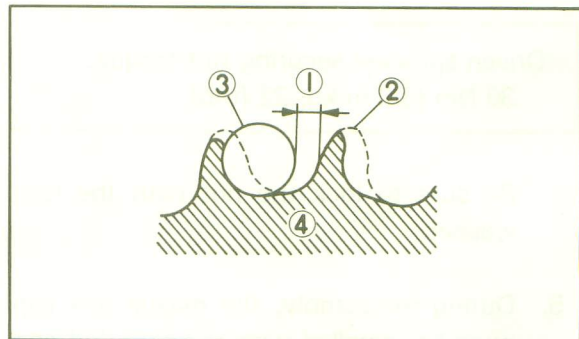

1. 1/4 tooth
2. Correct
3. Roller
4. Sprocket

2. If the chain stays bent or kinked after cleaning and lubrication, or if the chain can be pulled away from the sprocket more than 1/2 the length of a sprocket tooth, the chain and sprockets should be replaced as a set.

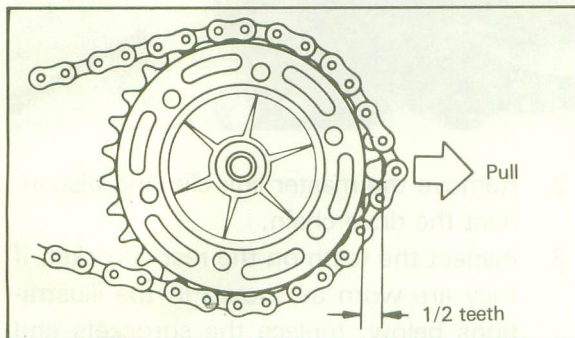
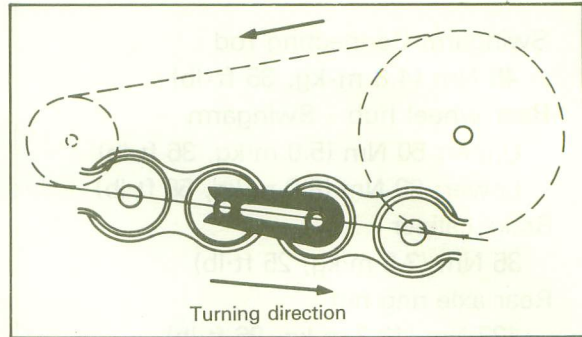
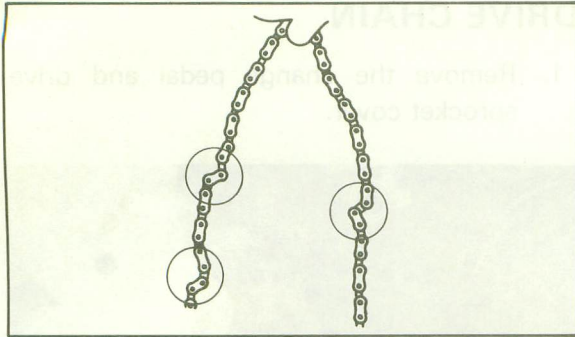

- When replacing the drive sprocket, always use a new lock washer. After tightening the sprocket nut to the specification, be sure to lock it with the lock washer.

Drive sprocket securing nut torque:
75 Nm (7.5 m·kg, 54 ft·lb)

- When installing the driven sprocket, lightly smear grease on the fitting bolts.

Driven sprocket securing nut torque:
30 Nm (3.0 m·kg, 22 ft·lb)

Be sure to lock the nut with the lock washer.

- During reassembly, the master link clip must be installed with the rounded end facing the direction of travel.

NOTE:

The chain should be cleaned and lubricated after every use of the machine.

5 ELECTRICAL TROUBLESHOOTING

YTZ250N WIRING DIAGRAM	5-2
IGNITION SYSTEM	5-3
LIGHTING SYSTEM	5-7
SIGNAL SYSTEM	5-11

5 ELECTRICAL TROUBLESHOOTING

YTZ250N WIRING DIAGRAM

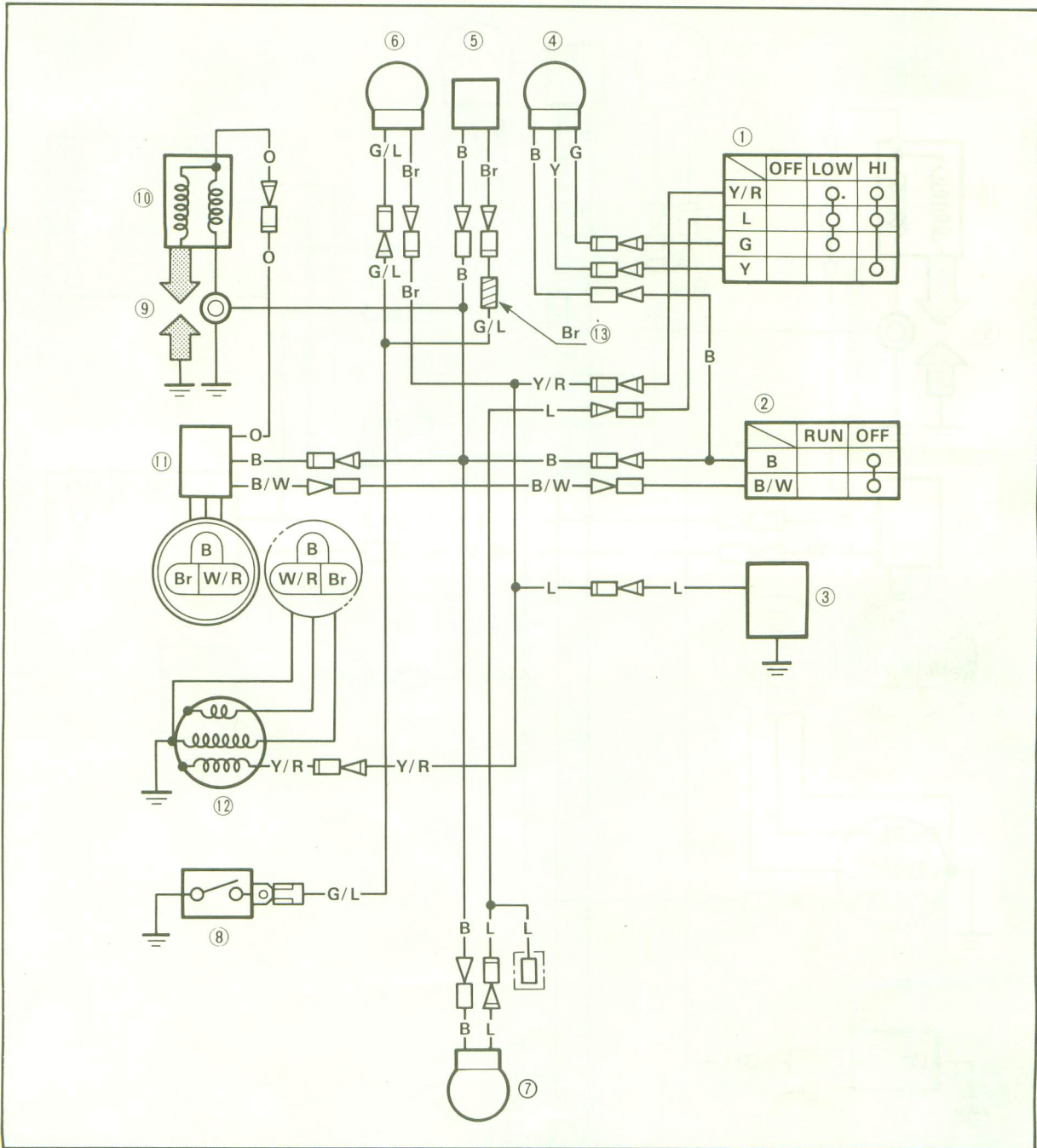

1. Light/Dimmer switch
2. Engine stop switch
3. Voltage regulator
4. Headlight
5. Pilot light checker
6. Pilot light
7. Taillight
8. Thermostatic switch
9. Spark plug
10. Ignition coil
11. CDI Unit
12. CDI Magneto
13. Br-tube

COLOR CODE

W/R	White/Red
B/W	Black/White
B	Black
O	Orange
Br	Brown
Y/R	Yellow/Red
G/L	Green/Blue
Y	Yellow
G	Green

IGNITION SYSTEM

Circuit Diagram

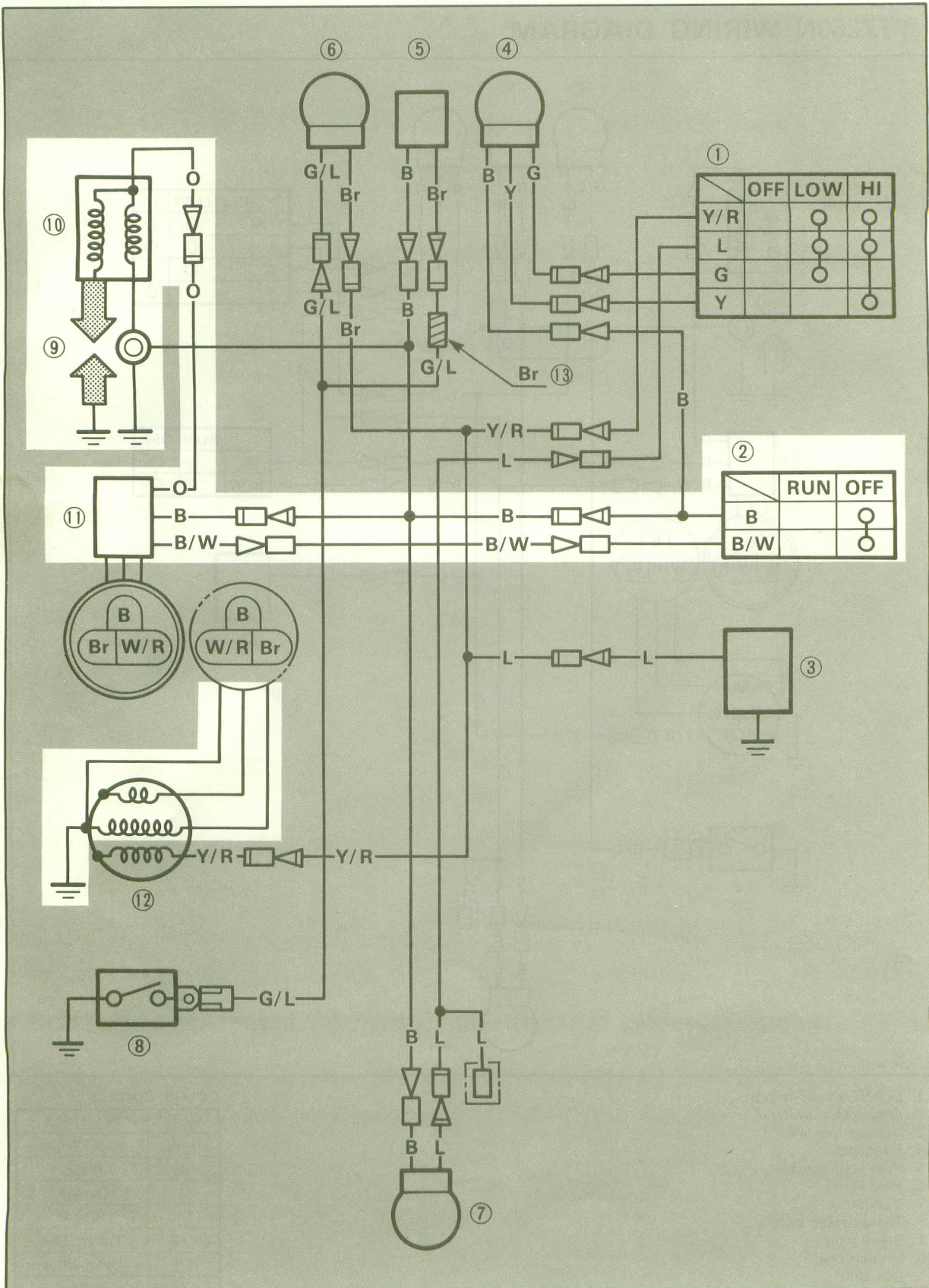

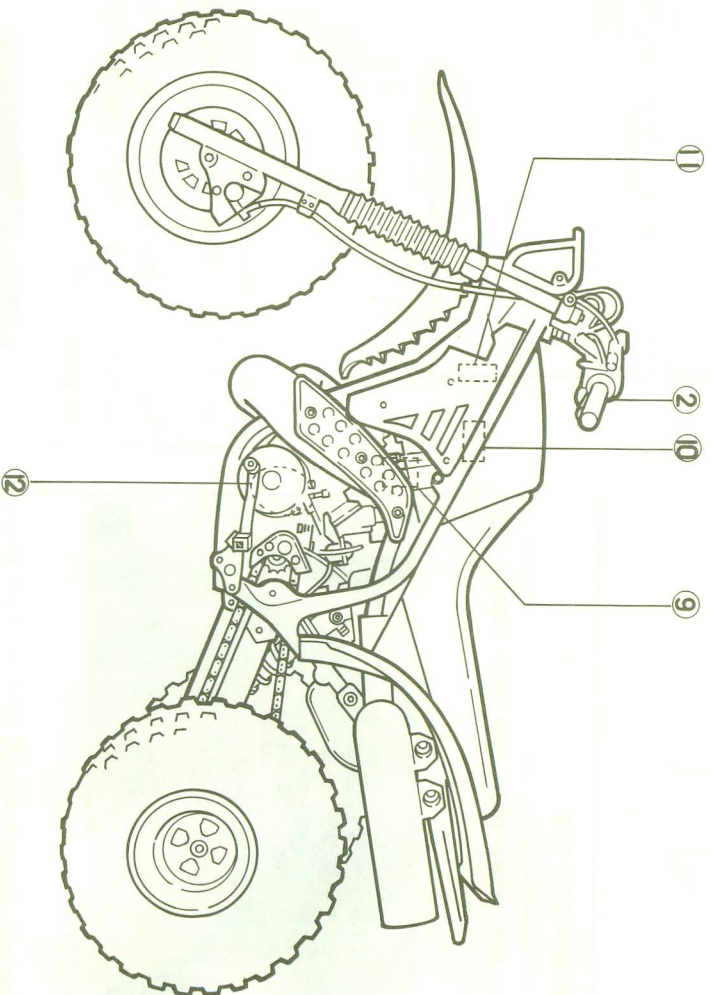

- ② Engine stop switch
- ⑨ Spark plug
- ⑩ Ignition coil
- ⑪ C.D.I. Unit
- ⑫ C.D.I. Magneto

Make sure the wire harness is in a position it will not make contact with exhaust pipe, which could short out C.D.I. unit.

Troubleshooting

If the ignition spark is of poor quality or if there is no spark at all; use the following procedure, to locate and repair the problem.



1	Spark plug test
---	-----------------

Remove the spark plug and check the spark.

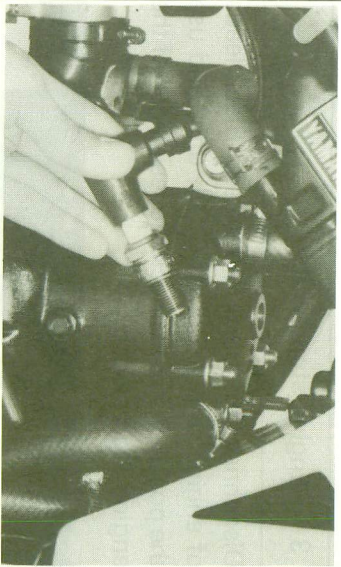

Grounding the spark plug cap to the cylinder head, and kick the starter.

NOTE:

If the spark plug is oily or has carbon deposits, clean it or replace.

No spark

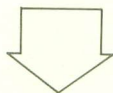

2 Spark gap test

Remove the spark plug cap and check the spark.

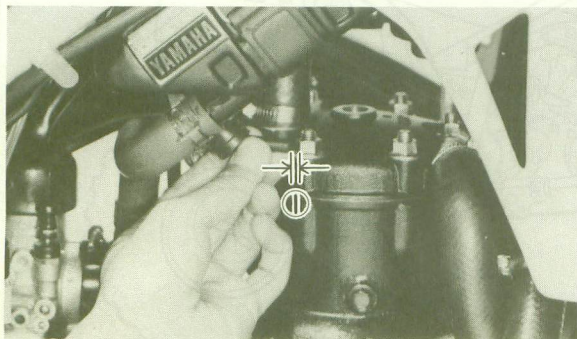

① 5 mm (0.20 in)

Hold the high tension lead 5 mm (0.20 in) from the head, and kick the engine.

Good spark

1. Check plug cap
2. Check spark plug

No spark

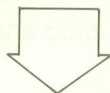

3 Engine stop switch

Disconnect the Black/White and Black leads of engine stop switch at C.D.I. unit, and use the pocket tester to check the resistance of the engine stop switch.

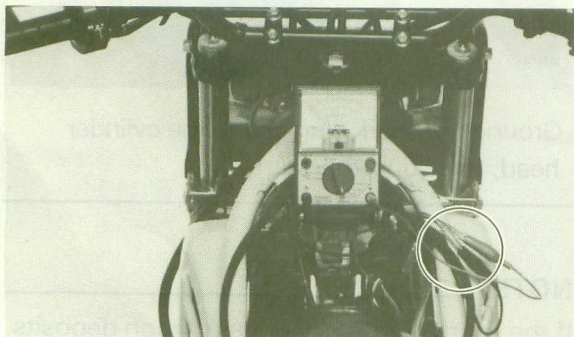

Switch	RUN	OFF
Tester	∞	0Ω

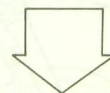
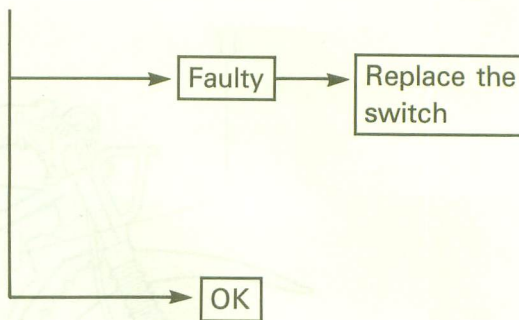

4 C.D.I. Magneto (Source coil) test

Disconnect the magneto leads, and use the pocket tester to check the resistance of the magneto coils.

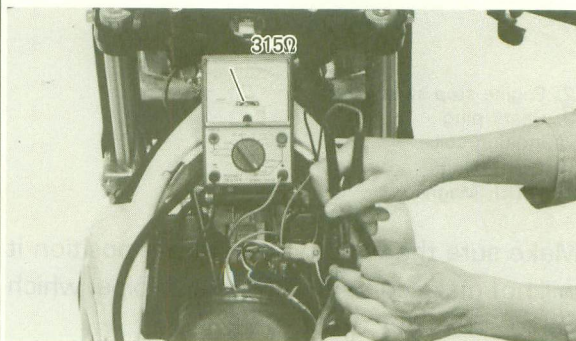

Source coil resistance:
Brown — Black: $315\Omega \pm 10\%$

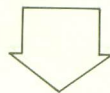
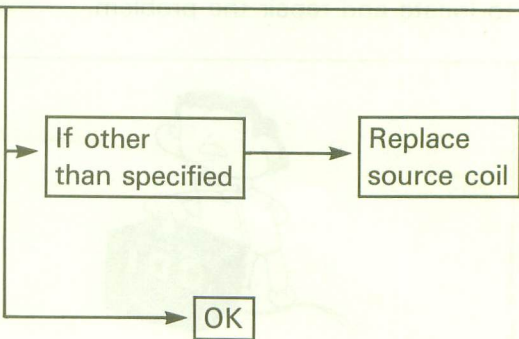

5 C.D.I. Magneto (Pickup coil) test

Disconnect the magneto leads, and use the pocket tester to check the resistance of the pickup coil.

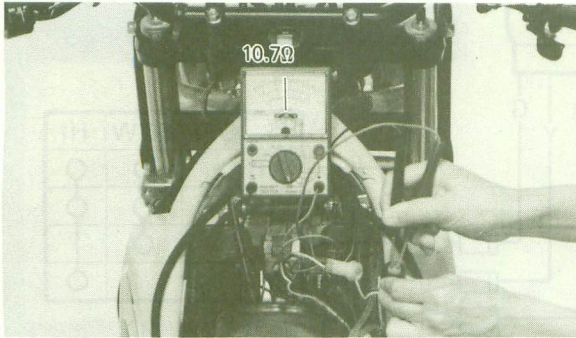

Pickup coil resistance:
White/Red — Black
 $10.7\Omega \pm 10\%$

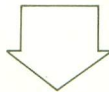
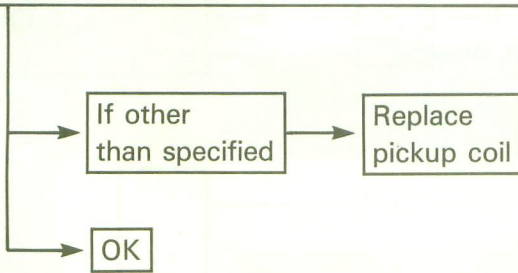

6 Connectors check-up

1. Check the connectors and couplers for looseness of joining ends.
2. Keep the connectors and couplers from dirt or rust.

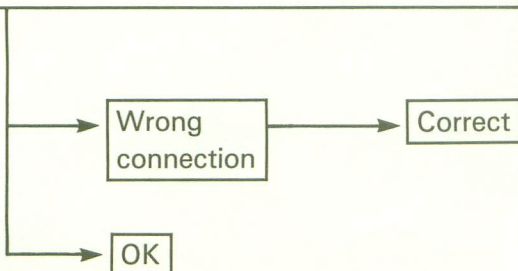

7 Ignition coil test

Use the pocket tester to check the resistance of primary and secondary windings of the ignition coil.

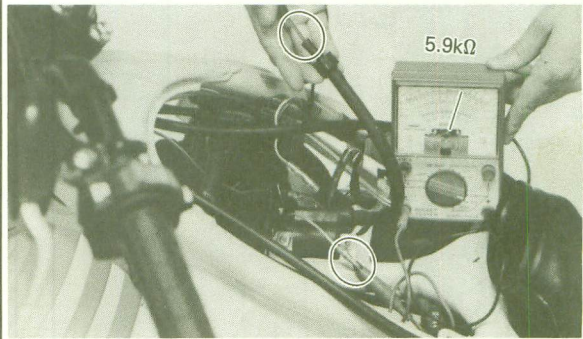
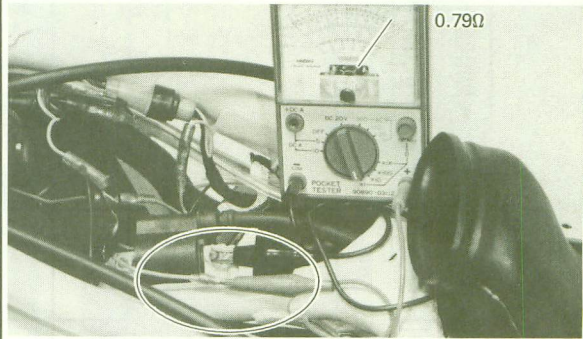

Primary coil resistance:
 $0.79\Omega \pm 15\%$

Secondary coil resistance:
 $5.9k\Omega \pm 15\%$

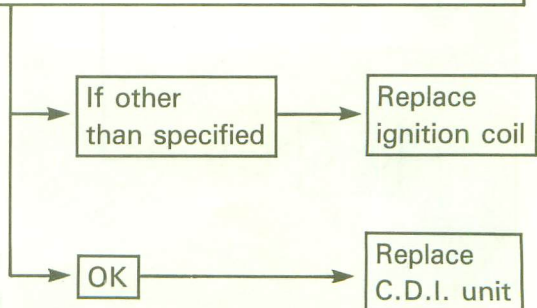

CAUTION:

Make sure the wire harness is in a position it will not make contact with exhaust pipe, which could short out C.D.I. unit.

LIGHTING SYSTEM

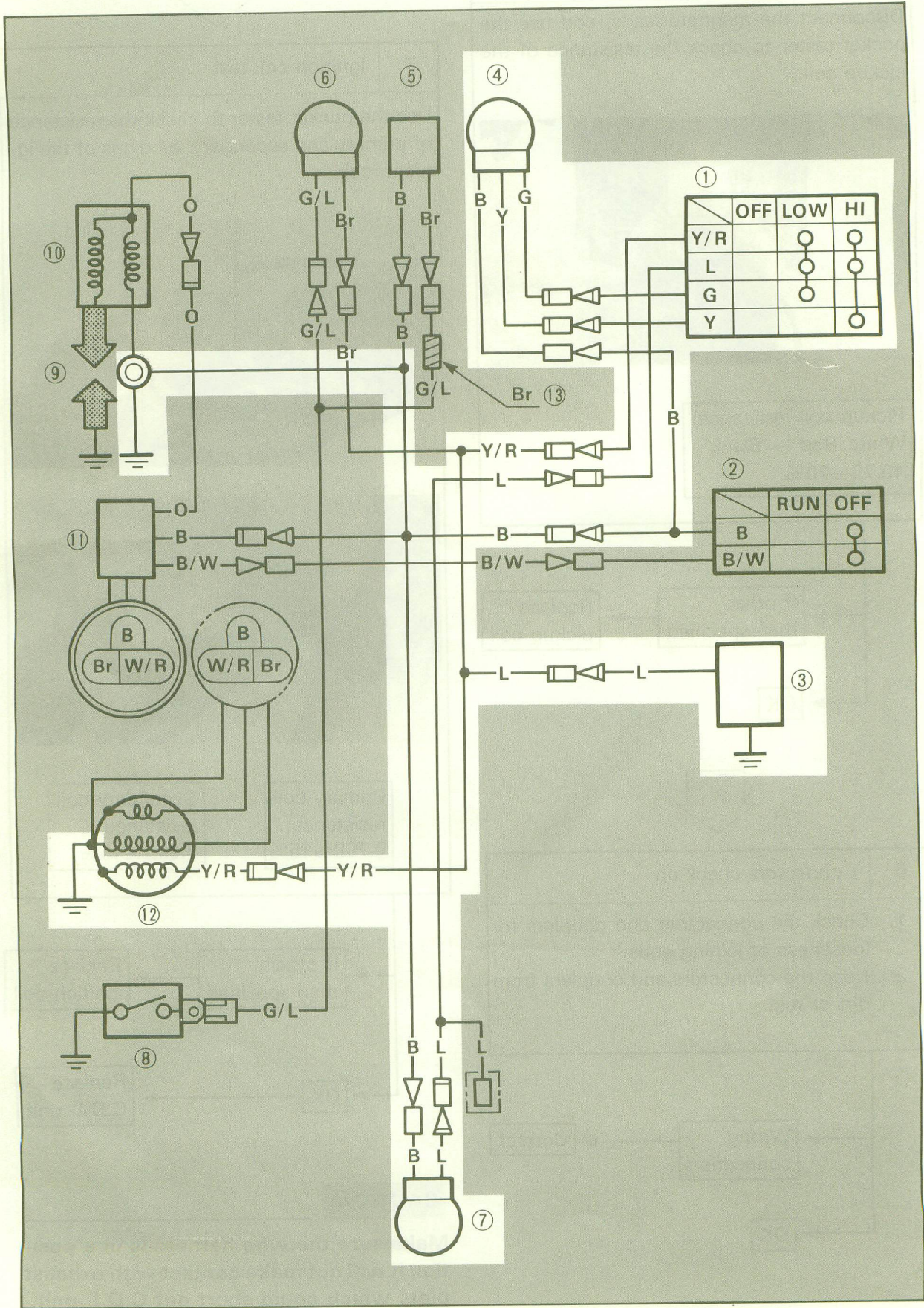

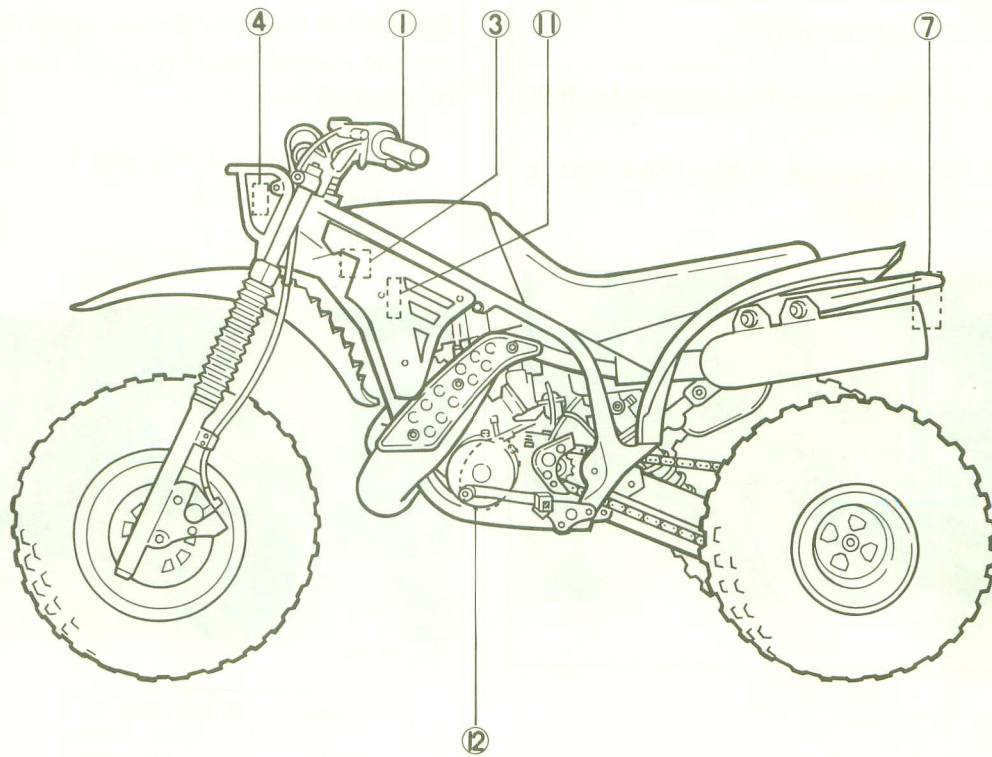

- ① Light/Dimmer switch
- ③ Voltage regulator
- ④ Headlight
- ⑦ Taillight
- ⑫ C.D.I. Magneto

Troubleshooting

Headlight and taillight do not come on when engine is running.

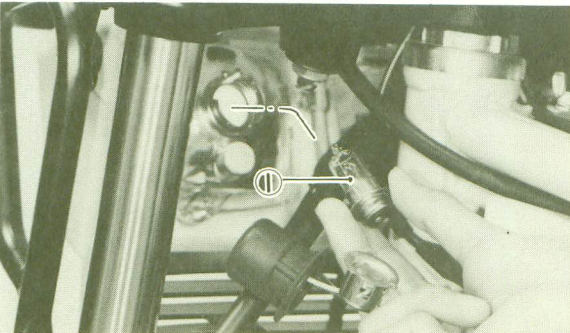
1	Headlight/Taillight bulbs
Remove the headlight and taillight bulb and check the bulb.	
	
① Headlight bulb	

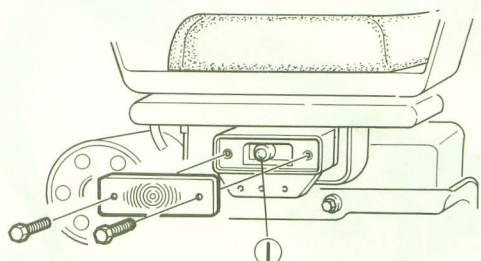

① Taillight bulb

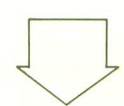
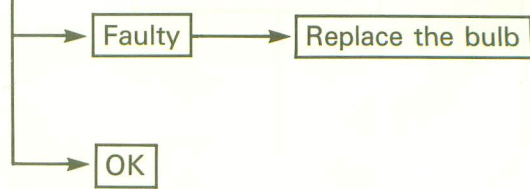

2

Light/Dimmer switch

Start the engine and rev the engine to 1500 rpm.

Measure the voltage on Yellow/Red lead to light/dimmer switch.

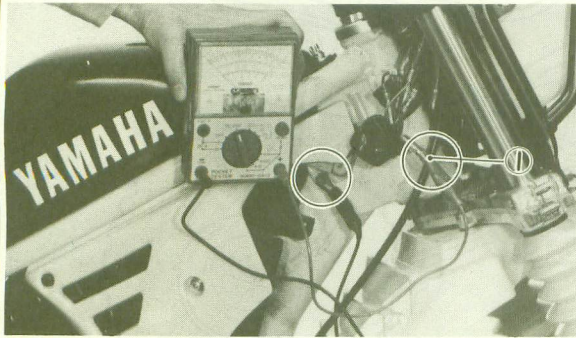

① Yellow/Red lead

More than 12V

Check the voltage regulator and replace if necessary.

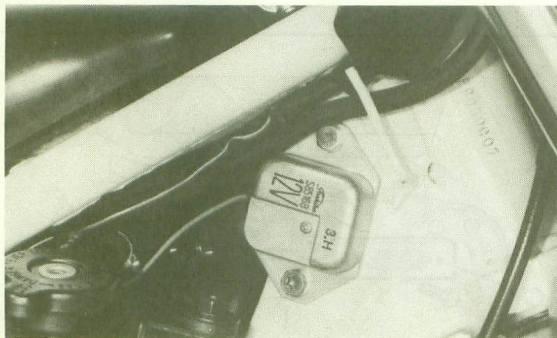

12V and less than

Disconnect the light/dimmer switch leads, and use the pocket tester to check the resistance of the switch.

- OFF: Y/R — L, G, and Y
- LOW: Y/R — G
- HI: Y/R — Y

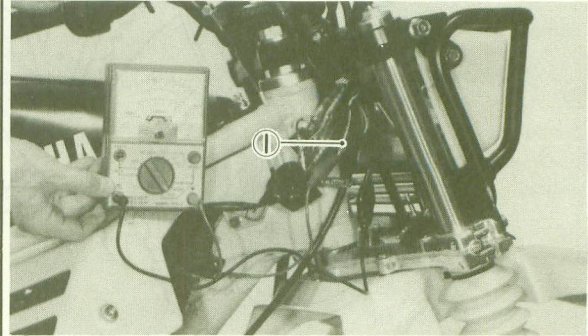

① Y/R lead

Switch	OFF	LOW	HI
Tester	∞	0Ω	0Ω

Faulty

Replace the switch

No Voltage

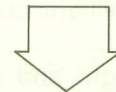

3 C.D.I Magneto (Lighting coil) test

Disconnect the mageto lead, and use the pocket tester to check the resistance of the magneto coil.

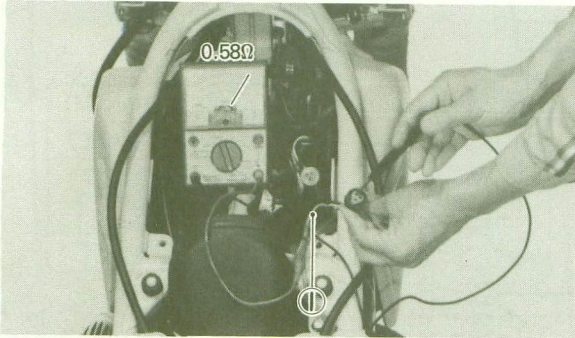

① Y/R lead

Lighting coil resistance:
Yellow/Red-Black: $0.58\Omega \pm 10\%$

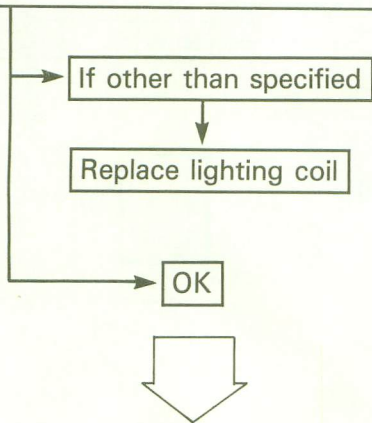

4 Connectors check-up

1. Check the connectors and couplers for looseness of joining ends.
2. Keep the connectors and couplers from dirt or rust.

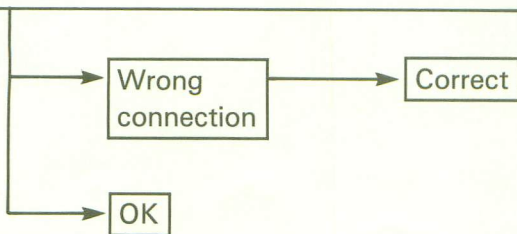

SIGNAL SYSTEM

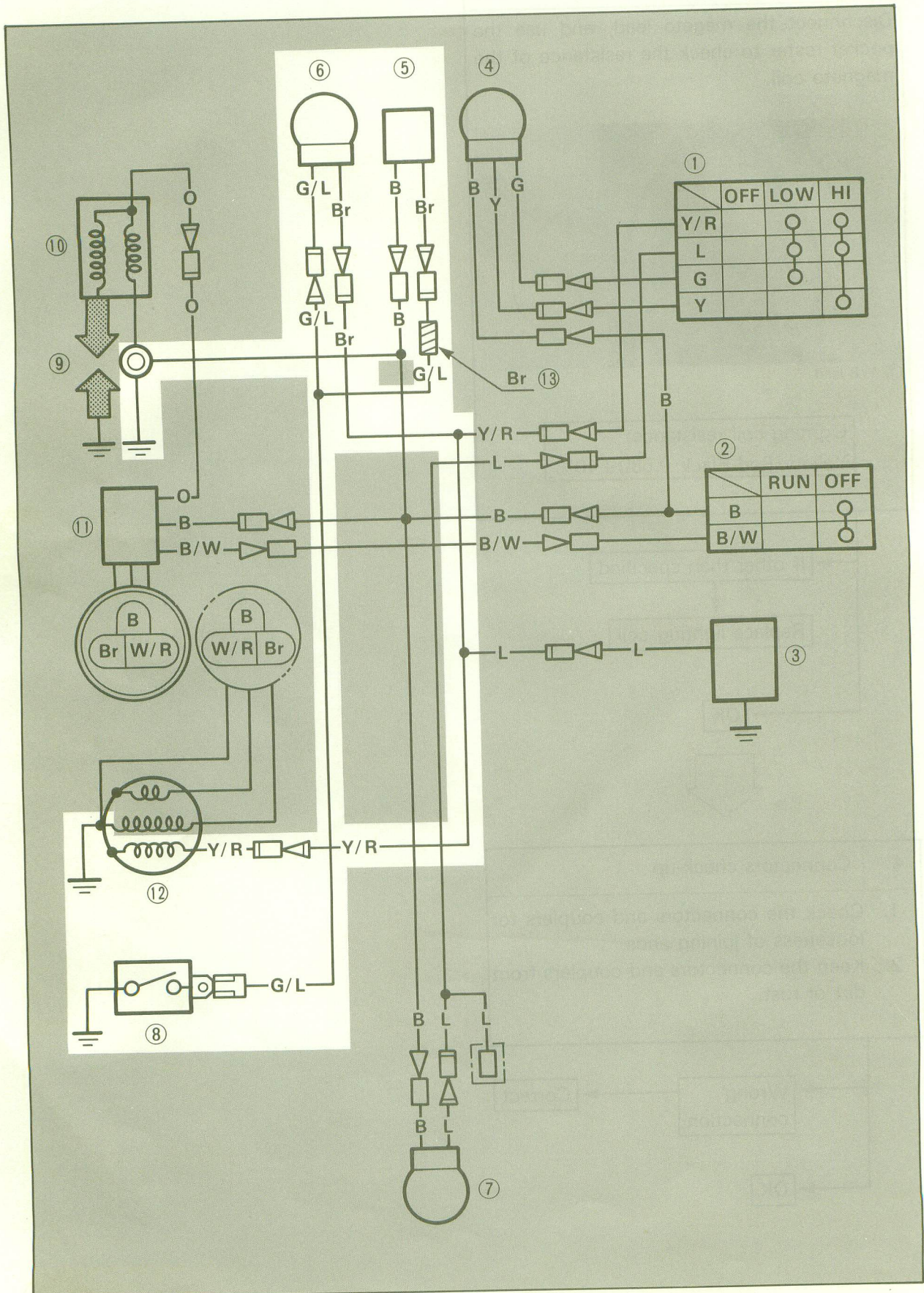

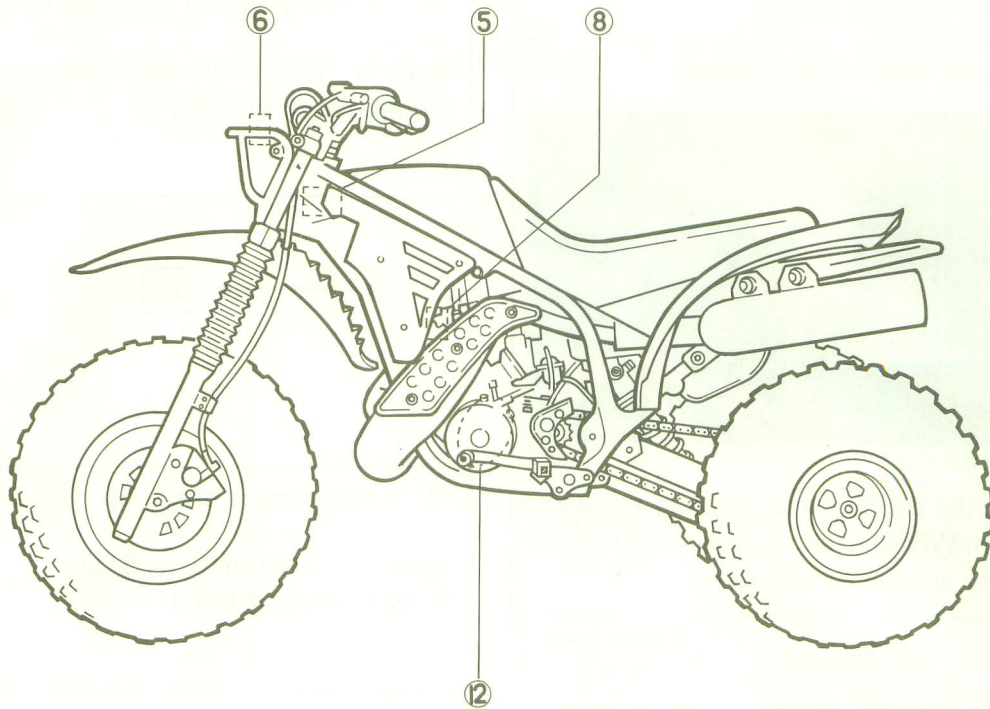

- ⑤ Pilot light checker
- ⑥ Pilot light
- ⑧ Thermostatic switch
- ⑫ C.D.I. magneto

Troubleshooting

The pilot light does not come on:

- For 3 seconds when engine is turned on
- When the coolant temperature is more than 98°C (208.4°F)

1	Pilot bulb
Remove the pilot bulbs and check them.	
① Bulb	

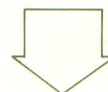
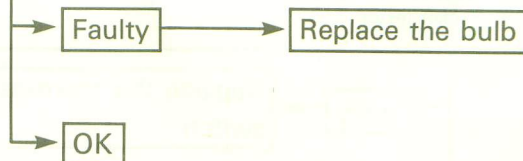

2 Thermostatic switch

Remove the thermostatic switch.

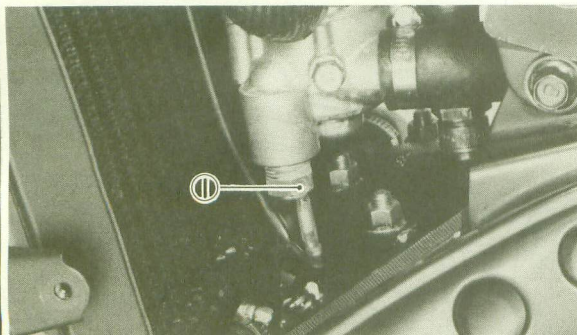

① Thermostatic switch

Immerse the thermostatic switch in the water as shown. While heating the water, check the continuity at each temperature.

Test step	Water temperature	Pocket tester ($\Omega \times 1$)
1	0 ~ 98°C (32 ~ 208.4°F)	Discontinuity
2	more than 105 ± 3°C (more than 221.0 ± 37.4°F)	Continuity
3*	105 to 98°C (221 to 208.4°F)	Continuity
4*	less than 98°C (less than 208.4°F)	Discontinuity

Test 1 & 2; Heat-up tests

Test 3* & 4*; Cool-down tests

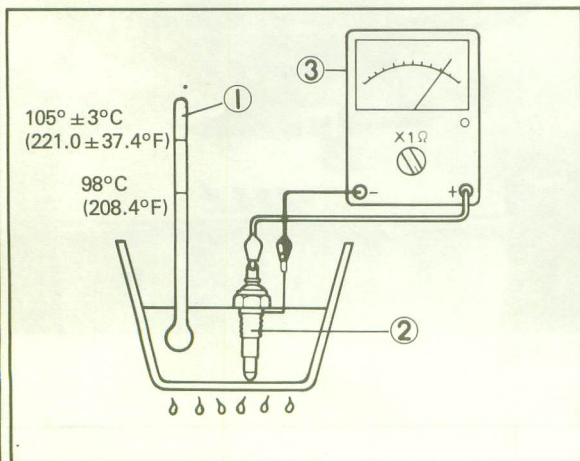

- 1. Temperature gauge
- 2. Thermostatic switch
- 3. Pocket tester

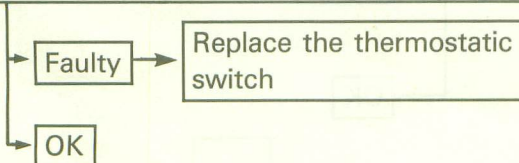

3 C.D.I Magneto (Lighting coil) test

Refer to "LIGHTING SYSTEM Troubleshooting NO.3"

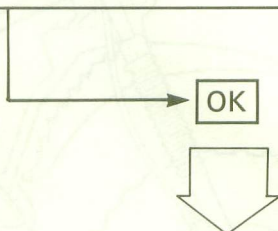

4 Connectors check-up

Refer to "LIGHTING SYSTEM Troubleshooting NO.4"

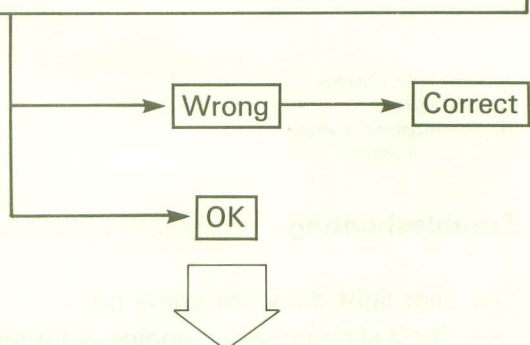

Replace pilot light checker.

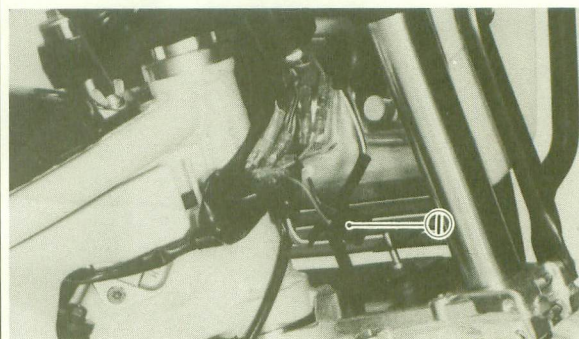

① Pilot light checker

6 APPENDICES

TROUBLESHOOTING GUIDE	6-1
Engine is hard to start or does not start	6-1
Poor high speed performance	6-2
Overheat	6-3
Low coolant level	6-3
Transmission and shifter	6-4
Clutch	6-4
Chassis	6-5
SPECIFICATIONS	6-6
GENERAL TORQUE SPECIFICATION	6-16
DEFINITION OF UNITS	6-16
CONVERSION TABLES	6-17
CABLE ROUTING	6-18
WARRANTY INFORMATION	6-22
NOISE REGULATION	6-23
MAINTENANCE RECORD	6-23

6 APPENDICES

TROUBLESHOOTING GUIDE

Engine is hard to start or does not start.

Ignition System	
Possible Cause	Remedy
<ol style="list-style-type: none"> 1. Spark plug is wet. 2. Ignition coil is faulty. 3. C.D.I. unit is faulty. 4. C.D.I. magneto is faulty (Pulser coil, source coil) 5. Ignition timing is incorrect. 6. Wire is broken, shorted or disconnected. 7. Engine stop switch is shorted. 	<ul style="list-style-type: none"> • Clean or replace • Replace • Replace • Replace • Adjust • Repair, replace or connect • Repair or replace
Compression System	
Possible Cause	Remedy
<ol style="list-style-type: none"> 1. Piston rings are sticking or worn. 2. Cylinder or piston is worn or scratched. 3. Compression leaks passing cylinder head gasket. (Head is distoredted). 4. Crankshaft side oil seal is faulty. 5. Air leaks through crankcase sealing surfaces. 	<ul style="list-style-type: none"> • Replace • Repair or replace • Replace (or repair) • Replace • Repair
Air/Fuel System	
Possible Cause	Remedy
<ol style="list-style-type: none"> 1. Carburetor pilot jet is clogged. 2. Fuel petcock or pipe is clogged. 3. Float valve is faulty. (Float height is too high or too low.) 4. Reed valve is broken or deformed. 5. Fuel tank filler cap or carburetor brather pipe is clogged. 6. Air screw is improperly adjusted. 7. Fuel is deteriorated. 8. Oil-gas mixing ratio is incorrect. 9. Air leakes through carburetor joints. 	<ul style="list-style-type: none"> • Clean • Clean • Replace (remove gasoline from crankcase) • Replace • Clean • Adjust • Repalce • Replace • Retighten or replace gasket

Poor high speed performance

Ignition System	
Possible Cause	Remedy
<ol style="list-style-type: none"> 1. Spark plug is dirty or plug gap is too narrow. 2. C.D.I. unit is faulty. 3. C.D.I. magneto is faulty. 4. Ignition coil is faulty. 5. Ignition timing is incorrect. 6. Loose wire connection. 	<ul style="list-style-type: none"> • Clean or replace • Replace • Replace • Replace • Adjust • Repair
Compression System	
Possible Cause	Remedy
<ol style="list-style-type: none"> 1. Piston rings are sticking or worn. 2. Cylinder or piston is worn or scratched. 3. Compression leakage through crankcase sealing surfaces or crankshaft side oil seal. 4. Carbon deposits in combustion chamber (Piston, Cylinder head). 5. Power valve malfunctions. 	<ul style="list-style-type: none"> • Replace • Repair or replace • Repair or replace • Decarbonize • Repair or replace
Air/Fuel System	
Possible Cause	Remedy
<ol style="list-style-type: none"> 1. Clogged carburetor jets. 2. Improperly adjusted main jet (High speed) 3. Improperly adjusted jet needle (Medium speed) 4. Incorrect fuel lever 5. Dirty or clogged air cleaner element 6. Clogged fuel tank filler cap or carburetor breather pipe. 7. Clogged fuel petcock or kinked fuel pipe. 8. Deteriorated fuel. 9. Improper oil-gas mixing ratio 10. Cracked or broken exhaust pipe (Leakage of exhaust gases). 	<ul style="list-style-type: none"> • Clean • Adjust • Adjust • Adjust • Clean • Clean • Clean or repair • Replace • Replace • Replace

Overheat

Possible Cause	Remedy
<ol style="list-style-type: none"> 1. Incorrect air-fuel mixture 2. Air leaks through carburetor joint. 3. Incorrect ignition timing 4. Carbon builds up in cylinder head or on piston head. 5. Improper spark plug heat range (too hot) 6. Fuel is deteriorated or oil-gas mixing ratio is incorrect. 7. Coolant of inferior quality. 8. Coolant level is low. 9. Water pump is faulty. 10. Cooling passage is clogged. 11. Radiator is clogged. 	<ul style="list-style-type: none"> • Adjust • Replace or replace • Adjust • Decarbonize • Replace • Replace • Replace with specified type. • Add up to specified line. • Repair or replace. • Clean passage. • Clean radiator.

Low coolant level

Possible Cause	Remedy
<ol style="list-style-type: none"> 1. Radiator is leaky. 2. Hose is damaged or joint is loose. 3. Water pump cover is leaky. 4. Cylinder head gasket is faulty. 	<ul style="list-style-type: none"> • Repair or replace • Replace hose or retighten joint. • Repair or replace • Replace.

Transmission and shifter

Trouble	Possible Cause	Remedy
Gears slip off	<ol style="list-style-type: none"> 1. Gear dogs are worn. 2. Shift forks are bent. (burnt or worn) 3. Shift cam stopper spring is fatigued 	<ul style="list-style-type: none"> • Replace • Replace • Replace
Gear shifts skipping over the next.	<ol style="list-style-type: none"> 1. Shift cam stopper spring is fatigued. 2. Shift forks are bent. (burnt or worn) 	<ul style="list-style-type: none"> • Replace • Replace
Gear does not select	<ol style="list-style-type: none"> 1. Shift cam is worn. (broken) 2. Change shaft is bent. 3. Shift arm spring is broken. 4. Gears are broken. 	<ul style="list-style-type: none"> • Replace • Replace • Replace • Removal (Replace)
Shift pedal does not return	<ol style="list-style-type: none"> 1. Change return spring is broken. 2. Change shaft is bent. 	<ul style="list-style-type: none"> • Replace • Replace

Clutch

Trouble	Possible Cause	Remedy
Clutch slips	<ol style="list-style-type: none"> 1. Friction plate is worn. 2. Clutch plate is worn. 3. Clutch spring is fatigues. 4. Pressure plate is deformed. 5. Clutch play is too small. 6. Clutch adjustment is incorrect. 7. Match marks of clutch boss and pressure plate does not aligned. 	<ul style="list-style-type: none"> • Replace • Replace • Replace • Replace • Adjust • Adjust • Reassemble
Clutch drags	<ol style="list-style-type: none"> 1. Clutch plate is warped. 2. Clutch lock nut is loosen. 3. Friction plate is broken. 4. Clutch play is too much. 5. Oil viscosity is incorrect. 	<ul style="list-style-type: none"> • Replace • Replace • Replace • Adjust • Replace

Chassis

Steering head is loose		
Possible Cause	Remedy	
<ol style="list-style-type: none"> 1. Roller is worn. 2. Steering nut is loose 	<ul style="list-style-type: none"> • Replace • Retighten 	
Wheels have excessive run-out		
Possible Cause	Remedy	
<ol style="list-style-type: none"> 1. Bearing is worn. 2. Rim has dent. 3. Spokes are loose (or broken). 4. Axle nut is loose. 	<ul style="list-style-type: none"> • Replace • Repair or replace • Retighten or replace • Retighten 	
Brakes		
Trouble	Possible Cause	Remedy
Faulty	<ol style="list-style-type: none"> 1. Brake pad are worn. 2. Brake is improperly adjusted. 3. Brake pad is greasy. 	<ul style="list-style-type: none"> • Replace • Adjust • Degrease or replace
Not return smoothly	<ol style="list-style-type: none"> 1. Return spring is broken. 2. Brake pedal axle is starved for grease. 3. Brake fluid leaking 	<ul style="list-style-type: none"> • Replace • Grease • Replace damaged parts and bleed air
Frame and Swingarm		
Possible Cause	Remedy	
<ol style="list-style-type: none"> 1. Frame is cracked. 2. Swingarm is bend. 3. Swingarm is cracked. 4. Bushing is worn. 5. Bushing lacks oil. 	<ul style="list-style-type: none"> • Weld, reinforce or replace • Repair or replace • Replace • Replace • Lubricate 	

SPECIFICATIONS

1. GENERAL SPECIFICATIONS

Item	Model	YTZ250N
Model Code Number		38W
Vehicle identification number		JY338W00*FC000101
Engine Starting Number		38W-000101
Dimensions:		
Overall Length		1,920 mm (75.6 in)
Overall Width		1,090 mm (42.9 in)
Overall Height		1,060 mm (41.7 in)
Seat Height		750 mm (29.5 in)
Wheelbase		1,325 mm (52.7 in)
Minimum Ground Clearance		245 mm (9.64 in)
Basic Weight:		
With Oil and Full fuel Tank		143 kg (315.3 lb)
Minimum Turning Radius:		245 mm (9.64 in)
Engine:		
Engine Type		Liquid, cooled 2-stroke, gasoline, torque induction
Cylinder Arrangement		Single cylinder, forward inclined
Displacement		246 cm ³
Bore × Stroke		68 × 68 mm (2,677 × 2,677 in)
Compression Ratio		7.7 : 1
Starting System		Kick starter
Lubrication System		Premix (24:1) (Yamalube R) Premix (20:1) (Castrol R30) (Castrol A545) (Castrol A747)
Oil Type or Grade (2-Cycle):		
Transmission Oil		Yamalube 4-cycle oil or SAE 10W30 type SE motor oil or GL gear oil
Periodic Oil Change		1.00 L (0.88 Imp qt, 1.05 US qt)
Total Amount		1.05 L (0.92 Imp qt, 1.10 US qt)
Radiator Capacity (Including All Routes)		1.0 L (0.88 Imp qt, 1.06 US qt)
Air Filter		Wet type element
Fuel:		
Type		Premix Premium gasoline
Tank Capacity		10.0 L (2.6 Imp gal, 2.2 US gal)
Carburetor:		
Type/Manufacturer		VM32SS/MIKUNI
Spark plug:		
Type/Manufacturer		B8ES/NGK
Gap		0.7 ~ 0.8 mm (0.028 ~ 0.031 in)
Clutch Type		Wet, multiple-disk

Item	Model YTZ250N
Transmission:	
Primary Reduction System	Spar gear
Primary Reduction Ratio	63/24 (2.625)
Secondary Reduction System	Chain drive
Secondary Reduction Ratio	44/73 (3.384)
Transmission Type	Constant mesh, 5-speed
Operation	Left foot operation
Gear Ratio 1st	31/13 (2.384)
2nd	28/16 (1.750)
3rd	24/17 (1.411)
4th	24/21 (1.142)
5th	22/23 (0.956)

Item	Model	YTZ250N
Chassis: Frame Type Caster Angle Trail		Tubular, Semi double cradle 22°30' 35 mm (1.38 in)
Tire: Type Size (F) Size (R)		Tubeless 25 × 8 – 12 22 × 11 – 8 (2 pcs)
Tire Pressure (Cold tier): Front Rear Standard tire circumference Minimum tire circumference	Front: Rear: Front: Rear:	22.6 kPa (0.23 kg/cm ² , 3.3 psi) 16.7 kPa (0.17 kg/cm ² , 2.41 psi) 1,923 mm (75.7 in) 1,745 mm (68.7 in) 1,917 mm (75.5 in) 1,740 mm (68.5 in)
Brake: Front Brake Type Operation Rear Brake Type Operation		Single disc Right hand operation Single disc brake Right foot operation
Suspension: Front Suspension		Telescopic fork
Shock Absorber: Front Rear		Coil spring, Air-Oil damper Coil spring, Gas-Oil damper
Wheel Travel: Front Wheel Travel Rear Wheel Travel		230 mm (9.1 in) 220 mm (8.7 in)
Electrical: Ignition System Generator System		C.D.I. Magneto Flywheel magneto
Headlight Type:		Bulb Type
Bulb Wattage × Quantity: Headlight Taillight Pilot light		30 W/30 W × 2 3.8 W × 1 3.4 × 1

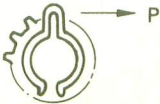
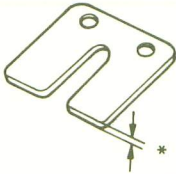
Item	Model	YTZ250N
Clutch: Friction Plate Thickness/Quantity Wear Limit Clutch Plate Thickness/Quantity Warp Limit Clutch Spring Free Length/Quantity Clutch Spring Minimum Length Clutch Housing Thrust Clearance Clutch Housing Radial Clearance Clutch Release Method Push Rod Bending Limit		3.0 mm (0.12 in) × 7 <2.7 mm (0.11 in) > 1.6 mm (0.063 in) × 6 <0.05 mm (0.002 in) > <34.9 mm (1.374 in) × 6 <33.9 mm (1.335 in) > 0.17 ~ 0.23 mm (0.067 ~ 0.0090 in) 0.03 ~ 0.55 mm (0.0012 ~ 0.0217 in) Inner push, cam axle <0.2 mm (0.008 in) >
Transmission: Main Axle Deflection Limit Drive Axle Deflection Limit		<0.01 mm (0.0004 in) > <0.01 mm (0.0004 in) >
Shifter: Shifting Type Guide Bar Bending Limit		Guide bar <0.05 mm (0.0020 in) >
Kick Starter Type: Kick Clip Friction Force		Kick and mesh type P = 0.8 ~ 1.2 kg (1.76 ~ 2.65 lb)
Air Filter Oil Grade (Oiled Filter)		Foam-air-filter oil or SAE10W30SE
Carburetor: Type/Manufacturer I.D. Mark Main Jet (M.J.) Main Air Jet (M.A.J.) Jet Needle-clip Position (J.N.) Needle Jet (N.J.) Cutaway (C.A.) Pilot Jet (P.J.) Pilot Air Screw (P.A.S.) Valve Seat Size (V.S.) Starter Jet (G.S.) Float Height (F.H.) Engine Idle Speed		VM32SS/MIKUNI 38W00 # 470 φ2.5 6H3-3 P-2 2-0 # 45 1.0 turn out φ3.3 φ1.3 31.3 ± 1.0 mm (1.23 ± 0.04 in) 1500 ± 50 rpm
Reed Valve: Thickness* Valve Stopper Height Valve Bending Limit		0.20 mm (0.008 in) 12 ± 0.2 mm (0.472 ± 0.008 in) 0.6 mm (0.022 in)
Fuel Pump: Type/Manufacturer Model		Mechanical Type/MIKUNI DF52-75

Item	Model	YTZ250N
Cooling: Radiator Core size Width Height Thickness Radiator Cap Opening Pressure Coolant Capacity (Total) Water Pump Type Oil Seal Type Recution Ratio		110 mm (4.33 in) 200 mm (7.9 in) 32 mm (1.26 in) 93.1 ~ 12.3 kPa (0.95 ~ 1.25 kg/cm ² , 13.5 ~ 17.8 psi) 1.0 L (0.88 Imp qt, 1.06 US qt) Single-Suction Centrifugal Pump FLJ-7-10-31-13.5 18/24 (0.75)

Tightening Torque	Thread Size	Nm	m·kg	ft·lb
Spark plug	M14×1.25	25	2.5	18
Cylinder head -Nut	M 8×1.25	25	2.5	18
-Stud	M 8	13	1.3	9.4
Cylinder drain bolt	M 6×1.0	10	1.0	7
Cylinder -Nut	M10×1.25	35	3.5	25
-Stud	M10×1.25	13	1.3	10
Housing cover -Panhead screw	M 6×1.0	10	1.0	7
-Bolt	M 6×1.0	10	1.0	7
Intake manifold	M 6×1.0	12	1.2	9
Crankcase	M 6×1.0	12	1.2	9
Crankcase cover	M 6×1.0	10	1.0	7
Crankcase cover 1	M 6×1.0	10	1.0	7
Bearing cover plate	M 6×1.0	10	1.0	7
Holder	M 8×1.25	16	1.6	12
Plate	M 6×1.0	10	1.0	7
Oil drain bolt	M12×1.5	20	2.0	14
Kickstarter lever	M 8×1.0	20	2.0	14
Primary drive gear	M18×1.0	115	11.5	85
Clutch	M20×1.0	75	7.5	54
Push rod 1	M 6×1.0	10	1.0	7
Clutch spring	M 6×1.0	10	1.0	7
Drive sprocket	M20×1.0	75	7.5	54
Shift pedal	M 6×1.0	10	1.0	7
Stopper lever	M 6×1.0	15	1.5	11
Magneto rotor	M12×1.25	85	8.5	61
Magneto backing plate	M 6×1.0	8	0.8	6

Item	Model	YTZ250N
Wheel: Front Wheel Type Rear Wheel Type Front Rim Size/Material Rear Rim Size/Material Rim Runout Limit Vertical Lateral		Disc Wheel Disc Wheel 6.5 × 12/Aluminum 8.25 × 8/Aluminum <2.0 mm (0.08 in) > <2.0 mm (0.08 in) >
Drive Chain: Type/Manufacturer Number of Links Chain Free Play		520 V/DAIDO 98 links 30 ~ 35 mm ((1.18 ~ 1.38 in))
Disc Brake: Type Front & Rear Outside Dia × Thickness Pad Thickness < Limit > Inner Outer Brake Fluid Type Master Cylinder Inside Dia. Caliper Cylinder Inside Dia.		Single disc 203 × 4 mm (8 × 0.16 in) 8.0 mm (0.31 in) < 0.8 mm (0.03 in) > 8.0 mm (0.31 in) < 0.8 mm (0.8 mm (0.03 in) > DOT #3 12.7 mm (0.49 in) 34.93 mm (1.37 in)
Brake lever & Brake Pedal: Brake Lever Free Play Brake Pedal Free Play		4.0 ~ 8.0 mm (0.16 ~ 0.31 in) at lever end 6 mm (0.24 in)
Clutch Lever: Clutch Lever Free Play		10 ~ 15 mm (0.39 ~ 0.59 in) at lever end

Tightening torque:	Thread size	Nm	m·kg	ft·lb	Remarks
Front axle shaft	M14 × 1.5	58	5.8	42	
Under bracket & inner fork tube	M8 × 1.25	20	2.0	14	
Front axle & Outer fork tube	M8 × 1.25	20	2.0	14	
Front wheel panel & Front hub	M8 × 1.25	28	2.8	20	
Rear wheel panel & Wheel shaft collar	M10 × 1.25	45	4.5	32	
Steering crown & inner fork tube	M10 × 1.25	40	4.0	29	
Steering stem	M22 × 1.0	85	8.5	61	
Steering shaft ring nut	M25 × 1.0	45	4.5	32	
Handlebar upper holder	M8 × 1.25	23	2.3	17	
Engine front bracket & Engine	M8 × 1.25	30	3.0	22	
Engine front bracket & Frame	M8 × 1.25	30	3.0	22	
Upper engine bracket & Engine	M8 × 1.25	55	5.5	40	
Upper engine bracket & Frame	M8 × 1.25	30	3.0	22	
Lower engine mounting bolt	M8 × 1.25	30	3.0	22	
Frame & Rear shock absorber	M10 × 1.25	32	3.2	23	
Relay arm & Rear shock absorber	M10 × 1.25	32	3.2	23	
Relay arm & Frame	M10 × 1.25	48	4.8	35	
Swing arm & Connecting rod	M10 × 1.25	48	4.8	35	
Relay arm & Connecting rod	M10 × 1.25	32	3.2	23	
Disc brake (Front & Rear)	M8 × 1.25	28	2.8	20	
Brake carliper (Front & Rear)	M10 × 1.25	35	3.5	25	
Brake hose union bolt	M10 × 1.25	27	2.7	19	
Engine rear & Frame (Pivot shaft)	M16 × 1.50	85	8.5	61	
Rear axle shaft & Wheel shaft collar	M14 × 1.50	100	10.0	72	
Rear axle shaft ring nut	M33 × 1.50	133	13.3	98	
Driven sprocket	M8 × 1.25	30	3.0	22	Use lock washer
Rear hub & Swing arm (Upper)	M10 × 1.25	50	5.0	36	
Rear hub & Swing arm (Lower)	M12 × 1.25	80	8.0	58	
Footrest bracket & Frame	M10 × 1.25	55	5.5	40	

C. Electrical

Item	Model	YTZ250N
Voltage		12 V
Ignition System: Ignition timing (B.T.D.C.) Advanced Timing (B.T.D.C.) Advancer Type		<p>4° at 300 r/min 16° at 2,000 r/min</p> <p>Electrical</p>
C.D.I.: Magneto-Model/Manufacturer Pickup Coil Resistance (Color) Charging Coil Resistance (Color) C.D.I. Unit-Model/Manufacturer		<p>F3T2547/MITSUBISHI 10.7Ω ± 10% at 20°C (68°F) (W/R-B) 315Ω ± 10% at 20°C (68°F) (Br-B) F8T07072/MITSUBISHI</p>
Ignition Coil: Model/Manufacturer Minimum Spark Gap Primary Winding Resistance Secondary Winding Resistance		<p>F6T51072/MITSUBISHI 6 mm (0.24 in) 0.79Ω ± 15% at 20°C (68°F) 5.9KΩ ± 15% at 20°C (68°F)</p>
Charging System/Type		Flywheel magneto
F.W. Magneto: Lighting Voltage Lighting Coil Resistance (Color)		<p>8.5 V or more at 1,500 r/min 16 V or less at 8,000 r/min 0.58Ω ± 10% at 20°C (68°F) (Y/R-B)</p>
Voltage Regulator: Model/Manufacturer Type No Load regulated Voltage		<p>S3516B/TOSHIBA TRIZ-50/HITACHI Short circuit type 13.5 ~ 14.1 V</p>
Pilot light checker: Model/Manufacturer		EUP-F2B1M220B/MATSUSHITA

GENERAL TORQUE SPECIFICATIONS

This chart specifies torque for standard fasteners with standard I.S.O. pitch threads. Torque specifications for special components or assemblies are included in the applicable sections of this book. To avoid warpage, tighten multi-fastener assemblies in a crisscross fashion, in progressive stages, until full torque is reached. Unless otherwise specified, torque specifications call for clean, dry threads. Components should be at room temperature.

A (Nut)	B (Bolt)	General torque specifications		
		Nm	m·kg	ft·lb
10 mm	6 mm	6	0.6	4.3
12 mm	8 mm	15	1.5	11
14 mm	10 mm	30	3.0	22
17 mm	12 mm	55	5.5	40
19 mm	14 mm	85	8.5	61
22 mm	16 mm	130	13.0	94

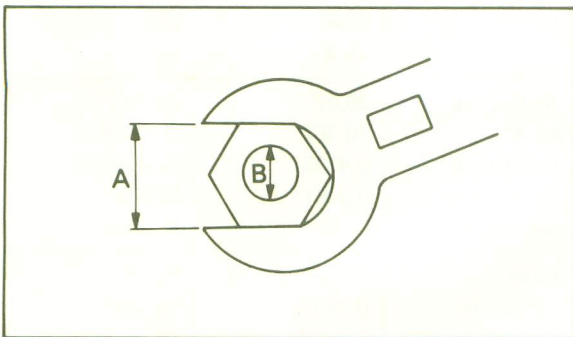

A: Distance across flats

B: Outside thread diameter

DEFINITION OF UNITS

Unit	Read	Definition	Measure
mm	millimeter	10^{-3} meter	Length
cm	centimeter	10^{-2} meter	Length
kg	kilogram	10^3 gram	Weight
N	Newton	$1 \text{ kg} \times \text{m}/\text{sec}^2$	Force
Nm	Newton meter	$\text{N} \times \text{m}$	Torque
m·kg	Meter kilogram	$\text{m} \times \text{kg}$	Torque
Pa	Pascal	N/m^2	Pressure
N/mm	Newton per millimeter	N/mm	Spring rate
L	Liter	—	Volume
cm^3	Cubic centimeter	—	or Capacity
r/min	Rotation per minute	—	Engine Speed

CONVERSION TABLES

Metric to inch system		
Known	Multiplier	Result
m·kg	7.233	ft·lb
m·kg	86.80	in·lb
cm·kg	0.0723	ft·lb
cm·kg	0.8680	in·lb
kg	2.205	lb
g	0.03527	oz
km/lit	2.352	mpg
km/hr	0.6214	mph
km	0.6214	mi
m	3.281	ft
m	1.094	yd
cm	0.3937	in
mm	0.03937	in
cc (cm ³)	0.03382	oz (US liq)
cc (cm ³)	0.06102	cu in
lit (liter)	2.1134	pt (US liq)
lit (liter)	1.057	qt (US liq)
lit (liter)	0.2642	gal (US liq)
kg/mm	56.007	lb/in
kg/cm ²	14.2234	psi (lb/in ²)
Centigrade (°C)	9/5 (°C) + 32	Fahrenheit (°F)

Inch to metric system		
Known	Multiplier	Result
ft·lb	0.13826	m·kg
in·lb	0.01152	m·kg
ft·lb	13.831	cm·kg
in·lb	1.1521	cm·kg
lb	0.4535	kg
oz	28.352	g
mpg	0.4252	km/lit
mph	1.609	km/hr
	1.609mi	km
ft	0.3048	m
yd	0.9141	m
in	2.54	cm
in	25.4	mm
oz (US liq)	29.57	cc (cm ³)
cu in	16.387	cc (cm ³)
pt (US liq)	0.4732	lit (liter)
qt (US liq)	0.9461	lit (liter)
gal (US liq)	3.785	lit (liter)
lb/in	0.017855	kg/mm
psi (lb/in ²)	0.07031	kg/cm ²
Fahrenheit (°C)	5/9 (°F) - 32	Centigrade (°F)

CABLE ROUTING

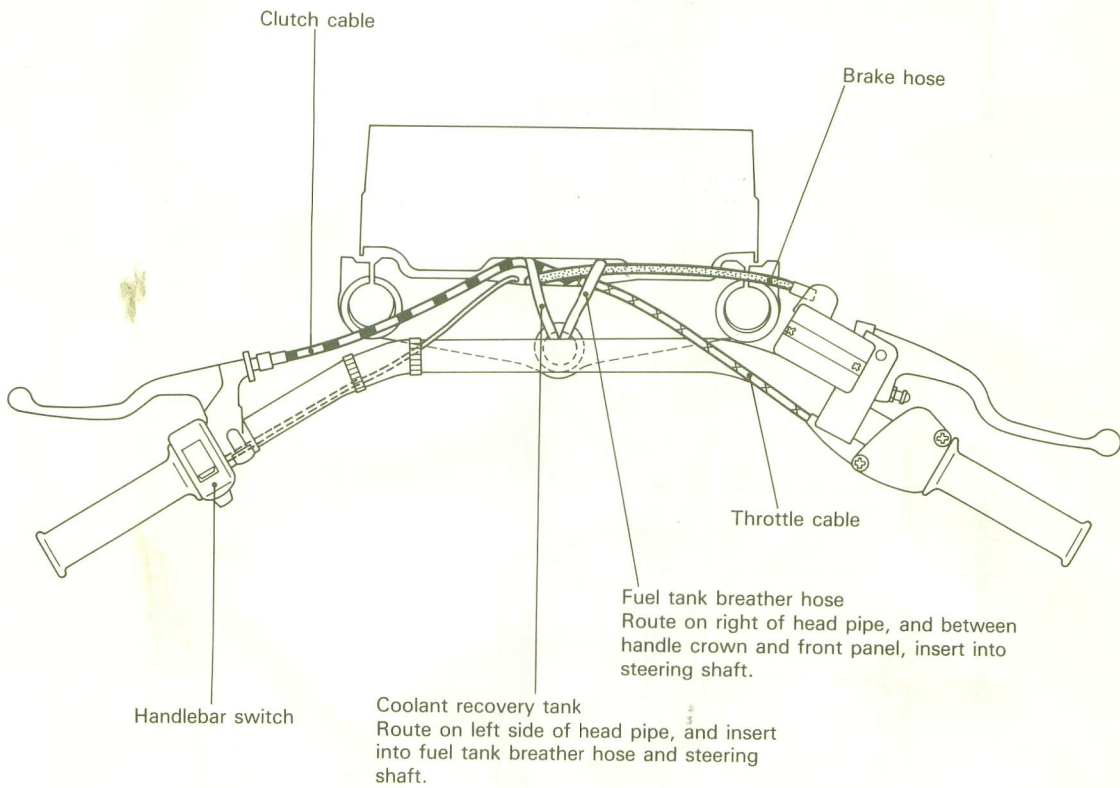

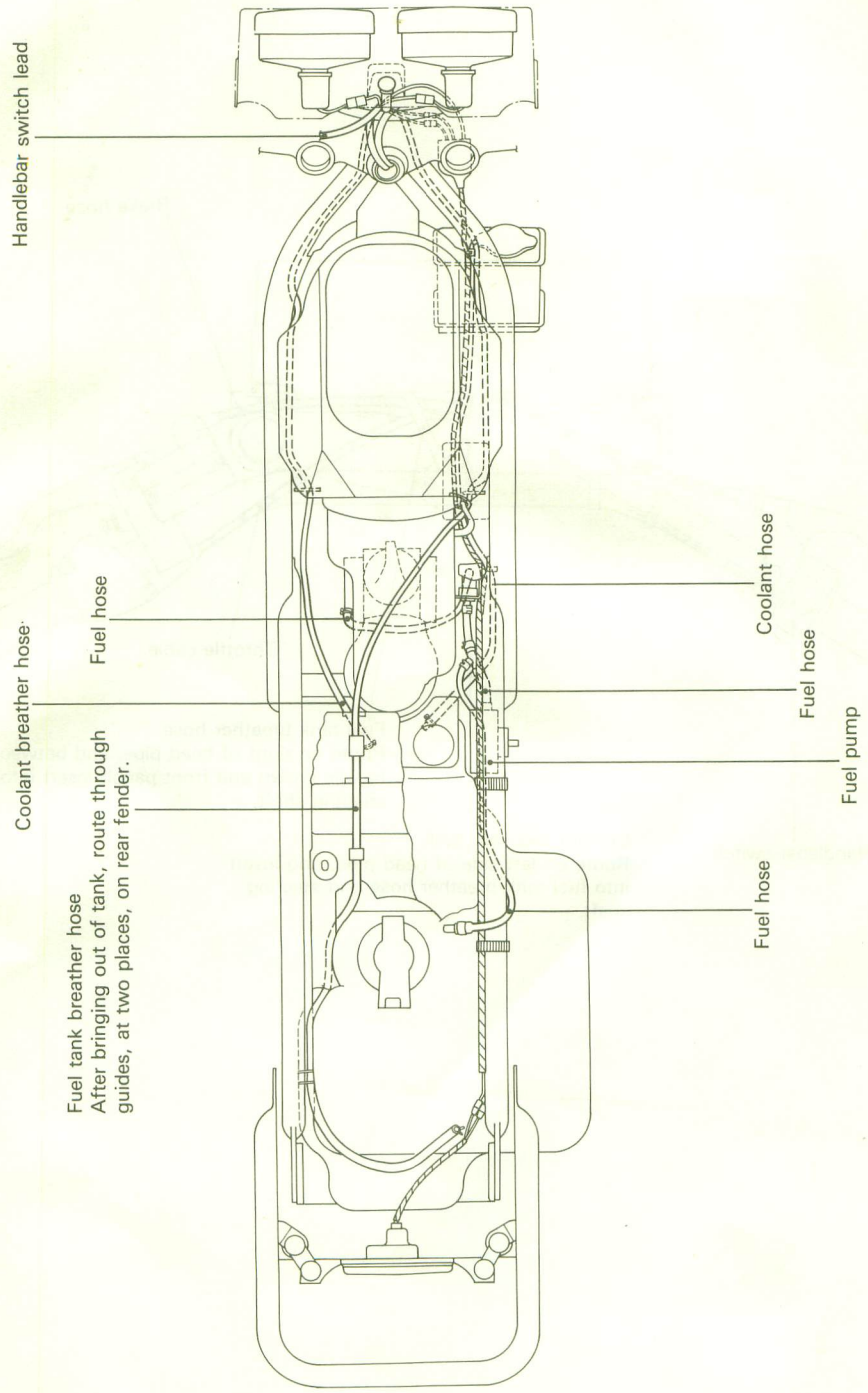

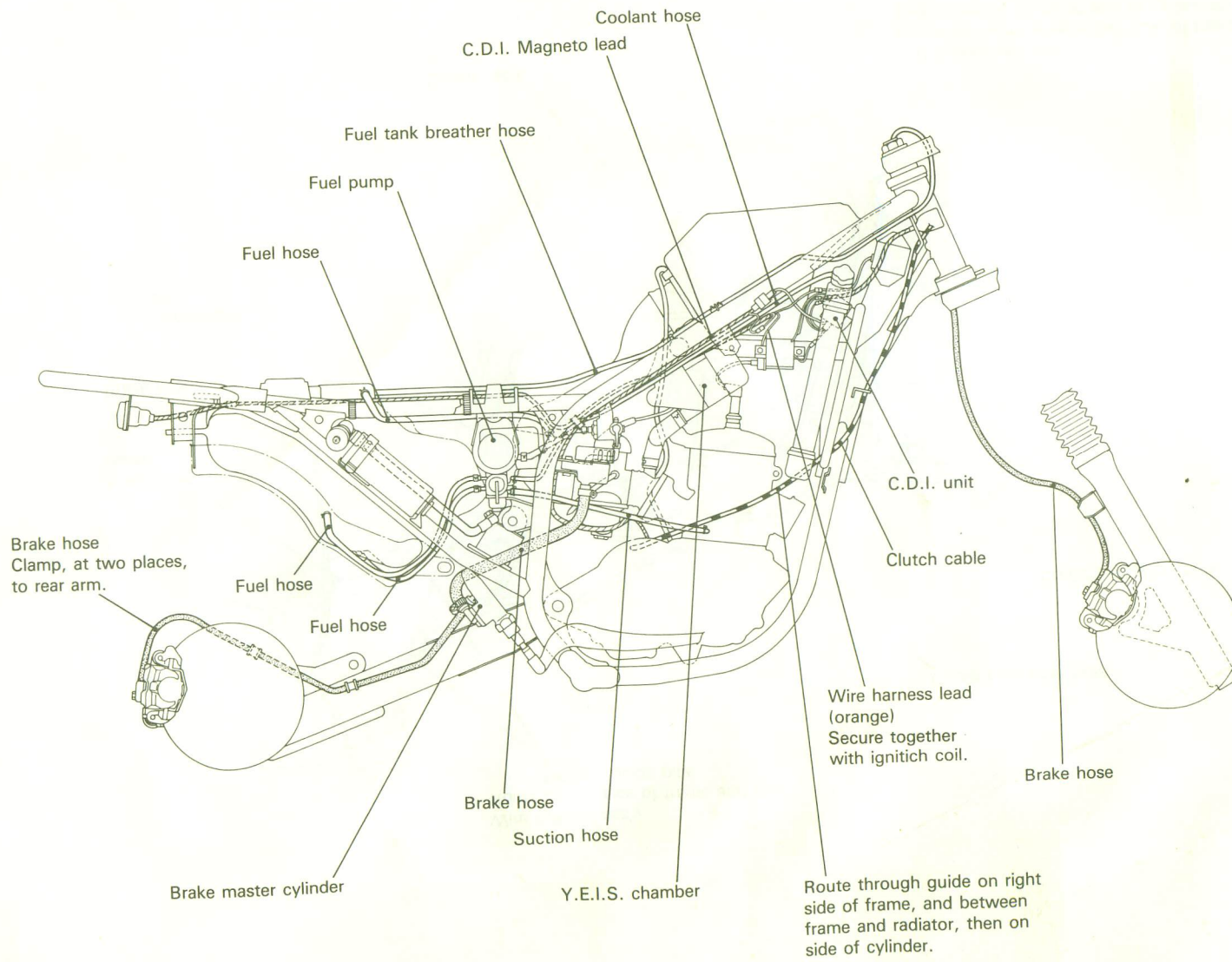

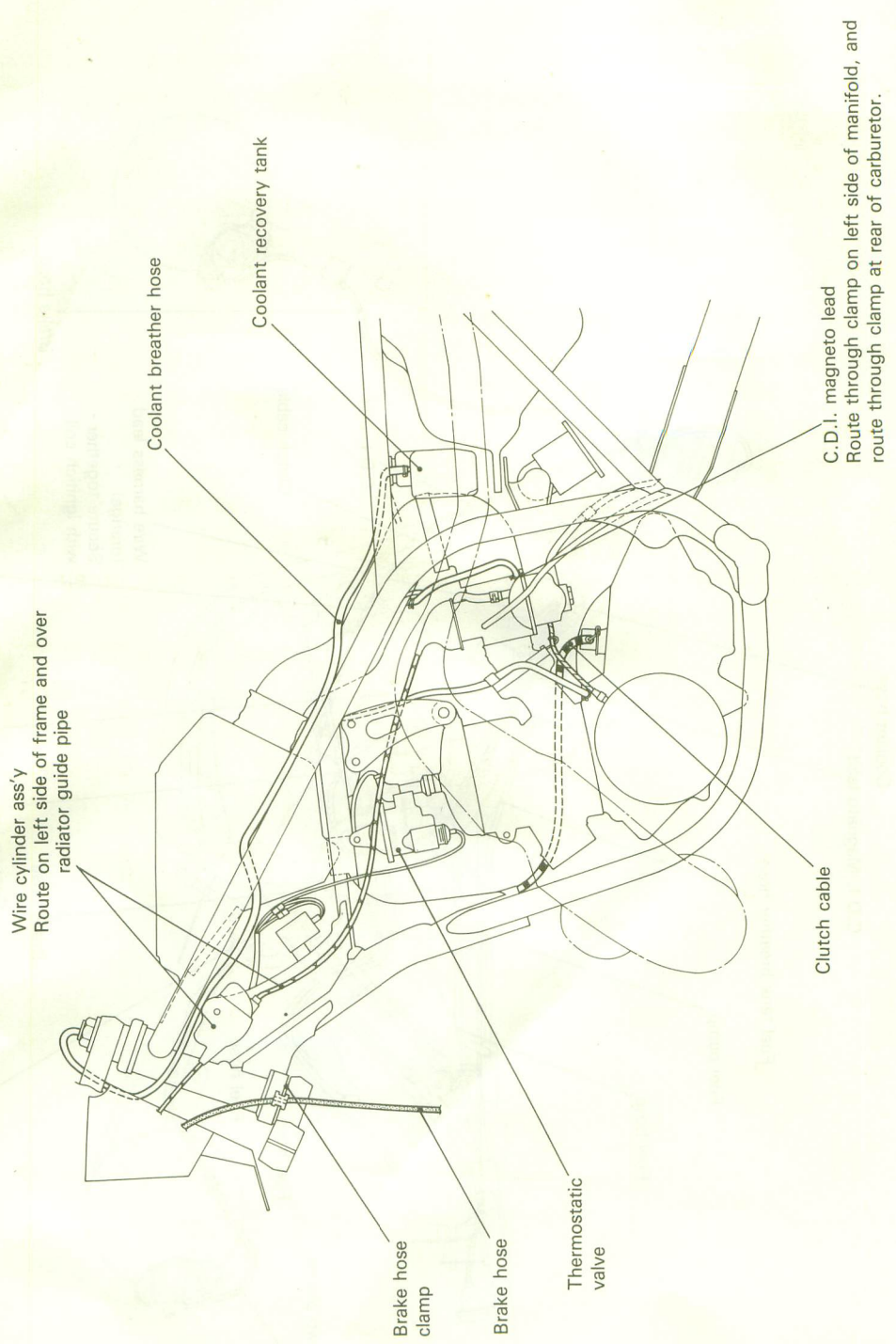

WARRANTY INFORMATION

Please refer to your copy of the YAMAHA LIMITED WARRANTY* for details of the warranty offered on your new Yamaha.

The YAMAHA LIMITED WARRANTY contains the warranty policy, an explanation of the warranty, and other important information. Becoming familiar with these policies will help you make the best use of Yamaha's warranty programs.

There are *certain* requirements which you must meet in order to qualify for warranty coverage. FIRST, your new Yamaha must be operated and maintained properly, as explained in this manual. If you have any questions about procedure in this manual, please consult a dealer.

ABUSE AND NEGLECTED MAINTENANCE MAY LEAD TO MECHANICAL FAILURES WHICH CANNOT BE COVERED UNDER WARRANTY.

SECOND, IF ANY PROBLEMS OCCUR WHICH YOU FEEL SHOULD BE COVERED UNDER WARRANTY, NOTIFY YOUR DEALER IMMEDIATELY. Don't delay, as small problems left unrepaired can become large problems which may not be covered under warranty.

We recommend that the YAMAHA LIMITED WARRANTY be used as a folder in which you may keep your registration and other important documents related to your new Yamaha.

* The YAMAHA LIMITED WARRANTY is to be supplied by a Yamaha dealer at the time of purchase. If you did not receive one, or have lost yours, you may obtain extra copies upon request from your Yamaha dealer or by writing to:

YAMAHA MOTOR CORPORATION U.S.A.

6555 Katella Avenue

P.O. Box 6555

Cypress, California 90630

Attn: Warranty Department

